

fill level

water level

pressure

temperature

flow

registration

visualization

signal
converter

sensor
technic

UPS



Technical Information

Vibrocont VFS40/41

Level limit switch

Robust vibration limit switch for bulk solids,
also for dust incensive hazard areas



Application

Vibrocont VFS40/41 is a robust level limit switch for silos with fine-grained or coarse-grained, non-fluidised bulk solids. The various designs means the device has a wide range of applications. Certificates are also available for use in dust incensive hazard areas.

VFS40/41 compact design (250 mm) as vibrating rod for installation in any direction

VFS40/41 vibrating rod with extension pipe (500 mm/1000 mm/1500 mm/20 in/40 in/60 in) for installation in any direction

Typical applications: cereals, coffee beans, sugar, animal feed, rice, detergents, dye powder, chalk, gypsum, cement, sand, plastic granules

Your benefits

- No calibration: easy commissioning (plug and play)
- Insensitive to build-up: maintenance-free operation
- No mechanically moving parts: no wear, long operating life
- Sensor material 316L: hardly any abrasion even with building materials
- F16 plastic housing with cover with sight glass: switch status visible from outside
- F18 aluminium housing also available
- Insensitive to external vibration and flow noises
- Also available with explosion protection ATEX II 1/3 D, FM or CSA approval

Table of contents

Function and system design.....	3	Mechanical construction	9
Measuring principle	3	Design, dimensions	9
Measuring system	3	Weight	10
		Material	10
Cable specifications	4	Human interface	10
Cable entries	4	Display elements	10
Input	4	Operating elements of electronic inserts FEM22 and FEM24 ...	11
Measured variable	4	Sediment detection	11
Measuring range (application)	4	Certificates and approvals	12
Input signal	4	CE mark, declaration of conformity	12
Measuring frequency	4	Ex approval	12
Output	4	Type of protection	12
Galvanic isolation	4	Other standards and guidelines	12
Switch behaviour	4	Ordering information.....	13
Power-on behaviour	4	Vibrocont VFS 40	13
Fail-safe mode	4	Vibrocont VFS41.....	14
Switching delay	4	Accessories	15
Ex specifications	4	Sliding sleeve	15
FEM22 electronic insert (DC PNP)	5	Spare parts	15
Power supply	5	Supplementar documentation	16
Electrical connection	5	Operating Instructions.....	16
Output signal	5	Certificates	16
Signal on alarm	5		
Connectable load	5		
FEM24 electronic insert (AC/DC with relay output) ..	6		
Power supply	6		
Electrical connection	6		
Output signal	6		
Signal on alarm	6		
Connectable load	6		
Operating conditions	7		
Installation instructions	7		
Environment	7		
Ambient temperature range	7		
Storage temperature	7		
Climate class	7		
Degree of protection	7		
Vibration resistance	7		
Electrical safety	7		
Electromagnetic compatibility	7		
Process	8		
Environment	8		
Thermal shock resistance	8		
Limiting medium pressure range	8		
State of aggregation	8		
Grain size	8		
Bulk density	8		
Lateral load	8		

Function and system design

Measuring principle

A piezoelectric drive excites the vibrating rod of Vibrocont VFS40, VFS41 to its resonance frequency. If medium covers the vibrating rod, the rod's vibrating amplitude changes (the vibration is damped). Soliphant's electronics compare the actual amplitude with a target value and indicates whether the vibrating rod is vibrating freely or whether it is covered by medium.

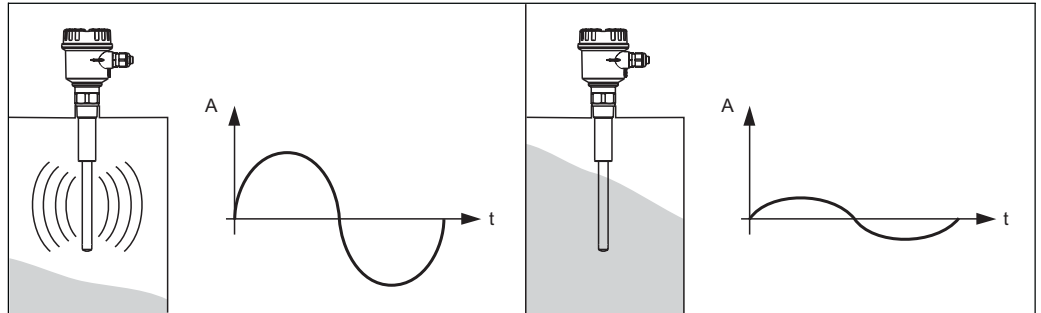

A = amplitude

Measuring system

Soliphant T is a compact electronic switch.

Thus, the entire measuring system only consists of:

- Vibrocont VFS40 or VFS41 with FEM22 or FEM24 electronic insert
- a supply point and
- the connected control systems, switching units, signalling systems (e.g. lamps, horns, PCS, PLC, etc.)

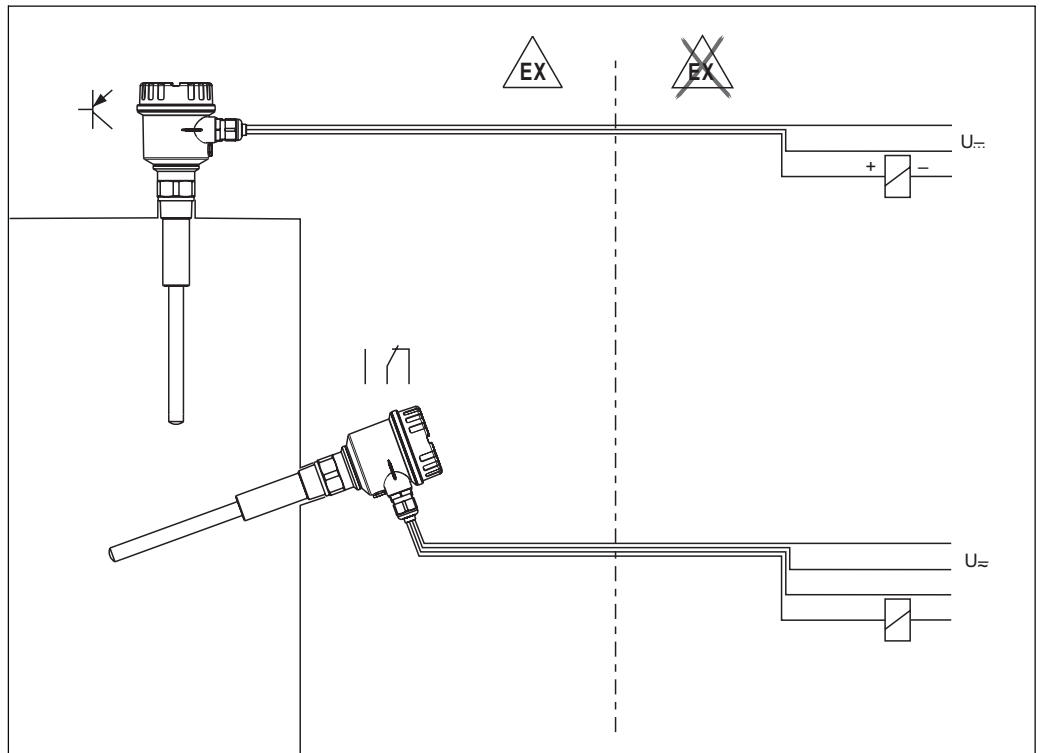

Cable specifications

Use a shielded cable in the event of strong electromagnetic radiation.

Immunity to temperature change of connecting cable
The connecting cables must withstand the ambient temperature +15 K.

Cable entries	M20x1.5 (cable gland); NPT ; G
---------------	--------------------------------

Input

Measured variable	Level (according to the mounting location and the overall length)
-------------------	---

Measuring range (application)	The measuring range depends on the mounting location of Vibrocont and the length of the pipe extension selected. The pipe extension is available in the following lengths: 500 mm, 1000 mm, 1500 mm, 20 in, 40 in, 60 in.
-------------------------------	---

Input signal	Probes covered => small amplitude Probe not covered => large amplitude
--------------	---

Measuring frequency	700...800 Hz
---------------------	--------------

Output

Galvanic isolation	FEM22: Between sensor and power supply FEM24: Between sensor, power supply and load
--------------------	--

Switch behaviour	Binary
------------------	--------

Power-on behaviour	When switching on the power supply the output is set to "signal on alarm". After a maximum of 3 s it switches to the correct output signal.
--------------------	--

Fail-safe mode	Minimum/maximum quiescent current safety can be switched at electronic insert Max. = maximum safety: When the vibrating rod is covered, the output switches in the direction of the signal on alarm Used for overfill protection for example Min. = minimum safety: When the vibrating rod becomes exposed, the output switches in the direction of the signal on alarm Used for empty running protection for example
----------------	---

Switching delay	0.5 s when the sensor is covered 1 s when the sensor is exposed
-----------------	--

Ex specifications	FEM22, FEM24: – Explosion protection for explosive dust-air mixtures: Dust-Ex, DIP
-------------------	--

VFS40 electronic insert (DC PNP)

Power suppl	DC voltage 10 V...45 V Ripple max. 5 V, 0...400 Hz Current consumption max. 15 mA Power consumption max. 0.68 W Reverse polarity protection Separation voltage: 2.2 kV VFS40 overvoltage protection: overvoltage category III
-------------	---

Electrical connection	Three-wire direct current connection Preferred in conjunction with programmable logic controllers (PLC), DI modules as per EN 61131-2. Positive signal at electronics switch output (PNP); Output blocked at level limit.
-----------------------	---

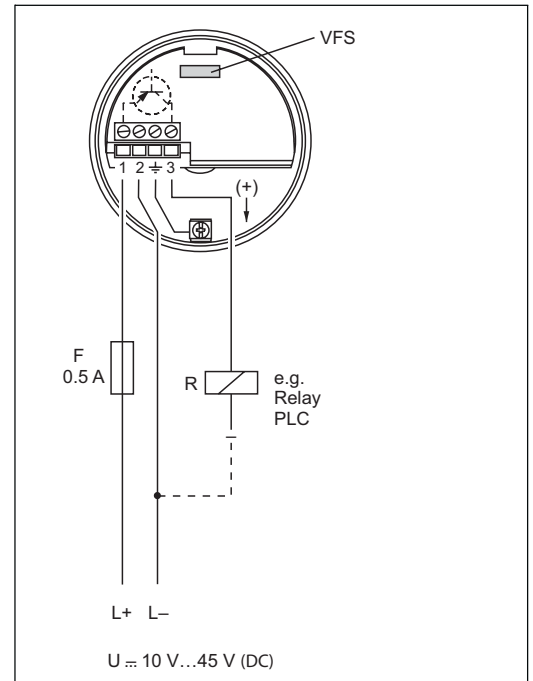

Output signal









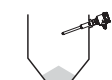

IL = Load current (switched through)

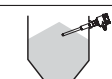
< 100 µA = Residual current (blocked)

 = Lit

 = Not lit

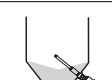
L00-FTL2xxxx-07-05-xx-xx-000

Fail-safe mode	Level	Output signal	LEDs	
			green	ellow
Max.		$L+ \xrightarrow{I_L} +$ 1 → 3		
		$1 \xrightarrow{< 100 \mu A} 3$		
Min.		$L+ \xrightarrow{I_L} +$ 1 → 3		
		$1 \xrightarrow{< 100 \mu A} 3$		

Signal on alarm	Output signal on power failure or in the event of device failure: < 100 µA
-----------------	--

Connectable load	<ul style="list-style-type: none"> • Load switched via transistor and separate PNP connection • Load current: max. 45 V (cyclical overload and short-circuit protection), continuous max. 350 mA • Residual current: < 100 µA (for blocked transistor) • Capacitive load: max. 0.5 µF for 45 V, max. 1.0 µF for 24 V • Residual voltage: < 3 V (for transistor switched through)
------------------	---

FEM24 electronic insert (AC/DC with relay output)

Power supply
 Alternating voltage 19 V...253 V, 50/60 Hz or DC voltage 19 V...55 V
 Power consumption max. 1.3 W
 Reverse polarity protection
 Separation voltage: 2.2 kV
 FEM24 overvoltage protection: overvoltage category III

Electrical connection Universal current connection with relay output

Power supply:
 Please note the different voltage ranges for AC and DC.

Output:
 When connecting a device with high inductance, provide a spark arrester to protect the relay contact.
 A fine-wire fuse (depending on the load connected) protects the relay contact in the event of a short-circuit.

Both relay contacts switch simultaneously. DPDT (double pole double throw)

* When jumpered, the relay output works with NPN logic.

** See below "Connectable load"

! **Note!**
 Please note the different voltage ranges for direct and alternating current.

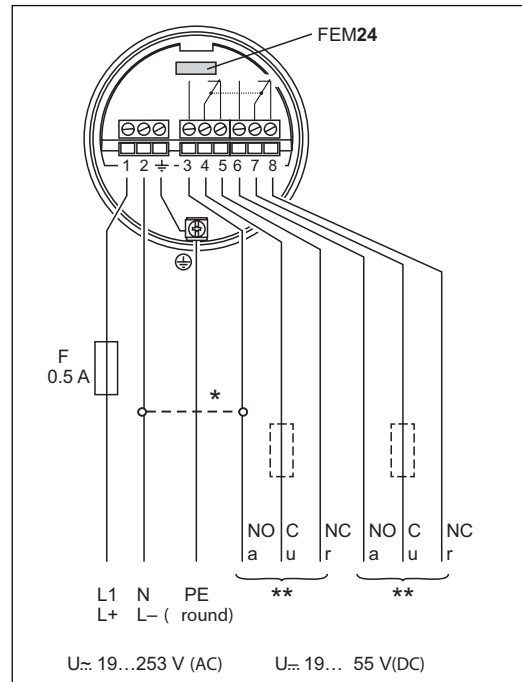

Output signal

= Relay energised
 = Relay de-energised
 = Lit
 = Not lit
L00-FTL2xxxx-07-05-
 xxx-001

Fail-safe mode	Level	Output signal	LEDs	
			green	ellow
Max.				
Min.				

Signal on alarm Output signal in event of power failure: relay de-energised

Connectable load

- Loads switched via 2 floating change-over contacts.
- I~ max. 6 A, U~ max. 253 V; P~ max. 1500 VA, cos φ = 1, P~ max. 750 VA, cos φ > 0.7;
- I- max. 6 A to 30 V, I- max. 0.2 A to 125 V.
- The following applies when connecting a functional extra-low voltage circuit with double insulation as per IEC 1010: Sum of voltages of relay output and power supply max. 300 V

Operating conditions

Installation instructions

Mounting location

e.g. storage or buffer container

Orientation

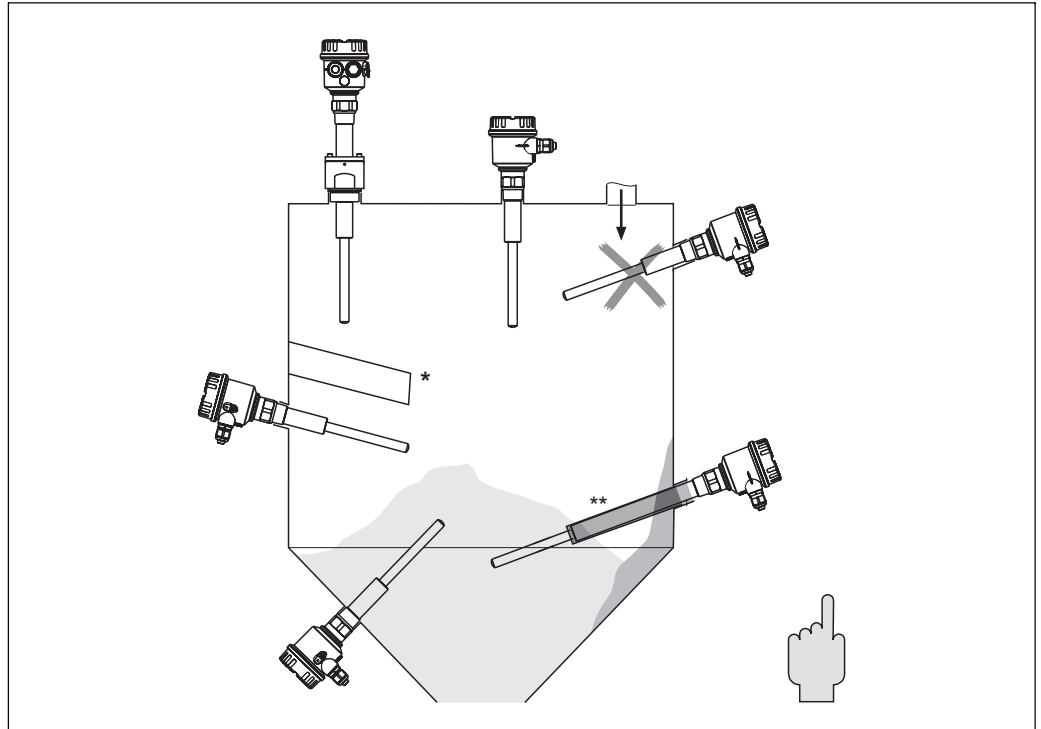

Horizontal installation/vertical installation

* With protective cover (to be provided by customer)

** With protecting tube (to be provided by customer)

Environment

Ambient temperature range	-40...70 °C
Storage temperature	-40...85 °C
Climate class	Climatic protection as per DIN IEC 68 Part 2-38, Fig. 2a
Degree of protection	IP66/IP67, NEMA4X
Vibration resistance	DIN 60068-2-27 / IEC 68-2-27: shock 30 g; vibration 0.01 g ² /Hz
Electrical safety	IEC 61010, CSA 1010.1-92, FM3600
Electromagnetic compatibility	Interference emission to EN 61326, Electrical Equipment Class B Interference immunity to EN 61326, Annex A (Industrial)

Process

Environment

Permitted ambient temperature T_a at housing depending on the medium temperature T_p in the container:

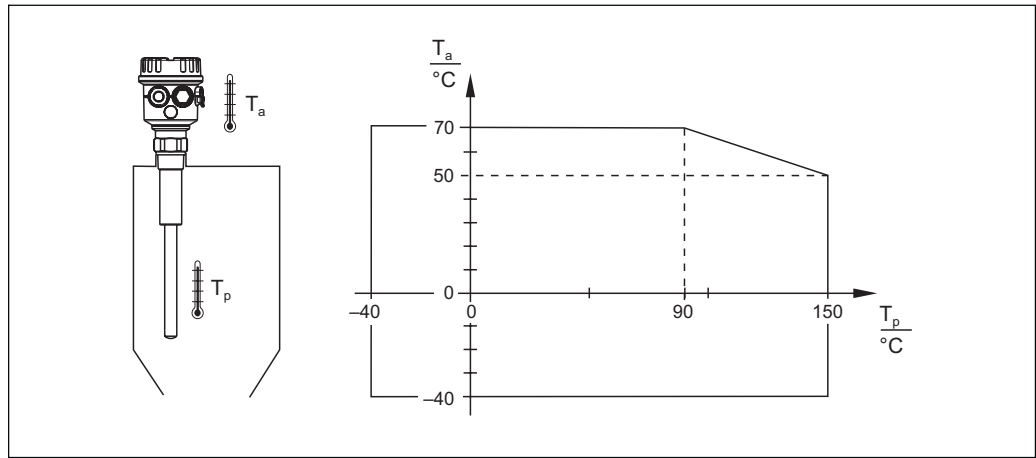

$$x \text{ C} = (1.8x + 32) \text{ F}$$

Thermal shock resistance

Maximum 120 K

Limiting medium pressure range

-1...25 bar

Maximum Working Pressure (MWP)
25 bar

Burst pressure
100 bar

State of aggregation

Solids

Grain size

25 mm

Bulk density

≥ 200 g/l, not fluidised

Lateral load

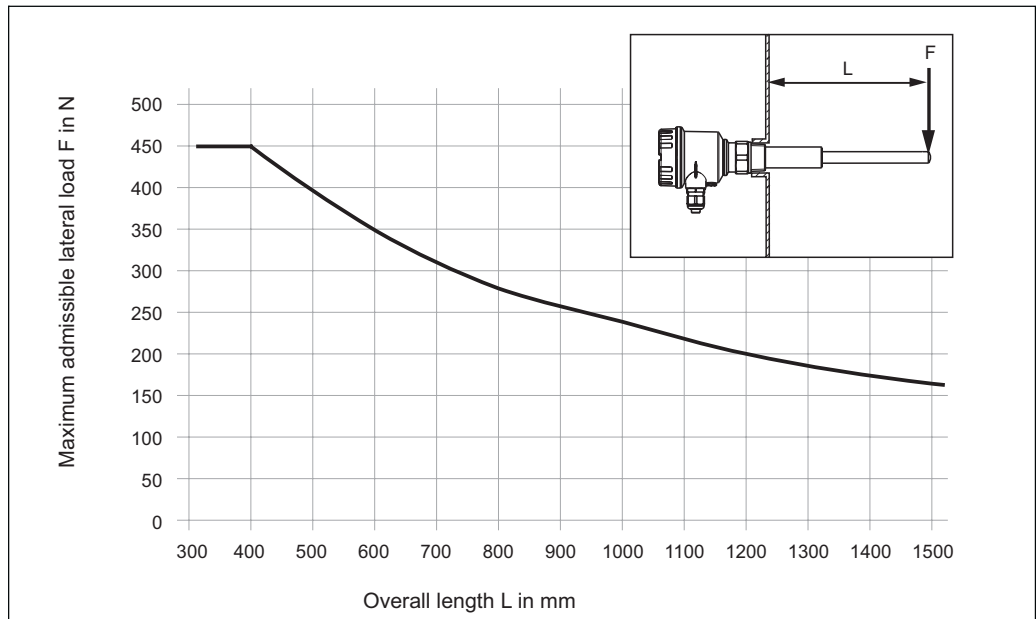

100 mm = 3.94 in

Mechanical construction



Note!
All dimensions in mm! (100 mm = 3.94 in)

Design, dimensions

Compact version

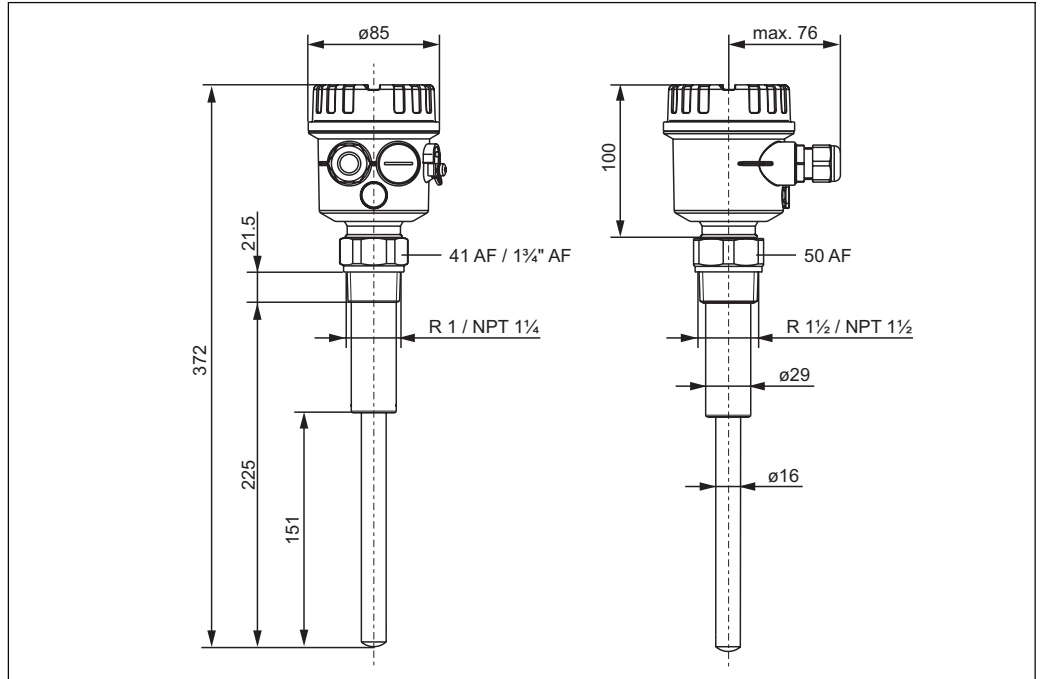

Pipe extension

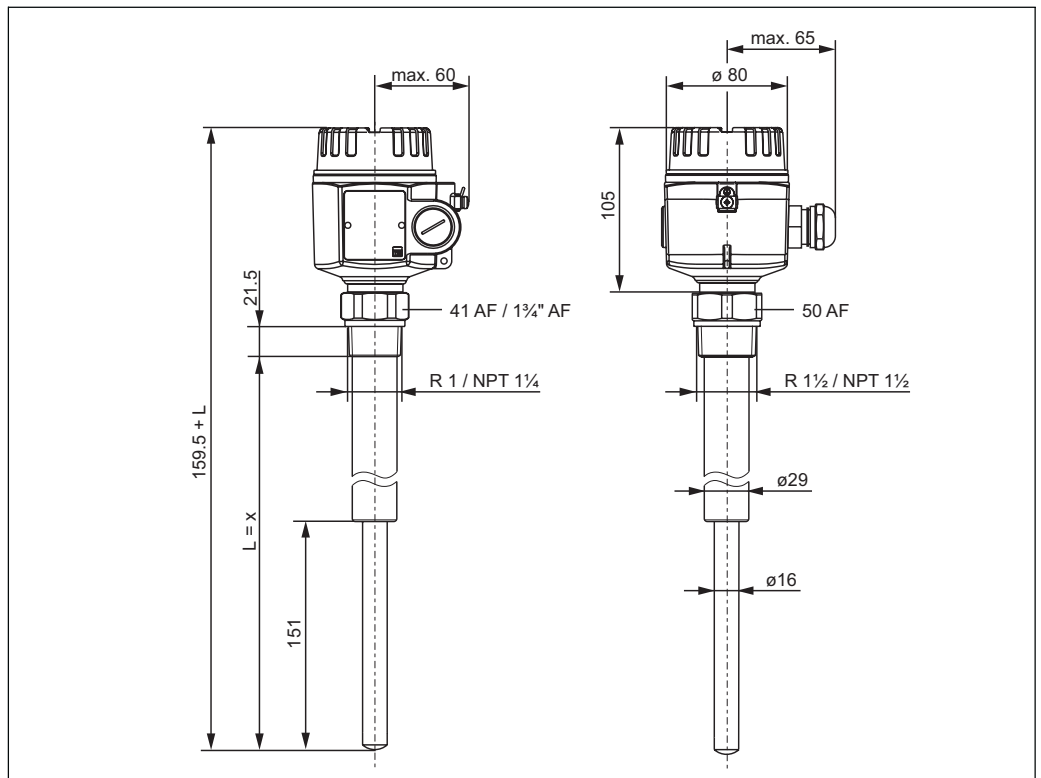

x = 500 mm; 1000 mm; 1500 mm; 20 in; 40 in; z0 in

Weight VFS40/VFS41 with F16 housing, FEM24 and R 1 thread:

Compact = approx. 1.0 kg
 500 mm = approx. 1.3 kg
 1000 mm = approx. 2.0 kg
 1500 mm = approx. 2.6 kg

Material F16 housing:
 PTB-FR, cover with sight glass made of PA12, EPDM cover seal

F18 housing:
 Aluminium EN-AC-ALSi10Mg, plastic-coated
 EPDM cover seal

Process connections:

- R1; R1 (316L, DIN 2999)
- NPT 1¼ - 11 ; NPT 1 - 11 (316L, ANSI B 1.20.1)

Sensor:
 316L

Human interface

Display elements



Note!
 The switch settings in the following graphics are in the as-delivered state.

FEM22

One green LED: operation

One yellow LED: electronic switch closed

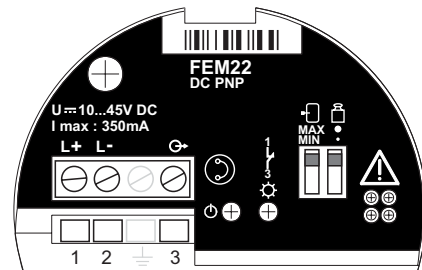

L00-FEM22xxx-07-05-xx-xx-001

FEM24

One green LED: operation

One yellow LED: contact closed
 (relay energised or fed with current)

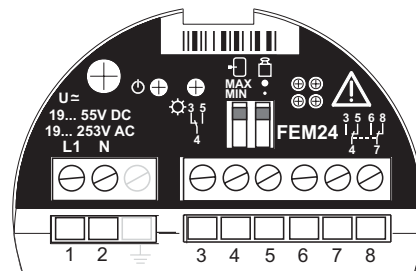

L00-FEM24xxx-07-05-xx-xx-002

Operating elements of
electronic inserts
FEM22 and FEM24

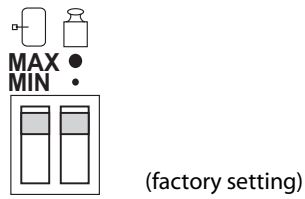

L00-FTM2xxxx-19-05-xxx-xxx-002

 One switch for safety mode

MAX Overfill protection
MIN Dry running protection

 One switch for bulk density/density setting

- 400 g/l (high bulk density)
- 200 g/l (low bulk density)

Sediment detection

Detection of solids under water

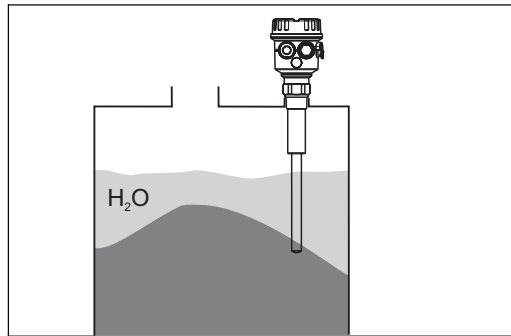

The system does not detect coverage by liquids similar to water.

Certificates and approvals

CE mark, declaration of conformat	<p>The instrument is designed to meet state-of-the-art safety requirements, has been tested and left the factory in a condition in which it is safe to operate.</p> <p>The instrument complies with the applicable standards and regulations as listed in the EC declaration of conformity and thus complies with the statutory requirements of the EG directives.</p> <p>Endress+Hauser confirms the successful testing of the instrument by affixing to it the CE mark.</p>
Ex approval	<p>Your Endress+Hauser sales centre can provide you with information on the Ex versions which can currently be delivered.</p> <p>All explosion protection data are given in a separate documentation (see "Supplementary Documentation") which is available upon request.</p> <p>Copies of certificates available upon request.</p>
Type of protection	<p>See "Ordering information" as of Page 13 and "Supplementary documentation" on Page 16.</p>
Other standards and guidelines	<p>Other standards and guidelines that were taken into consideration in designing and developing Vibrocont VFS40, VFS41:</p> <ul style="list-style-type: none"> • Low Voltage Directive (73/23/EEC) • DIN EN 61010 Part 1, 2001 Protection Measures for Electrical Equipment for Measurement, Control, Regulation and Laboratory Procedures Part 1: General requirements • EN 61326 Electrical Equipment for Measurement, Control and Laboratory Use EMC requirements

Ordering information

Vibrocont VFS40

10		Approval			
	A	Non-hazardous area			
	C	CSA General Purpose, CSA C US			
	D	CSA DIP+FM DIP			
	Y	Special version			
	4	ATEX II 1/3 D			
20		Process connection			
	A	Thread, DIN2999	R1,	316L	
	G	Thread, DIN2999	R1 ,	316L	
	M	Thread, ANSI	NPT1¼,	316L	
	N	Thread, ANSI	NPT1 ,	316L	
	Y	Special version			
30		Electronics; output			
	2	FEM22:	3-wire PNP,	10... 45 V DC	
	4	FEM24:	Relay DPDT,	19...253 V AC / 55 V DC	
	8	FEM20B	ASI Bus		
	9	Special version			
40		Housing; cable entr			
	2	F16	Polyester	IP66/IP67, NEMA4X	M20 gland
	3	F16	Polyester	IP66/IP67, NEMA4X	Thread, NPT
	4	F16	Polyester	IP66/IP67, NEMA4X	Thread, G
	5	F18	Aluminium	IP66/IP67, NEMA4X	M20 gland
	6	F18	Aluminium	IP66/IP67, NEMA4X	Thread, NPT¾
	7	F18	Aluminium	IP66/IP67, NEMA4X	Thread, G
	9	Special version			
50		Additional fittings			
	A	Basic version			
	Y	Special version			
VFS40					Complete product designation

Vibrocont VFS41

10		Approval			
	A	Non-hazardous area			
	C	CSA General Purpose, CSA C US			
	D	CSA DIP+FM DIP			
	Y	Special version			
	4	ATEX II 1/3 D			
20		Process connection			
	A	Thread, DIN2999	R1,	316L	
	G	Thread, DIN2999	R1 ,	316L	
	M	Thread, ANSI	NPT1¼,	316L	
	N	Thread, ANSI	NPT1 ,	316L	
	Y	Special version			
25		Sensor length			
	2	500 mm			
	3	1000 mm			
	4	1500 mm			
	6	20 inch			
	7	40 inch			
	8	60 inch			
	9	Special version			
30		Electronics; output			
	2	FEM22:	3-wire PNP,	10...45 V DC	
	4	FEM24:	Relay DPDT,	19...253 V AC / 55 V DC	
	8	FEM20B	ASI Bus		
	9	Special version			
40		Housing; cable entr			
	2	F16	Polyester	IP66/IP67, NEMA4X	M20 gland
	3	F16	Polyester	IP66/IP67, NEMA4X	Thread, NPT
	4	F16	Polyester	IP66/IP67, NEMA4X	Thread, G
	5	F18	Aluminium	IP66/IP67, NEMA4X	M20 gland
	6	F18	Aluminium	IP66/IP67, NEMA4X	Thread, NPT¾
	7	F18	Aluminium	IP66/IP67, NEMA4X	Thread, G
	9	Special version			
50		Additional fittings			
	A	Basic version			
	Y	Special version			
VFS41		Complete product designation			

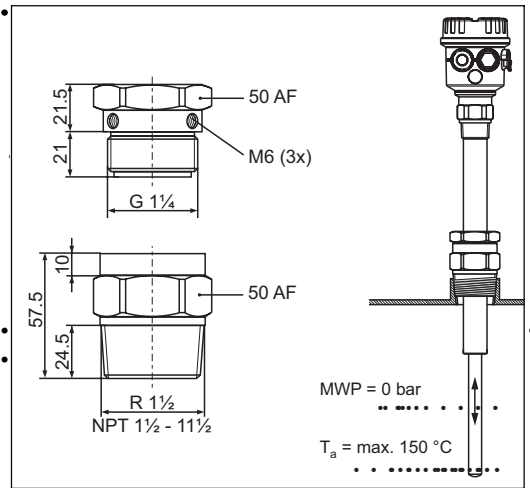
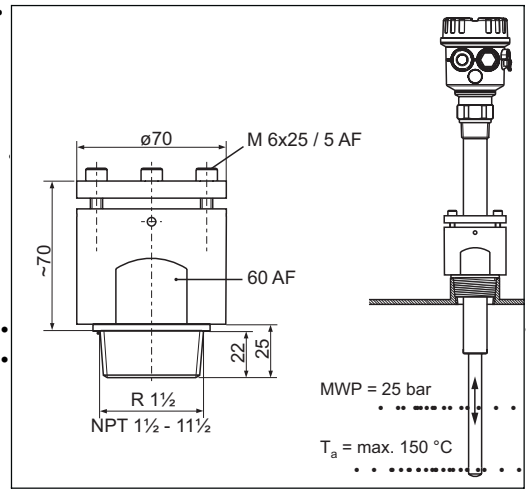

ACS-CONTROL-SYSTEM
knowledge and systems

Your partner for measuring technology and automation



ACS-Control-System GmbH
Lauterbachstr. 57
D- 84307 Eggenfelden

Tel: +49 (0) 8721-9668-0
Fax: +49 (0) 8721-9668-30

info@acs-controlsystem.de
www.acs-controlsystem.de