

nivotester **FTL 375 P-###1**

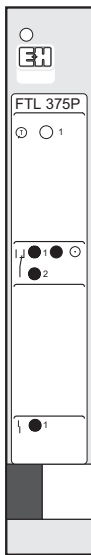

- d** Füllstandgrenzschalter mit PFM-Eingang
- e** Level Limit Switch with PFM input
- f** Détecteur de niveau avec entrée PFM
- es** Detector de nivel con entrada PFM
- i** Interruttore di livello con ingresso PFM
- nl** Niveauschakelaar met PFM ingang

d Inhalt

Sicherheitshinweise	4
Geräte-Identifikation	6
Messeinrichtung	8
Einbau	9
Anschluss	11
Einstellungen	14
Anzeige- und Bedienelemente	15
Funktion	16
Funktionstest	18
Technische Daten	32
Fehlersuche	34
Ergänzende Dokumentation	40

e Contents

Notes on Safety	4
Device Identification	6
Measuring system	8
Installation	9
Connection	11
Setting-up	14
User interface elements	15
Function	16
Function test	18
Technical Data	32
Trouble-shooting	35
Supplementary Documentation	40

f Sommaire

Conseils de sécurité	4
Désignation de l'appareil	6
Ensemble de mesure	8
Montage	9
Raccordement	11
Réglages	14
Eléments d'affichage et de commande	15
Fonctionnement	16
Test de fonctionnement	18
Caractéristiques techniques	32
Recherche de défauts	36
Documentation complémentaire	40

es	Indice		i	Indice		nl	Inhoud	
	Notas sobre seguridad	5		Note sulla sicurezza	5		Veiligheidsinstructies	5
	Identificación del equipo	6		Identificazione dello strumento	6		Instrument-identificatie	6
	Sistema de medida	8		Sistema di misura	8		Meetopstelling	8
	Montaje	9		Montaggio	9		Inbouw	9
	Conexiones	11		Collegamenti	11		Aansluiting	11
	Ajuste	14		Messa in marcia	14		Instellingen	14
	Elementos de indicación y función	15		Elementi sul frontale	15		Bedienings- en aanwijselementen	15
	Funcionamiento	16		Funzione	16		Functie	16
	Prueba de funcionamiento	19		Test di funzionalità	19		Functie test	19
	Datos técnicos	33		Dati tecnici	33		Technische gegevens	33
	Identificación de fallos	37		Individuazione e eliminazione delle anomalie	38		Fout zoeken	39
	Documentación adicional	40		Documentazione supplementare	40		Aanvullende documentatie	40

d Sicherheitshinweise
Der Nivotester FTL 375 P darf nur als Messumformer-Speisegerät für Grenzschalter von E+H mit Zweidraht-PFM-Signal verwendet werden.

Bei unsachgemäßem Einsatz können Gefahren von ihm ausgehen.



Das Gerät **darf nur von qualifiziertem und autorisiertem Fachpersonal** unter strenger Beachtung dieser Betriebsanleitung, der einschlägigen Normen, der gesetzlichen Vorschriften und der Zertifikate (je nach Anwendung) eingebaut, angeschlossen, in Betrieb genommen und gewartet werden.

->  XA 147F
Sicherheitshinweise in XA 147F beachten!

e Notes on Safety
The Nivotester FTL 375 P may only be used as a measuring transmitter power supply for E+H limit switches with two-wire PFM signals.

If used incorrectly it is possible that application-related dangers may arise.



The level limit device may be installed, connected, commissioned, operated and maintained **by qualified and authorised personnel only**, under strict observance of these operating instructions, any relevant standards, legal requirements, and, where appropriate, the certificate.

->  XA 147F
Note the safety instructions in XA 147F!

f Conseils de sécurité
Le Nivotester FTL 375 P doit exclusivement être utilisé comme alimentation de transmetteur pour détecteurs de niveau E+H avec signal PFM 2 fils.

Il peut être source de danger en cas d'utilisation non conforme aux prescriptions.

L'appareil ne doit être installé, raccordé, mis en service et maintenu **que par un personnel qualifié et autorisé**, qui tiendra compte des indications contenues dans la présente mise en service, des normes en vigueur et des certificats disponibles (selon l'application).

->  XA 147F
Tenir compte des conseils de sécurité dans XA 147F!

es Notas sobre seguridad

El Nivotester FTL 375 P debe utilizarse únicamente como fuente de alimentación de detectores de nivel E+H con señales PFM de dos hilos.

Su empleo inapropiado puede resultar peligroso.

El equipo deberá ser montado, conectado, instalado y mantenido única y **exclusivamente por personal cualificado y autorizado**, bajo rigurosa observación de las presentes instrucciones de servicio, de las normativas y legislaciones vigentes, así como de los certificados (dependiendo de la aplicación)



Notas sobre seguridad
en XA 147F!

i Note sulla sicurezza

Il Nivotester FTL 375 P può essere usato solo per alimentare sensori E+H in tecnologica PFM.

Un'installazione non corretta può determinare pericolo.

Lo strumento FTL 375 P deve essere montato, connesso, messo in funzione ed operato **solamente da personale qualificato ed autorizzato**, sotto la stretta osservazione delle presenti norme di installazione e di manutenzione e delle ulteriori norme, regolamenti, disposizioni legali e, dove richiesto, dei certificati appropriati.



Vedere istruzioni di sicurezza
in XA 147F!

nl Veiligheidsinstructies

De niveautester FTL 375 P mag alleen als meetversterker/voeding voor niveauschakelaars met 2-draads PFM signalen, van E+H worden gebruikt.

Indien niet correct gebruikt kunnen gevaarlijke situaties ontstaan.

Het instrument alleen door **gekwalificeerd en geautoriseerd personeel** laten inbouwen, aansluiten, in bedrijf nemen en onderhouden.

Neem de instructies in deze Inbedrijfstellingsvoorschriften de desbetreffende normen, de wettelijke voorschriften en eventuele certificaten in acht.



Veiligheidsinstructies
XA 147F in acht nemen!

d Geräte-Identifikation

e Device Identification

f Désignation de l'appareil

es Identificación del equipo

i Identificazione dello strumento

nl Instrument-identificatie



F = ATEX II (1) GD, [EEEx ia] IIC, WHG
H = ATEX II (1) GD, [EEEx ia] IIC, WHG, SIL2 (IEC 61508)

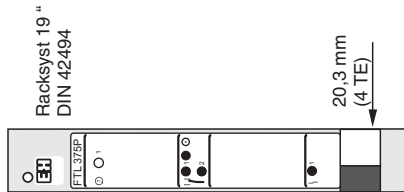

1

9 = *1

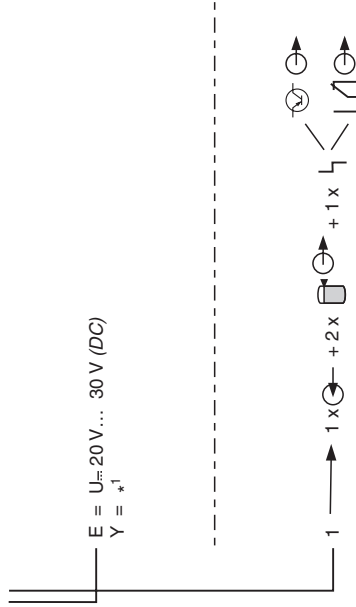

- = Ausgang / Output / Sortie / Salida / Uscita / Uitgang
- = Eingang / Input / Entrée / Acceso / Ingresso / Ingang
- = Grenzsinal / Limit signal / Signal de seuil /
Soglia d'intervento / Señal de límite / Niveausignaal
- = Störung / Fault / Défaut / Fallo / Guasto / Storing

*1 = andere / others / autres / otros / altri / andere

d Messeinrichtung

e Measuring system

f Ensemble de mesure

es Sistema de medida

i Sistema di misura

nl Meetopstelling

Beispiele / Examples / Exemples /
Ejemplo / Esempio / Voorbeeld



Liquiphant FTL

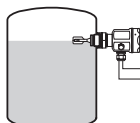

Nivopuls S/C

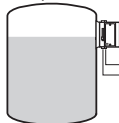

Soliphant FTM

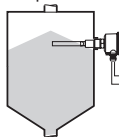

PFM

PFM

PFM

FTL 375 P

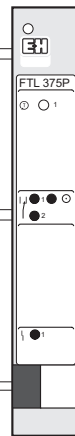

U...

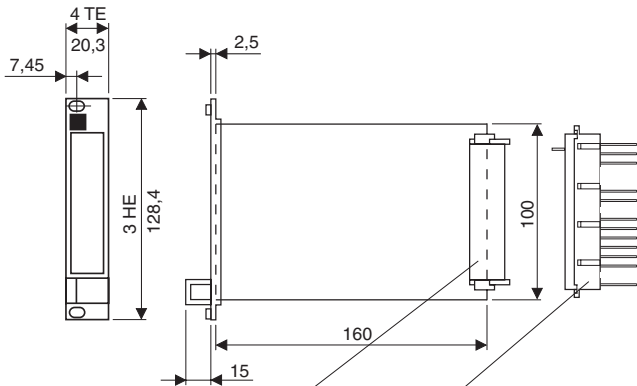

- | | |
|------------------------------|--|
| d Messerleiste | Federleiste mit Codierstiften |
| e Male connector | Female connector with coding pins |
| f Connecteur mâle | Connecteur femelle avec détrompeurs |
| es Conector macho | Conector hembra con pins de codificación |
| i Morsettiera maschio | Morsettiera femmina codificata |
| nl Connector | Connector met codeerpennen |

DIN 41612/3/F

- d Einbau**
in Baugruppenträger
(Feldgehäuse)
- e Installation**
in subrack (field housing)
- f Montage**
dans un rack (boîtier de terrain)
- es Montaje**
en rack (versión de campo)
- i Montaggio**
in cestello Rack
- nl Inbouw**
in 19" rack behuizing

d Codierstifte in die Federleiste stecken, Position 2+14

e Insert coding pins in pos. 2+14 of the female connector

f Emplacement des détrompeurs dans le connecteur femelle, pos. 2+14

es Insertar pins de codificación en pos. 2+14 del conector hembra

i Inserire i pin di codifica nelle pos. 2+14 della morsettiera femmina

nl Codeerpennen in de connector plaatsen, pos. 2+14

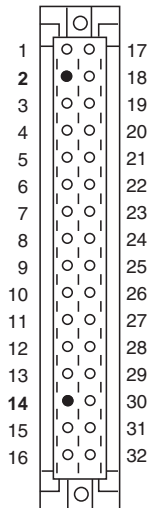
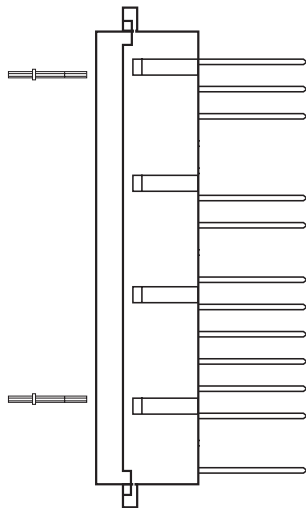

100 mm = 3.94 in

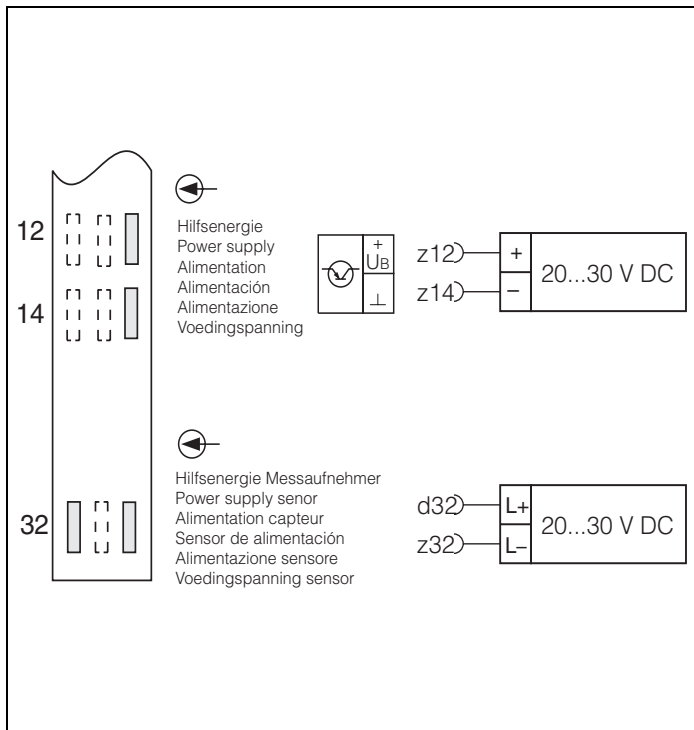

d Anschluss
Hilfsenergie
Federleiste Anschlussseite

e Connection
Power Supply
Connection side of the
female connector

f Raccordement
Alimentation
Connector femelle,
coté raccordement

es Conexiones
Alimentación
Conector hembra,
lado de conexión

i Collegamenti
Alimentazione
Morsettiere femmina,
parte connessioni

nl Aansluiting
Voedingsspanning
Aansluitzijde van de connector

d Anschluss des
Messaufnehmers

e Sensor connection

f Raccordement du capteur

es Conexión de sensor

i Connessione sensore

nl Aansluiting van de sensor

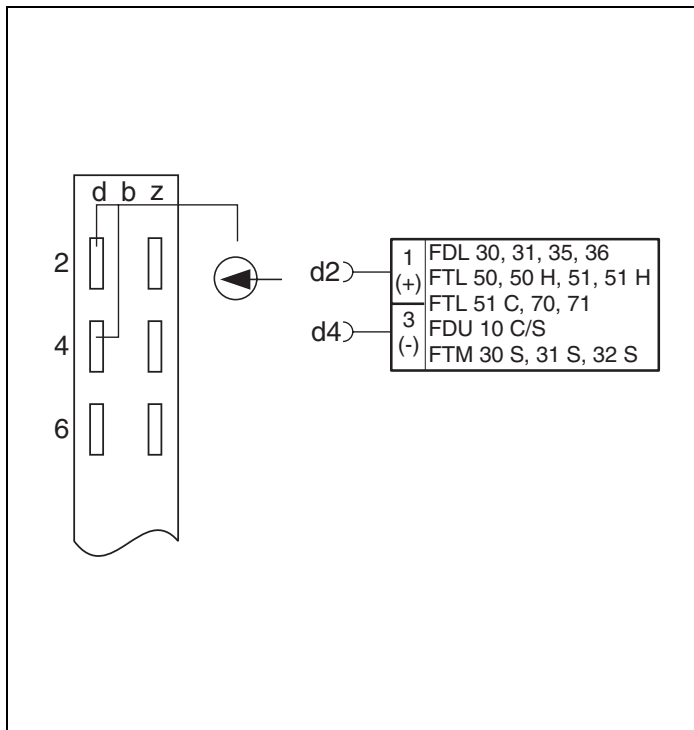

d **Einstellungen**
Minimum/Maximum
Sicherheitsschaltung
einstellen

e **Setting-up**
Adjust minimum/maximum
fail-safe mode

f **Réglages**
Réglage commutateur de
sécurité minimum/maximum

es **Ajuste**
Ajustar conexión de seguridad
mínima/máxima

i **Messa in marcia**
Impostare il tipo di sicurezza
min/max

nl **Instellingen**
Instelling minimaal/maximaal
fail safe veiligheidschakeling

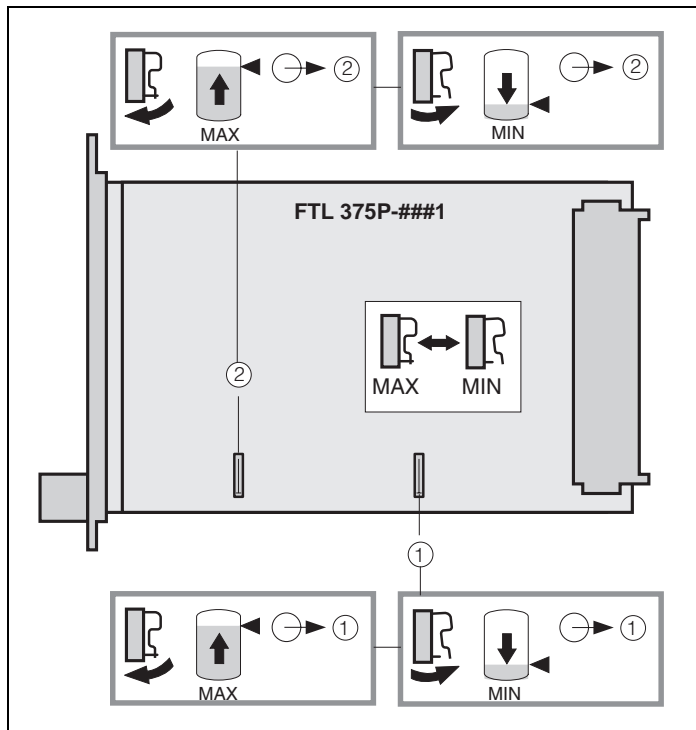

Gelbe Leuchtdiode
"Relais Ausgang angezogen."

Yellow LED
"Output relay picked-up."

DEL jaune
"Relais de sortie attiré."

LED amarillo
"Relé de salida activado."

LED giallo
"Di stato dei relè."

Gele LED
"Relais uitgang aangetrokken"

Rote Leuchtdiode: "Störung"

Red LED: "Fault"

DEL rouge : "Défaut"

LED rojo: "Fallo"

LED rosso: "di allarme"

Rode LED: "Storing"

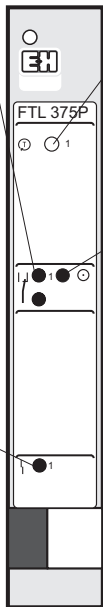

Prüftaste
Test button
Touche test
Botón de prueba
Pulsante di test
Testtoet

Grüne Leuchtdiode
"Betrieb"

Green LED
"on"

DEL verte
"on"

LED verde
"iluminado"

LED verde
"di funzionamento"

Groene LED
"in bedrijf"

d Anzeige- und
Bedienelemente

e User interface elements

f Eléments d'affichage et
de commande

es Elementos de indicación
y función

i Elementi sul frontale

nl Bedienings- en
aanwijzelementen

d Funktion**e Function****f Fonctionnement****es Funcionamiento****i Funzione****nl Functie**

Maximum-Sicherheitschaltung
 Maximum fail-safe mode
 Sécurité maximum
 Conmutador de seguridad máx.
 Selezione della modalità di
 sicurezza max.
 Maximum veiligheidsschakeling



Füllstand Level Niveau Nivel Livello Niveau	Signalübertragung Signal trans. Trans. de signal Trans. de la señal Trans. di segnale Signaaloverdracht				YE GN YE GN RD
					YE GN YE GN RD
					YE GN YE GN RD
Störung Fault Défaut Fallo Guasto Storing					YE GN YE GN RD
0 V					YE GN YE GN RD

GN = grün / green / vert / verde / verde / groen
 RD = rot / red / rouge / rojo / rosso / rood
 YE = gelb / yellow / jaune / amarillo / giallo / geel

Füllstand Level Niveau Nivel Livello Niveau	Signalübertragung Signal trans. Trans. de signal Trans. de la señal Trans. di segnale Signaloverdracht				YE GN YE RD
					YE GN YE RD
					YE GN YE RD
Störung Fault Défaut Fallo Guasto Storing					YE GN YE RD
0 V					YE GN YE RD

GN = grün / green / vert / verde / verde / groen
 RD = rot / red / rouge / rojo / rosso / rood
 YE = gelb / yellow / jaune / amarillo / giallo / geel

Minimum-Sicherheitschaltung
Minimum fail-safe mode
Sécurité minimum
Conmutador de seguridad mín.
Selezione della modalità di
sicurezza min.
Minimum veiligheidsschakeling

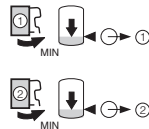

d Funktionstest

Mit Messaufnehmer:

- Liquiphant DL 17 Z
- Liquiphant FDL 30/31/35/36

Die Prüftaste des FTL 375 P drücken.

Funktion ist abhängig von der Sicherheitsschaltung.

Die Prüftaste des FTL 375 P loslassen:

Rückkehr zum normalen Betrieb.

e Function test

With measuring transmitter:

- Liquiphant DL 17 Z
- Liquiphant FDL 30/31/35/36

Press the test key on the FTL 375 P.

Function is dependent on the safety circuit.

Release the test key on the FTL 375 P:

Return to normal mode.

f Test de fonctionnement

Avec capteur :

- Liquiphant DL 17 Z
- Liquiphant FDL 30/31/35/36

Activer la touche-test du FTL 375 P.

Le fonctionnement dépend du circuit de sécurité.

Relâcher la touche-test :

Retour au mode normal.

es Prueba de funcionamiento

Con los detectores:

- Liquiphant DL 17 Z
- Liquiphant FDL 30/31/35/36

Presione el botón de prueba del FTL 375 P.

El funcionamiento depende del circuito de seguridad.

Deje de presionar el botón de prueba del FTL 375 P:

Retorno a modo normal.

i Test di funzionalità

Con sensori:

- Liquiphant DL 17 Z
- Liquiphant FDL 30/31/35/36

Premere il pulsante del FTL 375 P.

Commutazione come da sicurezza scelta.

Rilasciare il pulsante:

Ritorno al modo normale.

nl Functietest

Met sensor:

- Liquiphant DL 17 Z
- Liquiphant FDL 30/31/35/36

De testkop van de FTL 375 P indrukken.

Functie is afhankelijk van de veiligheidsschakeling.

De testknop van de FTL 375 P loslaten:

Terug naar normaal bedrijf.

d Funktionstest
der Messeinrichtung

Mit Messaufnehmer:

- Liquiphant M,
FTL 50 (H) / 51 (H), 51 C
- Liquiphant S FTL 70/71

Funktionskontrolle der Messeinrichtung ohne Füllstandsänderung. (Schwinggabel und Elektroneinsatz FEL 57 des Liquiphant M/S, Leitung und Eingangsschaltung des Schaltgeräts Nivotester FTL 375 P.)

Zugelassen zur wiederkehrenden Prüfung von Überfüllsicherungen.

Hinweis: Bei Spannungsausfall läuft der Selbsttest automatisch ab.

Auswirkungen beachten im Hinblick auf die Funktion Ihrer Anlage. Evtl. Schaltverzögerung vorsehen.

e Function test
of the measuring system

With measuring transmitter:

- Liquiphant M,
FTL 50 (H) / 51 (H), 51 C
- Liquiphant S FTL 70/71

Functional test of the device without a change in level. (Fork and electronic insert FEL 57 of the Liquiphant M/S, connecting cable and input circuit of the Nivotester FTL 375 P.)

Approved for the functional testing of overspill protection devices.

Note: The self test of the electronic insert FEL 57 also runs automatically when the power has failed. Take note of this with regard to the functioning of your plant and if necessary provide a suitable switching delay.

f Test de fonctionnement
de l'ensemble de mesure

Avec capteur:

- Liquiphant M,
FTL 50 (H) / 51 (H), 51 C
- Liquiphant S FTL 70/71

Contrôle du fonctionnement de l'ensemble de mesure sans variation de niveau. (Fourche à lames vibrantes et électronique FEL 57 du Liquiphant M/S, câble et circuit d'entrée du détecteur Nivotester FTL 375 P.)

Agréé pour le test cyclique de sécurités antidébordement.

Remarque: L'autotest de l'électronique FEL 57 a également lieu après chaque coupure de courant. Tenir compte de ceci pour le fonctionnement de votre installation et prévoir le cas échéant une temporisation approuvée.

es Prueba de funcionamiento
del sistema de medición

Con el detector:

- Liquiphant M,
FTL 50 (H) / 51 (H), 51 C
- Liquiphant S FTL 70/71

Prueba de funcionamiento de la unidad, sin cambio en el nivel. (Horquilla y electrónica FEL 57 del Liquiphant M/S, cable de conexión y circuito de entrada del Nivotester.)

Indicado para la comprobación de funcionamiento de equipos de protección contra rebose.

Nota: El sistema de autocomprobación de la electrónica FEL 57 también se activa automáticamente si se ha dado un fallo de alimentación. Ello deberá tenerse en cuenta por lo que se refiere al funcionamiento de la planta, en caso necesario aplicar un temporizador.

i Test di funzionalità
del sistema con sensori

Con sensori:

- Liquiphant M,
FTL 50 (H) / 51 (H), 51 C
- Liquiphant S FTL 70/71

Test funzionale dello strumento senza variazioni di livello. (Forcella e inserto elettronico FEL 57 del Liquiphant M/S, cavo di connessione e circuito di ingresso del Nivotester.)

Approvazione per test funzionali di strumenti di sicurezza antitraboccamento.

Nota: L'autotest dell'inserto elettronico FEL 57 si avvia automaticamente anche in caso di interruzioni di energia. Tenere presente questo comportamento in relazione al funzionamento dell'impianto e, se necessario, prevedere un opportuno ritardo di commutazione.

nl Functietest
van het meetsysteem

Met sensor:





















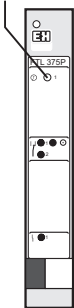

- Liquiphant M,
FTL 50 (H) / 51 (H), 51 C
- Liquiphant S FTL 70/71

Functiecontrole van de sensor zonder niveauverandering. (Vork en elektronicamodule FEL 57 van de Liquiphant M/S, aansluitkabel en ingangscircuit van de Nivotester FTL 375 P.)

Goedgekeurd voor het functioneel testen van overvulbeveiligingen.

Note: Na spanningsuitval wordt de elektronicamodule FEL 57 automatisch getest. Houdt hiermee rekening in uw procesbesturing en pas eventueel een gepaste schakelvertraging toe.

- Liquiphant DL 17 Z
- Liquiphant FDL 30/31,
FDL 35/36

<p>Bei Einstellung With setting Avec réglage Con ajuste Con impostazione Met instelling</p>	<p>Prüftaste drücken Press test button Appuyer sur la touche test</p>	 ▶ CH1	 ▶ Ch2	 ⚡	
 MAX  MAX	<p>Pulse el botón de prueba Premere il pulsante test</p>	 	 	 	
 MIN  MIN 	<p>Testknop indrukken</p>	 	 	 	

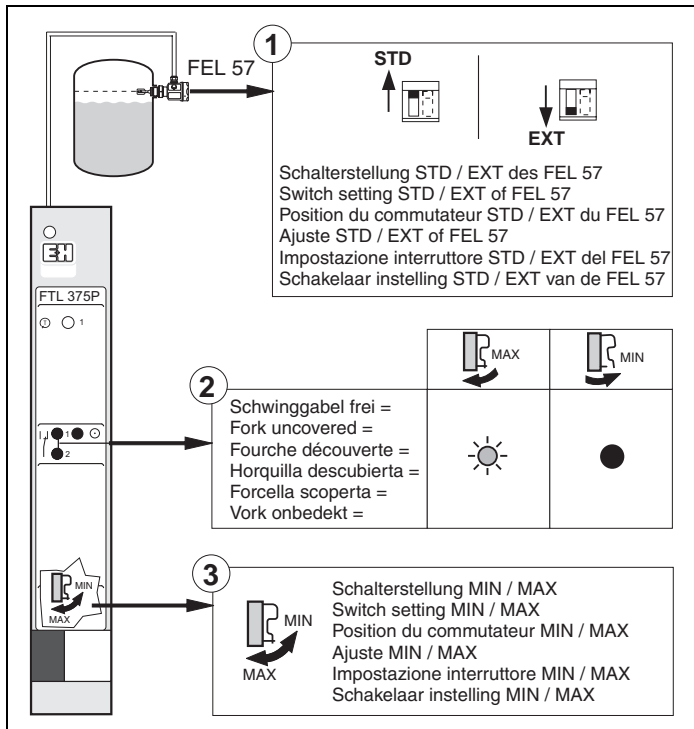

- d** Voraussetzungen
1, 2 und 3 beachten
- e** Conditions
Note 1, 2 and 3
- f** Conditions
Tenir compte de 1, 2 et 3
- es** Requisitos previos
Comprobar 1, 2 y 3
- i** Prerequisiti
1, 2 e 3
- nl** Uitgangssituatie
1, 2 en 3 bekijken

- Liquiphant M
FTL 50 (H)/51 (H), 51 C
- Liquiphant S FTL 70/71

d Erläuterungen:

Der Testablauf kann nur vollständig beobachtet werden, wenn

- die Schwinggabel des Liquiphant M/S frei ist und
- der Nivotester FTL 375 P in Maximum-Sicherheits-schaltung betrieben wird (Wiederkehrende Prüfung für Überfüllsicherung) oder
- der Nivotester FTL 375 P in Minimum-Sicherheits-schaltung betrieben wird.

Der Liquiphant M/S Selbsttest findet zwar unabhängig von der Bedeckung der Schwinggabel statt, **bei bedeckter Schwinggabel ist jedoch die einwandfreie Funktion während der Testphase nicht erkennbar.**

e Explanations:

The test procedure can be properly observed when:

- the fork of the Liquiphant M/S is uncovered and
- the Nivotester FTL 375 P is operated in maximum fail-safe mode (functional test for overspill protection) or
- the Nivotester FTL 375 P is operated in minimum fail-safe mode.

The Liquiphant M/S self test runs independent of the fork being covered, **however, if this is the case, proper functioning cannot be recognised during the test phase.**

f Explications :

Le déroulement du test ne peut être observé dans sa totalité que si

- les lames vibrantes du Liquiphant M/S sont découvertes et
- le Nivotester FTL 375 P fonctionne en sécurité maximum (test cyclique pour sécurité anti-débordement) ou
- le Nivotester FTL 375 P fonctionne en sécurité minimum.

L'auto-test du Liquiphant M/S est indépendant du recouvrement des lames vibrantes, mais lorsque ces dernières sont recouvertes, **il n'est pas possible de reconnaître le fonctionnement correct en phase de test.**

es Explicación:

La prueba podrá observarse adecuadamente si:

- la horquilla del Liquiphant M/S está descubierta
- y
- el Nivotester FTL 375 P funciona en modo de seguridad máximo (comprobación de protección contra rebose)
- o
- el Nivotester FTL 375 P funciona en modo de seguridad mínimo.

El sistema de autocomprobación del Liquiphant M/S se activa independientemente de **que la horquilla esté cubierta, sin embargo, si es así, durante el test no es posible comprobar el buen funcionamiento.**

i Chiarimenti:

La procedura di prova può essere eseguita

correttamente se:

- la forcella del Liquiphant M/S è scoperta e
- il Nivotester FTL 375 P funziona con modalità di sicurezza di massimo (test funzionale di protezione antitraboccamento) oppure
- il Nivotester FTL 375 P funziona con modalità di sicurezza di minimo.

L'autotest del Liquiphant M/S viene eseguito anche se **la forcella è coperta, in questo caso però; non è possibile riconoscere il corretto funzionamento durante il test.**

nl Verklaringen:

De testprocedure wordt optioneel uitgevoerd als:

- de vork van de Liquiphant M/S vrij is en
- de Nivotester FTL 375 P in maximum-fail-safe keuze staat (functietest voor overvulbeveiliging) of
- de Nivotester FTL 375 P in minimum-fail-safe keuze staat.

De functietest van de Liquiphant M/S werkt onafhankelijk van de bedekking van de trilvork. **Bij bedekte sensor is het correct functioneren, tijdens de testfase, echter niet te herkennen.**

d Weitere Erläuterungen

e Further explanations

f Autres explications

es Más información

i Altre spiegazioni

nl Meer informatie

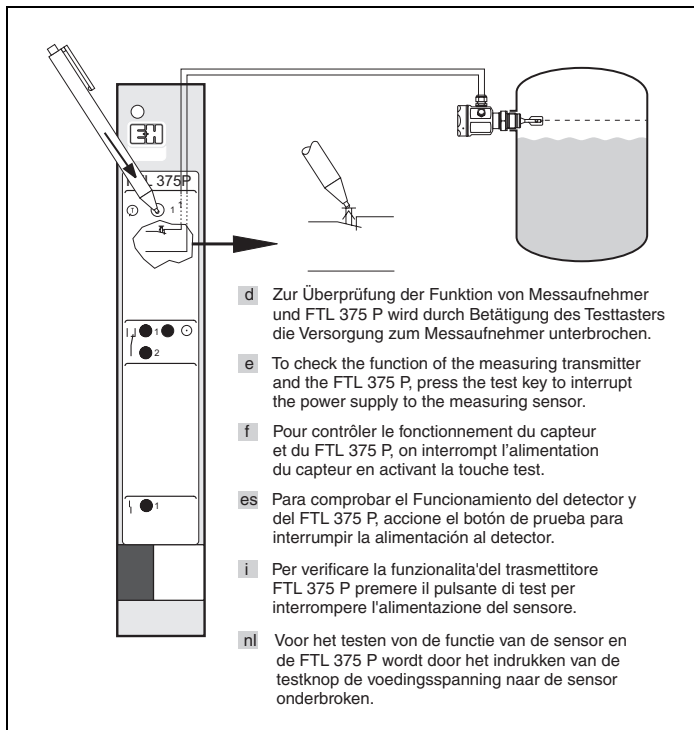

d Zur Überprüfung der Funktion von Messaufnehmer und FTL 375 P wird durch Betätigung des Testtasters die Versorgung zum Messaufnehmer unterbrochen.

e To check the function of the measuring transmitter and the FTL 375 P, press the test key to interrupt the power supply to the measuring sensor.

f Pour contrôler le fonctionnement du capteur et du FTL 375 P, on interrompt l'alimentation du capteur en activant la touche test.

es Para comprobar el Funcionamiento del detector y del FTL 375 P, accione el botón de prueba para interrumpir la alimentación al detector.

i Per verificare la funzionalità del trasmettitore FTL 375 P premere il pulsante di test per interrompere l'alimentazione del sensore.

nl Voor het testen van de functie van de sensor en de FTL 375 P wordt door het indrukken van de testknop de voedingsspanning naar de sensor onderbroken.

- 1** Prüftaste drücken
 Press test button 
 Activer la touche test
 Presionar el botón de prueba
 Premere il tasto di prova
 Testtoets drukken

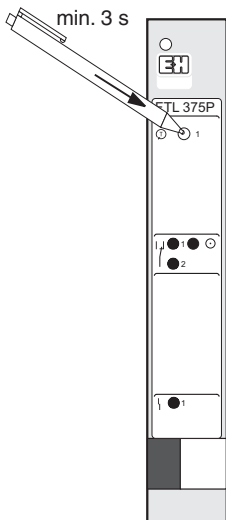

- 2**  30.....33
- Ablauf beobachten
 Observe sequence
 Observer le déroulement
 Observar la secuencia
 Osservare la sequenza
 Volgorde bekijken

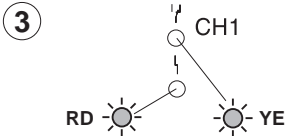

- d** Funktion ist abhängig von der Sicherheitsschaltung und kann daher unterschiedlich sein.
- e** The function is dependent upon the fail-safe mode and can thus be different.
- f** Le fonctionnement, qui dépend du mode de sécurité, peut varier.
- es** El funcionamiento depende del modo de seguridad y por tanto puede ser diferente.
- i** Il funzionamento dipende dalla modalità di sicurezza e pertanto può variare.
- nl** Functie is afhankelijk van de fail-safe keuze en kan daarom anders zijn.

- d** Testverlauf
- e** Test procedure
- f** Déroulement du test
- es** Procedimiento de prueba
- i** Procedura di prova
- nl** Testprocedure

Nivotester FTL 375 P-###1

Liquiphant M/S FTL 5#/7#
+ FEL 57:

STD



☀ YE = gelb / yellow / jaune /
amarillo / giallo / geel
☀ RD = rot / red / rouge /
rojo / rosso / rood

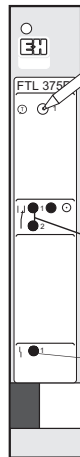

0 1 2 3 4 5 ...



























Liquiphant M/S
FTL 5#/7# + FEL 57

GN

YE



Betrieb
Operation
Fonctionnement
Funcionamiento
Funzionamento
Bedrijf

Teststart Test start Début de test Inicio prueba Avvio test Test start	Testphase Test phase Phase de test Fase de prueba Fase di test Test fase	Normaler Betrieb Normal operation Fonctionnement normal Funcionamiento normal Funzionamento normale Normaal bedrijf
min. ↓ 3 s ↓ 		
0 1 2 3 ...	0 1 2 3 4 5 6 7 8 9 10 ...	
	  	
 	  	
	 	
		
	  	

Nivotester FTL 375 P-###1

Liquiphant M/S FTL 5#/7#
+ FEL 57:



EXT

- ☀ YE = gelb / yellow / jaune /
amarillo / giallo / geel
- ☀ RD = rot / red / rouge /
rojo / rosso / rood

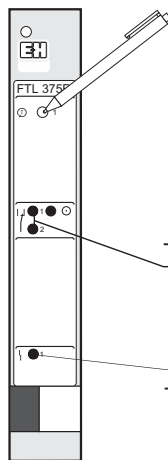

	Betrieb Operation Fonctionnement Funcionamiento Funzionamento Bedrijf	Teststart Test start Début de test Inicio prueba Avvio test Test start
		min. ↓ 3 s
[S]	0 1 2 3 4 ...	0 1 2 3 ...
	☀	●
	●	☀ ●
	●	☀
Liquiphant M/S FTL 5#/7# + FEL 57	GN YE	● ●

Testphase
 Test phase
 Phase de test
 Fase de prueba
 Fase di test
 Test fase

Normaler Betrieb
 Normal operation
 Fonctionnement normal
 Funcionamiento normal
 Funzionamento normale
 Normaal bedrijf



0 1 2 3 4 5 6 7 37 38 39 40 41 42 43 44 ...

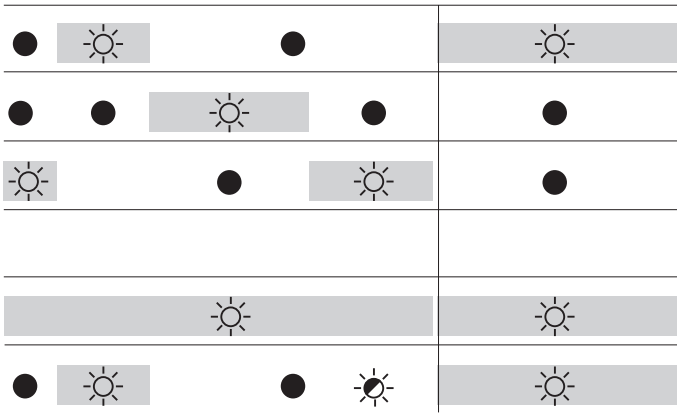

d Technische Daten

Hilfsenergie für FTL 375 P
und Transistorausgänge:

20...30 V DC

Restwelligkeit: max. 2 V

Schaltleistung Relaiskontakte:

- U_{\sim} max. 253 V
- I_{\sim} max. 2,5 A
- P_{\sim} max. 600 VA/cos $\varphi = 1$
- P_{\sim} max. 300 VA/cos $\varphi \geq 0,7$
- U_{-} max. 100 V
- I_{-} max. 2,5 A
- P_{-} max. 100 W

Bei gleichzeitigem Anschluss
an Funktionskleinspannungs-
stromkreis mit sicherer

Trennung:

max. 50 V AC, 2,5 A

Transistorausgänge:

- Ausgang high:
typ. 24 V/500 mA
- Ausgang low: < 100 mV
- kurzschlussfest

e Technical Data

Power supply for FTL 375 P
and transistor outputs:

20...30 V DC

Residual ripple: max. 2 V

Relay contact switching
capacity:

- U_{\sim} max. 253 V
- I_{\sim} max. 2,5 A
- P_{\sim} max. 600 VA/cos $\varphi = 1$
- P_{\sim} max. 300 VA/cos $\varphi \geq 0,7$
- U_{-} max. 100 V
- I_{-} max. 2,5 A
- P_{-} max. 100 W

When simultaneously
connected to low-voltage
function circuit with safe
disconnection:

max. 50 V AC, 2,5 A

Transistor outputs:

- Output high:
typ. 24 V/500 mA
- Output low: < 100 mV
- short-circuit-proof

f Caractéristiques techniques

Alimentation pour FTL 375 P
et sorties transistor :

20...30 V DC

Ondulation résiduelle : max. 2 V

Puissance de coupure des
contacts de relais :

- U_{\sim} max. 253 V
- I_{\sim} max. 2,5 A
- P_{\sim} max. 600 VA/cos $\varphi = 1$
- P_{\sim} max. 300 VA/cos $\varphi \geq 0,7$

- U_{-} max. 100 V
- I_{-} max. 2,5 A
- P_{-} max. 100 W

En cas de raccordement
simultané à un circuit faible
tension avec mise hors circuit :
max. 50 V AC, 2,5 A

Sorties transistor :

- Sortie max. :
typ. 24 V/500 mA
- Sortie min. : < 100 mV
- résistance aux court-circuits

es Datos técnicos

Tensión de alimentación para FTL 375 P y salidas de transistor: 20...30 V DC
Rizado residual: máx. 2 V

Capacidad conexión contacto de relé:

- U~ max. 253 V
- I~ max. 2,5 A
- P~ max. 600 VA/cos $\varphi = 1$
- P~ max. 300 VA/cos $\varphi \geq 0,7$

- U– max. 100 V
- I– max. 2,5 A
- P– max. 100 W

Si se conecta simultáneamente al circuito de función de bajo voltaje con desconexión segura: máx. 50 V AC, 2,5 A

Salidas transistor:

- Salida alta:
Típica 24 V/500 mA
- Salida baja: < 100 mV
- Prueba cortocircuito

i Dati tecnici

Alimentazione per FTL 375 P e uscite a transistore: 20...30 V DC
Ripple residuo: max. 2 V

Capacità di commutazione dei contatti relé:

- U~ max. 253 V
- I~ max. 2,5 A
- P~ max. 600 VA/cos $\varphi = 1$
- P~ max. 300 VA/cos $\varphi \geq 0,7$

- U– max. 100 V
- I– max. 2,5 A
- P– max. 100 W

Quando connessi simultaneamente a un circuito di bassa tensione di sicurezza: máx. 50 V AC, 2,5 A

Uscite transistore:

- Uscita alta:
tipico 24 V/500 mA
- Uscita bassa: < 100 mV
- protezione cortocircuito

nl Technische gegevens

Voeding voor FTL 375 P en transistor uitgangen: 20...30 V DC
Restrimpel: max. 2 V

Schakelvermogen van de relaiscontacten:

- U~ max. 253 V
- I~ max. 2,5 A
- P~ max. 600 VA/cos $\varphi = 1$
- P~ max. 300 VA/cos $\varphi \geq 0,7$

- U– max. 100 V
- I– max. 2,5 A
- P– max. 100 W

Indien gelijktijdig verbonden met een laagspanningscircuit met een veilige scheiding: máx. 50 V AC, 2,5 A

Transistor uitgangen:

- uitgang hoog:
typisch 24 V/500 mA
- uitgang laag: < 100 mV
- kortsluitveilig

d Fehlersuche

Fehlfunktion	Ursache	Maßnahme
Schaltet nicht	Versorgungsspannung fehlt (Grüne Leuchtdiode aus)	Versorgung prüfen
	Elektronik defekt	FTL 375 P austauschen
	Kontakte verschweißt (nach einem Kurzschluss)	FTL 375 P austauschen; Sicherung in den Kontaktstromkreis
	Messaufnehmer defekt	Messaufnehmer austauschen
Schaltet falsch	Hakenschalter für Grenzsignal falsch eingestellt	Hakenschalter auf der Platine richtig einstellen (S. 14...17)
Dauernde Störungsmeldung	Unterbrechung oder Kurzschluss der Leitung zum Messaufnehmer	Leitung überprüfen
	Messaufnehmer-Elektronik defekt	Messaufnehmer-Elektronik austauschen
	Fail safe-Messaufnehmer FDL 60/61 mit FEL 67 angeschlossen	Messaufnehmer überprüfen und gegebenenfalls austauschen
Fehlschaltung nach Netzausfall	FEL 57, Verhalten beim Einschalttest (wiederkehrende Prüfung)	Schaltverhalten FEL 57 beachten; Anlagensteuerung nach Netzausfall bis ca. 45 s blockieren

Fault	Reason	Remedy
Does not switch	No power (green LED does not light up)	Check power
	Electronic defect	Replace FTL 375 P
	Contacts welded together (after short-circuit)	Replace FTL 375 P; connect a fuse into contactor circuit
	Measuring transmitter defective	Replace measuring transmitter
Switches incorrectly	Incorrect setting of hook switch for limit signal	Set hook switch to correct setting on pcb (p. 14...17)
Permanent alarm signal	Interrupt or short-circuit line to measuring transmitter	Check line
	Measuring transmitter electronics defective	Replace measuring transmitter electronics
	Fail-safe measuring transmitter FDL 60/61 connected to FEL 67	Check measuring transmitter and replace if necessary
Switches incorrectly after power failure	FEL 57, Behaviour during switch-on test (functional test)	Observe switching behaviour of FEL 57; after a power failure block the system control for up to about 45 s

Défaut	Cause	Mesure
Ne commute pas	Absence tension d'alimentation (diode verte éteinte)	Vérifier l'alimentation
	Electronique défectueuse	Remplacer le FTL 375 P
	Contacts soudés (après un court- circuit)	Remplacer le FTL 375 P; insérer un fusible dans le circuit du contact
	Capteur défectueux	Remplacer le capteur
Mauvaise commutation	Mauvaise réglage du signal de seuil au niveau de l'interrupteur à crochet	Régler correctement le commutateur à crochet sur le pcb (14...17)
Message alarme permanent	Interruption ou court-circuit de la liaison au capteur	Vérifier la liaison
	Electronique du capteur défectueuse	Remplacer l'électronique du capteur
	Transmetteur fail-safe FDL 60/61 raccordé à FEL 67	Vérifier le transmetteur et le remplacer si nécessaire
Mauvaise commutation après coupure	FEL 57, comportement lors du test de mise sous tension (test cyclique)	Tenir compte de la commutation du FEL 57; après une coupure de courant, bloquer la commande de l'installation jusqu'à env. 45 s

Fallo	Causa	Solución
No conmuta	No hay alimentación (el LED verde no está iluminado)	Compruebe la alimentación
	Las electrónicas son defectuosas	Sustituya el FTL 375 P
	Contactos soldados juntos (después del corto circuito)	Sustituya el FTL 375 P; conecte un fusible en el circuito contactor
	Sensor defectuoso	Cambie el sensor
Conmuta incorrectamente	Posición incorrecta del conmutador para la señal de límite	Cambie la posición del conmutador en la electrónica (pág. 14...17)
Aviso de fallo constante	Interrupción o cortocircuito de la conexión con el sensor	Compruebe el cableado
	Electrónicas del transmisor defectuosas	Sustituya la electrónica del transmisor
	Transmisor FDL 60/61 conectado a FEL 67	Compruebe el transmisor y sustitúyalo en caso necesario
Conmuta incorrectamente después de un fallo de alimentación	FEL 57, comportamiento durante la comprobación de conmutación (test de funcionamiento)	Observar el comportamiento de conmutación del FEL 57; tras un fallo de alimentación, bloquear el sistema de control de la planta durante 45 s aprox.

i Individuazione e
eliminazione delle
anomalie

Guasto	Motivo	Rimedio
Non commuta	Manca alimentazione (LED verde spento)	Controllare l'alimentazione
	Elettronica difettosa	Sostituire FTL 375 P
	Contatti saldati insieme (dopo il corto circuito)	Sostituire FTL 375 P; inserire un fusibile nel circuito dei contatti
	Dispositivo guasto	Sostituire il dispositivo
Commuta non correttamente	Errata impostazione	Impostare correttamente (p. 14...17)
Rimane in allarme	Linea interrotta o in corto circuito	Verificare la linea
	Elettronica guasta	Sostituire l'elettronica
	Trasmettitore FDL 60/61 connesso con FEL 67	Verificare il trasmettitore e cambiarlo se necessario
Commutazione non corretta dopo la mancanza alimentazione	FEL 57, Comportamento durante la fase di test all'accensione (test di funzionamento)	Osservare il comportamento di commutazione del FEL 57; dopo il ripristino di una mancanza di alimentazione inibire il controllo dell'impianto per 45 s

Fout	Oorzaak	Maatregel
Schakelt niet	Voeding ontbreekt (groene LED uit)	Voeding testen
	Elektronica defect	FTL 375 P uitwisselen
	Contacten verkleefd (na een kortsluiting)	FTL 375 P uitwisselen; zekering plaatsen in contactcircuit
	Sensor defect	Sensor verwisselen
Schakelt foutief	Niet correcte instelling van de haakchakelaar voor het niveausignaal	Stel haakchakelaar correct in (pag. 14...17)
Continue foutmelding	Onderbreking of signaal kortsluiting van de sensorbekabeling	Kabel testen
	Sensor elektronica defect	Sensor elektronica verwisselen
	Fail-safe transmitter FDL 60/61 verbonden met FEL 67	Check transmitter en indien nodig vervangen
Fout na netuitval	FEL 57, gedrag bij inschakelen na netuitval (periodieke testfunctie)	Schakelgedrag FEL 57 controleren; Installatiebesturing na netuitval ca. 45 s blokkeren

d Ergänzende
Dokumentation

e Supplementary
Documentation

f Documentation
complémentaire

es Documentación
adicional

i Documentazione
supplementare

nl Aanvullende
documentatie

Technische Information, Technical information, Information technique,
Información técnica, Informazioni tecniche, Technische informatie

TI 360F

Sicherheitshinweise, Safety Instructions, Conseils de sécurité,
Instrucciones de seguridad, Istruzioni di sicurezza, Veiligheidsinstructies

XA 147F  II (1) GD, [EEEx ia] IIC

Handbuch zur Funktionalen Sicherheit, Functional Safety Manual
SD 113F

Endress+Hauser Sales Center

AT Tel. (01) 88056-0, Fax (01) 88056-35

BE Tel. (02) 2480600, Fax (02) 2480553

CAN Tel. (905) 6819292, Fax (905) 6819444

CH Tel. (061) 7157575, Fax (061) 7111650

DE Tel. (07621) 97501, Fax (07621) 975555

DK Tel. (70) 131132, Fax (70) 132133

ES Tel. (93) 4803366, Fax (93) 4733839

FR Tel. (389) 696768, Fax (389) 694802

GB Tel. (0161) 2865000, Fax (0161) 9981841

HK Tel. 25283120, Fax 28654171

IT Tel. (02) 92192-1, Fax (02) 92192-362

JP Tel. (0422) 540613, Fax (0422) 550275

MAL Tel. (03) 7334848, Fax (03) 7338800

NO Tel. (032) 859850, Fax (032) 859851

NL Tel. (035) 6958611, Fax (035) 6958825

SE Tel. (08) 55511600, Fax (08) 55511655

SF Tel. (09) 8676740, Fax (09) 86767440

SGP Tel. 5668222, Fax 5666848

THA Tel. (2) 9967811-20, Fax (2) 9967810

USA Tel. (317) 5357138, Fax (317) 5358498

ZA Tel. (011) 2628000, Fax(011) 262806

INTERNATIONAL Tel. + Fax: see DE
<http://www.endress.com> 11.00/PTS-D



52010892