

Technical manual BA 0210



Precont MT – Precont KT – Precont CT Pressure transmitter

for supervision of absolute and relative pressure
in gases, vapors, liquids and dusts

Pressure ranges 0...0,1 bar to 0...1000 bar / -0,1...0/+0,1 bar / -1...0/+1 bar

Ceramic or metallic membrane with various applications

Suitable for wide process temperature range from – 40 °C to +100 °C

ATEX II 1 G Ex ia IIC T6

Certification for the use in explosion hazardous areas

Shortest response time and excellent accuracy up to $\leq 0,1\%$

Integrated evaluation electronic

- in 2-wire-technology with current signal 4...20 mA
- in 3-wire-technology with voltage signal 0...10 V

ACS-CONTROL-SYSTEM
know how mit system



Lauterbachstr. 57 – 84307 Eggenfelden – Germany
Tel: +49 8721/9668-0 – Fax: +49 8721/9668-30
info@acs-controlsystem.de – www.acs-controlsystem.de

Index

Application description	3
Function	3
Variant differences / permissible overload resp. burst pressure	4
Safety notes	5
Safety notes 	5
Installation	6
Maintenance	6
Repair	6
Electrical connection – terminal assignment	7
Electrical connection – non-explosive hazardous area	8
Electrical connection – explosive hazardous area	9
Technical data	10 / 11
Dimension drawings	12
Order code overview Precont MT	13
Order code overview Precont KT	14
Order code overview Precont CT	15

Application description

The devices of the series **Precont MT – Precont KT – Precont CT** with integrated analogue evaluation electronic are compact pressure transmitter for continuous measuring of pressures from –1 up to 1000 bar in gases, vapors, liquids and dusts within closed container or pipes, also in explosive hazardous areas, at process temperatures from – 40°C to +100°C.

The use of a capacitive measuring sensor with ceramic membrane or of a strain gauge with alternatively ceramic or metallic membrane and the respective corresponding excellent characteristics, allows the use in nearly all fields of industry.

Function description

The pressure transmitter **Precont MT – Precont KT – Precont CT** is mounted in the wall of the pressure container or of the pipe.

Characteristics of the metallic strain gauge measuring membrane – Precont MT

The system pressure is applied to the metallic membrane and causes there a deflection of the polysilicone resp. thin film strain gauge at the back side of the membrane.

At measuring ranges of 0...25 bar and smaller, the pressure is transmitted by a pressure transmitting liquid to the polysilicone strain gauge.

The metallic membrane offers excellent characteristics like high pressure and pressure blow strength up to five times the nominal pressure, vacuum resistance, good reproducibility and hysteresis and also good long term stability and a low temperature influence.

Characteristics of the dry ceramic strain gauge measuring membrane – Precont KT

The system pressure is applied to the ceramic membrane and causes there a deflection of the thick film strain gauge at the back side of the membrane.

The ceramic membrane offers excellent characteristics like high pressure and pressure blow strength up to four times the nominal pressure, vacuum resistance, very high resistance against chemicals, corrosion and abrasion, very good insensitiveness against temperature shocks, high accuracy and reproducibility, good long term stability and a low temperature influence.

Characteristics of the dry ceramic strain capacitive measuring membrane – Precont CT

The system pressure is applied to the ceramic membrane and causes there a variation of the capacity at the back side of the membrane.

The ceramic membrane offers excellent characteristics like highest pressure and pressure blow strength up to forty times the nominal pressure, vacuum resistance, very high resistance against chemicals, corrosion and abrasion as well as very good insensitiveness against temperature shocks, highest accuracy and reproducibility, good long term stability and a very low temperature influence.

Signal processing

The pressure dependent variation of capacity resp. the variation of the strain gauge output voltage is converted into an electrical signal and converted by the integrated evaluation electronic into a current signal 4...20 mA resp. voltage signal 0...10 V.

Precont MT – Precont KT – Precont CT

Variant differences / permissible overload resp. burst pressure			
	Precont MT	Precont KT	Precont CT
measuring system	metallic strain gauge	ceramic strain gauge	ceramic capacitive membrane
accuracy	≤ 0,5 % FS ²⁾	≤ 0,5 % FS ²⁾	≤ 0,1 % / 0,25 % FS ²⁾
maximum torque strength	50 Nm	50 Nm	20 Nm
pressure range	overload / burst pressure	burst pressure	burst pressure
-0,1...+0,1 bar	not available	not available	4 bar
-1...+1 bar	17 / 20,5 bar	not available	10 bar
0...0,1 bar	not available	not available	4 bar
0...0,2 bar	not available	not available	4 bar
0...0,4 bar	not available	not available	4 bar
0...0,6 bar	not available	not available	10 bar
0...1 bar	10 / 12 bar	4 bar	10 bar
0...1,6 bar	10 / 12 bar	4 bar	15 bar
0...2,5 bar	10 / 12 bar	4 bar	25 bar
0...4 bar	17 / 20,5 bar	10 bar	25 bar
0...6 bar	35 / 42 bar	10 bar	40 bar
0...10 bar	35 / 42 bar	20 bar	40 bar
0...16 bar	80 / 96 bar	40 bar	40 bar
0...25 bar	80 / 96 bar	40 bar	not available
0...40 bar	80 / 400 bar	100 bar	not available
0...60 bar	80 / 400 bar	100 bar	not available
0...100 bar	200 / 800 bar	200 bar	not available
0...160 bar	320 / 1000 bar	400 bar	not available
0...250 bar	500 / 1200 bar	400 bar	not available
0...320 bar	800 / 1700 ¹⁾ bar	800 bar	not available
0...400 bar	800 / 1700 ¹⁾ bar	800 bar	not available
0...600 bar	1200 / 2400 ¹⁾ bar	> 800 bar	not available
0...1000 bar	1500 / 3000 bar	not available	not available

¹⁾ At front flush metallic membrane: The value in the table is only valid at insulation with ring gasket below the hexagon. Otherwise the value of max. 1500 bar is valid.

²⁾ Referring to nominal measuring span resp. full scale (FS)

Safety notes



Each person that is engaged with inauguration and operation of this device, must have read and understood this technical manual and especially the safety notes.

Installation, electrical connection, inauguration and operation of the device must be made by a qualified employee according to the informations in this technical manual and the relevant standards and rules.

The device may only be used within the permitted operation limits that are listed in this technical manual. Every use besides these limits as agreed can lead to serious dangers.

The materials of the device must be chosen resp. checked for suitability to the respective application requirements (contacting substances, process temperature). An unsuitable material can lead to damage, abnormal behavior or destruction of the device and to the resulting dangers.

The sensors may not used as sole device for prevention of dangerous conditions in machines and plants.

This measuring device meets article 3 (3) of the EC directive 97/23/EC (pressure equipment device directive) and is designed and produced in good engineer practice.

The device meets the legal requirements of all relevant EC directives.  0158



Safety notes for electrical operating supplies for explosive hazardous areas

If a device is installed and operated in explosive hazardous areas, the general Ex construction standards (EN/IEC 60079-14, VDE 0165), these safety notes and the enclosed EC conformity certificate must be observed.

The installation of explosive hazardous systems must be carried out principally by specialist staff.

The device meets the classification:

II 1 G Ex ia IIC T4/T6 resp. II 1/2 G Ex ia IIC T4/T6

Ta = - 20...+60°C/+50°C

II 2 G Ex ib IIC T4/T6

Ta = - 40...+85°C/+50°C

The devices are conceived for measuring of pressures in explosive hazardous areas.

The measured medium may also be combustible liquids, gases, fogs or vapors.

The permitted operating temperatures and pressures are type and variant dependent and can be found in this technical manual.

For applications, which require devices of category 1/2 or category 1, the process pressure and temperature range of the media has to be between 0,8 bar and 1,1 bar and between -20 °C and 60 °C.

The PA connection in the connector resp. the cable shield resp. the process connection must be connected with the potential compensation of the explosion hazardous area.

At variants of the devices with chargeable plastic parts (e.g. cable resp. connection housing), a warning marking points out to the safety measures, that must be applied because of the electrostatic charging in operation and especially in the case of maintenance activities.

avoid friction - no dry cleaning - no assembling in pneumatic conveying stream

Installation

The installation of the device at locations where high pressure blows can occur should be avoided.

Drive the system pressure free prior installation resp. deinstallation of the sensor.

The tightening of the process connection with screw-in thread may only be done at the hexagon by a suitable spanner. The maximum permitted torque strength for the types Precont MT – Precont KT is 50 Nm, however for the type Precont CT maximum 20 Nm. The screw in of the process connection by using the housing tube, the connection plug resp. the connection cable is not permitted.

Avoid the pollution of the pressure compensation hole at the version with plug M12x1 resp. of the pressure compensation element at the version with plug EN 175-301-803 (DIN 43650) resp. of the pressure compensation capillary at the version with connected cable. The hindrance of the pressure compensation can lead to faulty measuring results. The pressure compensation is made at the version:

- S – plug acc. to EN 175-301-803-C (DIN 43650-C) by the plug socket
- T – plug acc. to EN 175-301-803-A (DIN 43650-A) by the plug socket
- V – plug M12x1 by the drill hole besides the plug
- K – connected cable by the capillary inside the cable

At the version with connected cable, the environmental air pressure is lead to the measuring membrane by an integrated pressure compensation capillary. This capillary may not be folded or sealed. To avoid faulting, a micro air filter is placed at the end of the capillary. In the case of an application conditioned cutting of the connected cable there must be especially paid attention that this micro air filter will be replaced to the end of the capillary after cutting.

The correct function of the device within the specific technical data can only be guaranteed, if the permitted temperature in the area of the housing tube from – 40°C to +85°C (– 40°C to +70°C at version – electrical connection type K – connected cable) will not be exceeded. This can be achieved by isolation of the medium carrying part of the plant or by other constructive measures to reduce the transferring of an extreme temperature to the housing tube.

Maintenance

The devices of the series Precont MT – Precont KT – Precont CT are free of maintenance.

Special substances can lead to solid coatings on the membrane.

Such depositions can lead to faulty measurement results of the pressure sensor.

In the case of coat forming liquids the membrane must be regularly cleaned e.g. with clear water. Don't use sharp tools or aggressive chemicals for cleaning.

Repair

A repair may only be carried out by the manufacturer.

If the device must be sent back for repair, the following informations must be enclosed:

- An exact description of the application.
- The chemical and physical characteristics of the product.
- A short description of the occurred error.

Before returning the device for repair, the following measures must be proceeded:

- All stick product residues must be removed. This is especially important, if the product is unhealthily, e.g. caustic, toxic, carcinogenic, radioactive etc.
- A returning must be refrained, if it is not possible by 100% to remove the unhealthily product completely, because e.g. it is penetrate into cracks or is diffused through plastic.

Electrical connection

The electrical connection of the device must be carried out according to the respective country specific standards.

Incorrect installation or adjustment could cause applicationally conditioned risks.

Use only shielded signal and measurement wires and install these wires separated from power leading wires. Connect the cable shield only at one side to earth, ideally at the installation place of the device.

The device must be grounded. The metallic parts of the device (process connection, housing tube) are electrically connected with the terminal PE of the plug EN 175-301-803-A/-C (DIN 43650-A/-C), with the socket of the plug M12x1 or with the cable shield of the version with connected cable.

Due to this the earth connection can be carried out by the process connection.

The voltage applied to the terminal contacts may not exceed 32 V to avoid damage of the electronic. All connections are polarity protected.

Terminal assignment

plug (socket)
EN 175-301-803 (DIN 43650)
style A style C

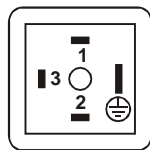
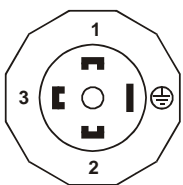

plug (socket)
M12x1

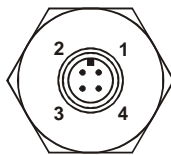

connected cable

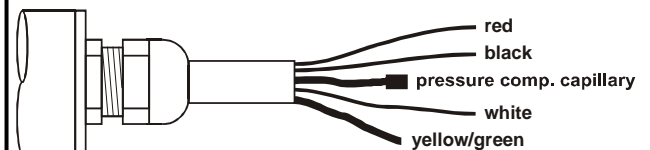

Terminal assignment 2-wire-technology / signal 4...20 mA

Pin 1 signal +
Pin 2 signal -
Pin 3 n. c.

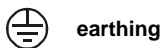

Pin 1 signal +
Pin 2 signal -
Pin 3 n. c.

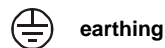

Pin 1 signal +
Pin 2 n. c.
Pin 3 signal -
Pin 4 n. c.

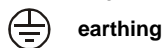

red
black
white

signal +
signal -
not available

yellow/green earthing

Terminal assignment 3-wire-technologie / signal 0...10 V

Pin 1 supply +
Pin 2 supply -
Pin 3 output +

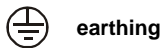

Pin 1 supply +
Pin 2 supply -
Pin 3 output +

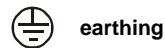

Pin 1 supply +
Pin 2 n. c.
Pin 3 supply -
Pin 4 output +

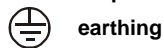

red
black
white

supply +
supply -
output +

yellow/green earthing

Electrical connection – non explosive hazardous area

2-wire-technology / signal 4...20 mA

connected cable

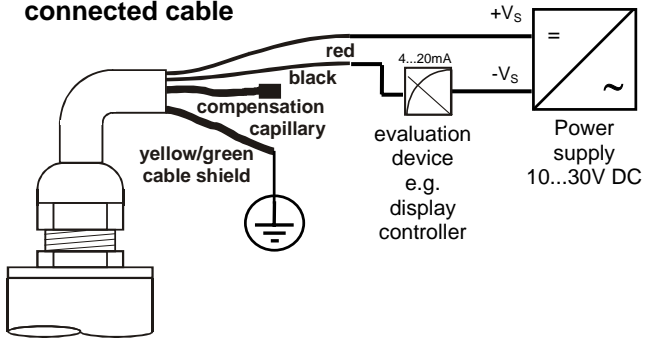

3-wire-technology / signal 0...10 V

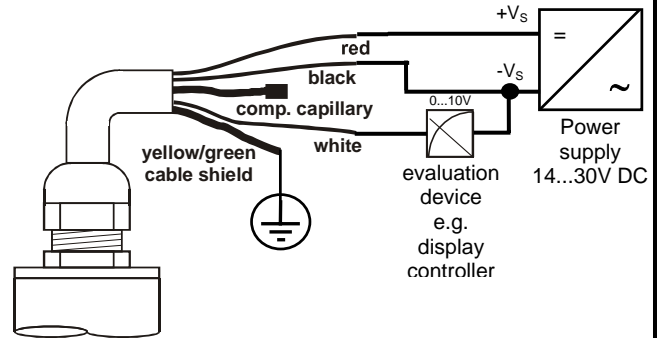

plug EN 175-301-803 (DIN 43650)

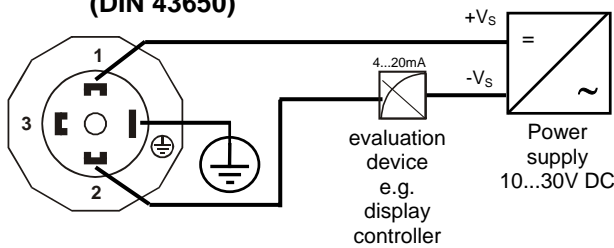

plug M12x1

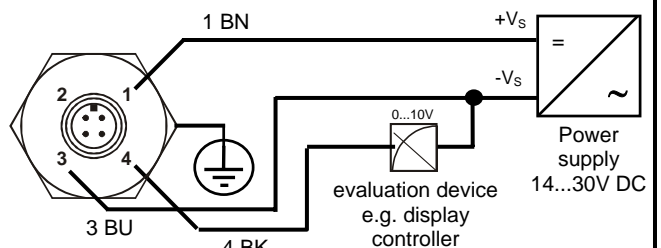
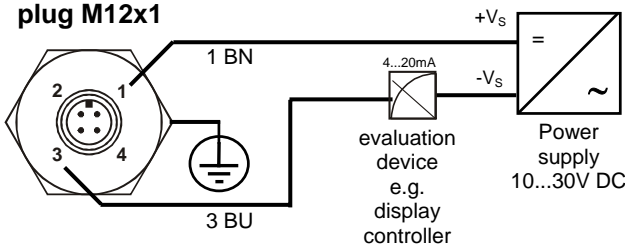

Conductor color standard connection cable M12: BN = brown, WH = white, BK = black, BU = blue
The connection cable is not enclosed in the delivery contents.

Electrical connection – explosive hazardous area

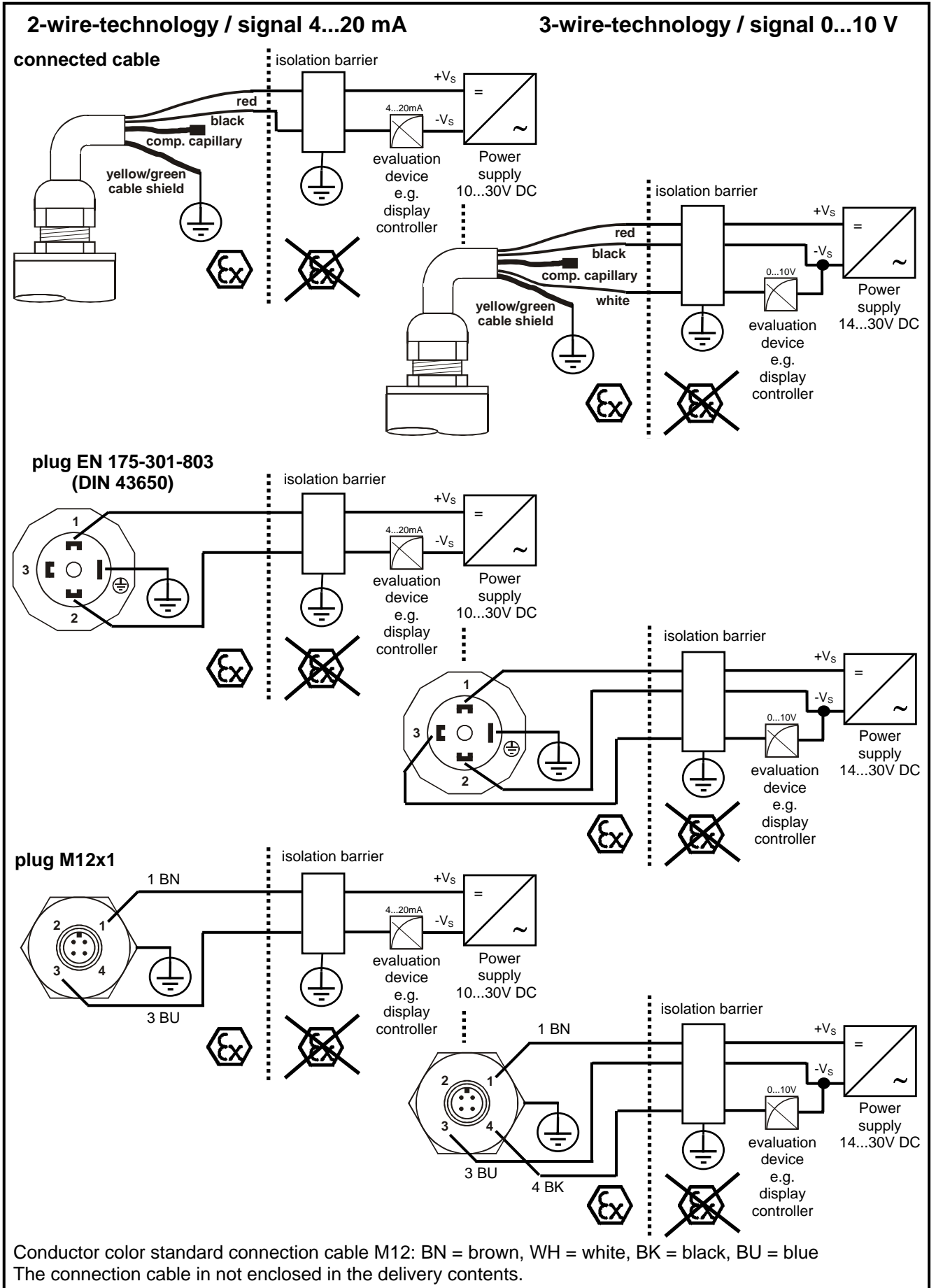

Technical data

Auxiliary supply

Supply voltage:	2-wire 4...20 mA	10..30 V DC	reverse polarity protected
	3-wire 0...10 V	14..30 V DC	reverse polarity protected
Ripple voltage:	$\leq 2 V_{PP}$	condition:	within the permitted supply voltage range
Supply current:	2-wire 4...20 mA	≤ 30 mA	
	3-wire 0...10 V	≤ 6 mA	

Analogue output 4...20 mA

Signal range:	linear characteristic from ≤ 3 mA resp. ≥ 22 mA, max. 30 mA
Permitted load:	$R_L \leq (V_{S \text{ act.}} - 10 \text{ V}) / 20 \text{ mA}$
Minimum delay time:	Precont MT / KT ≤ 2 ms Precont CT ≤ 6 ms
Influence of supply voltage:	$\leq \pm 0,04\% \text{ FS}^2) / 10 \text{ V}$

Analogue output 0...10 V

Signal range:	linear characteristic from 0...11 V, max. $V_{S \text{ act.}} - 1,5 \text{ V}$
Permitted load:	$R_L \geq 5000 \Omega$, equals 2mA at 10 V, current limited
Minimum delay time:	Precont MT / KT ≤ 2 ms Precont CT ≤ 6 ms
Influence of supply voltage:	$\leq \pm 0,04\% \text{ FS}^2) / 10 \text{ V}$

Measuring accuracy

Characteristic deviation ^{3) 5) 12)} :	Precont MT / KT $\leq \pm 0,5\% \text{ FS}^2)$ Precont CT $\leq \pm 0,1\% / 0,25\% \text{ FS}^2)$
Nonlinearity ¹²⁾ :	Precont MT / KT $\leq \pm 0,3\% \text{ FS}^2)$ Precont CT $\leq \pm 0,1\% / 0,25\% \text{ FS}^2)$
Hysteresis ¹²⁾ :	Precont MT / KT $\leq \pm 0,1\% \text{ FS}^2)$ Precont CT negligible
Long term drift ¹²⁾ :	$\leq \pm 0,15\% \text{ FS}^2) / \text{year}$ not cumulative
Temperature deviation ¹²⁾ :	Precont MT $T_k^{4)}$ Zero $\leq \pm 0,2\% \text{ FS}^2) / 10 \text{ K}$ $T_k^{4)}$ Span $\leq \pm 0,2\% \text{ FS}^2) / 10 \text{ K}$ Precont MT $T_k^{4)}$ Zero $\leq \pm 0,2\% \text{ FS}^2) / 10 \text{ K} (0...+80^\circ\text{C})$ $T_k^{4)}$ Span $\leq \pm 0,2\% \text{ FS}^2) / 10 \text{ K} (0...+80^\circ\text{C})$ besides 0...+80°C with factor 2 for T_k Precont KT $T_k^{4)}$ Zero $\leq \pm 0,1\% \text{ FS}^2) / 10 \text{ K}$ $T_k^{4)}$ Span $\leq \pm 0,1\% \text{ FS}^2) / 10 \text{ K}$ Precont CT $T_k^{4)}$ Zero $\leq \pm 0,15\% \text{ FS}^2) / 10 \text{ K}$, max. 1 % $T_k^{4)}$ Span $\leq \pm 0,15\% \text{ FS}^2) / 10 \text{ K}$, max. 1 %

²⁾ Referring to nominal measuring span resp. full scale (FS)

³⁾ Nonlinearity + Hysteresis + Reproducibility

⁴⁾ T_k = Temperature coefficient

⁵⁾ At limit value adjustment acc. to EN/IEC 60770-1

¹²⁾ Higher values for special measuring range

Precont MT – Precont KT – Precont CT

Technical data

Materials

Membrane: (medium contact)	Precont MT	<i>front flush</i> $\geq 40 \text{ bar}$ $< 40 \text{ bar}$	steel 1.4571 (AISI 316Ti) steel 1.4571 (AISI 316Ti) steel 1.4542 (AISI 630) / 1.4534
	Precont KT	ceramic AL ₂ O ₃	96%
	Precont CT	ceramic AL ₂ O ₃	96%
Process connection: (medium contact)	Precont MT	steel 1.4571 (AISI 316Ti)	
	Precont KT	steel 1.4404 (AISI 316L) / 1.4571 (AISI 316Ti)	
	Precont CT	steel 1.4404 (AISI 316L) / 1.4571 (AISI 316Ti)	
Housing tube:	CrNi-steel		
Device plug:	EN 175-301-803-A/-C (formerly DIN 43650-A/-C): housing PA polyamide, contacts tinned, gasket NBR M12x1: socket CrNi-steel, insert PUR, contacts gold-plated		
Connected cable:	cable:	cable sheath PE polyethylene	
	cable gland:	housing PA polyamide, gasket CR / NBR	
Pressure compens. element:	filter membrane PES resp. micro air filter PTFE		
Gaskets:	medium contact	→ FPM – fluorelastomere (Viton®) EPDM – etylene-propylene-dienmonomere NBR – nitril-butadien-rubber	
	others	→ FPM – fluorelastomere (Viton®)	

Environmental conditions

Environmental temperature:	– 40°C...+85°C – 40°C...+70°C at version electrical connection type K		
Process temperatures:	– 40°C...+100°C (-30°C with gasket NBR / -25°C with gasket FPM)		
Process pressure ranges:	-1 bar ...1000 bar, relative or absolute		
Pressure transmitting liquid:	synthetic oil	only Precont MT, for ranges $\leq 0...25 \text{ bar}$	
Overload strength:	depends on membrane resp. measuring range, see table overload / burst pressure		
Vacuum strength:	0 mbar _{abs}		
Weight:	0,25 kg	Typ K:	0,25 kg + (cable length x 0,035 kg/m)
Torque strength:	Precont MT / KT	$\leq 50 \text{ Nm}$	
	Precont CT	$\leq 20 \text{ Nm}$	
Protection classification	<i>version plug acc. to EN 175-301-803 (formerly DIN 43650)</i> IP65 EN/IEC 60529 <i>version plug M12x1 and version connected cable</i> IP68 EN/IEC 60529 up to 1 mWs		
Climatic classification:	4K4H	EN/IEC 60721-3-4	
Shock classification:	50 g	EN/IEC 60068-2-27	(11 ms)
Vibration classification:	20 g	EN/IEC 60068-2-6	(10 - 2000 Hz)
EM – compatibility:	emission	EN/IEC 61326	operation device class B
	immunity	EN/IEC 61326	industrial range
Reference conditions:	EN/IEC 60770-1 resp. EN/IEC 61003-1 T = 25 °C, relative humidity 45...75 %, environmental air pressure 860...1060 kPa		

Precont MT – Precont KT – Precont CT

Style housing

plug EN 175-301-803 (DIN 43650)
style A

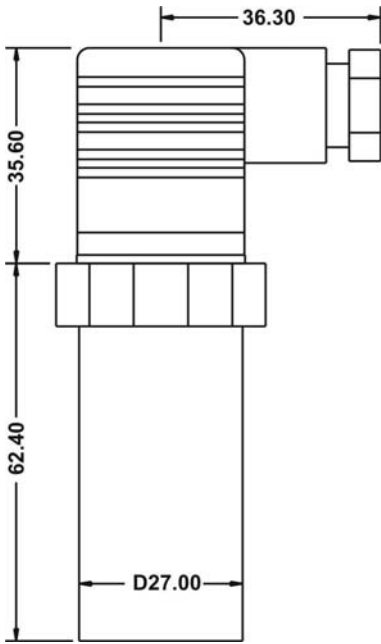

style C

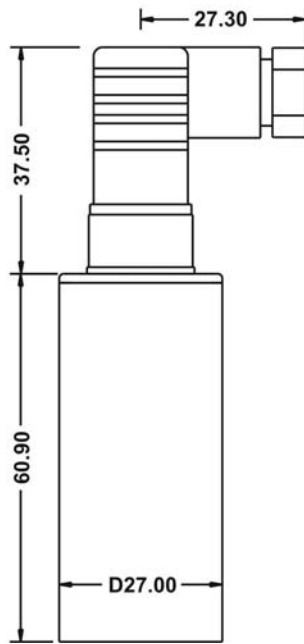

plug
M12x1

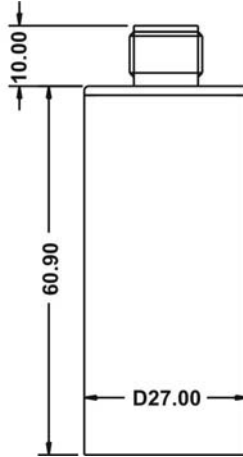

connected cable

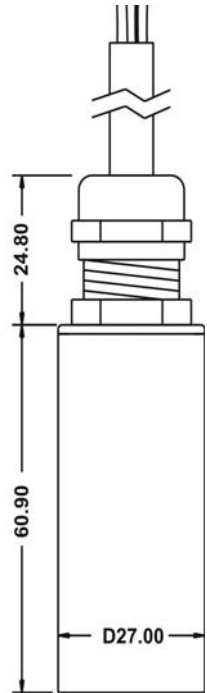

Precont MT0

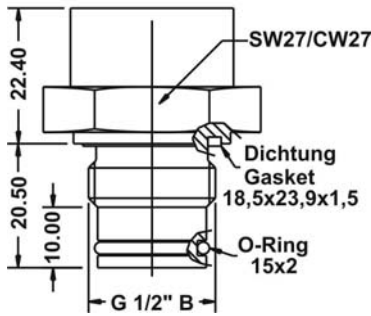

Precont MT1

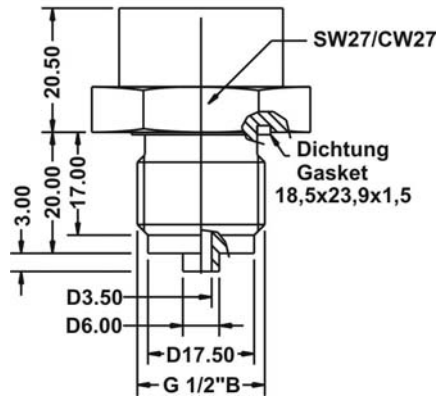

Precont MT6

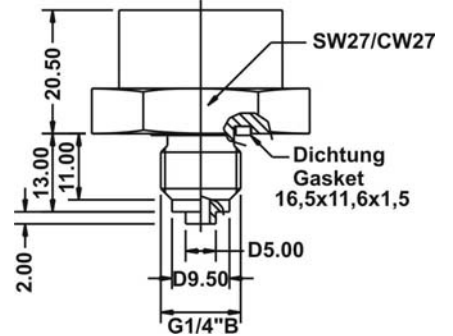

Precont KT1

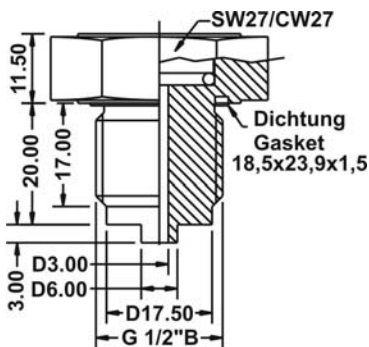

Precont KT2

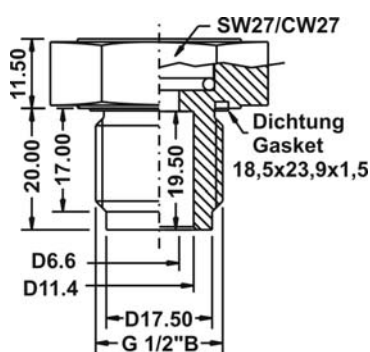

Precont KT3

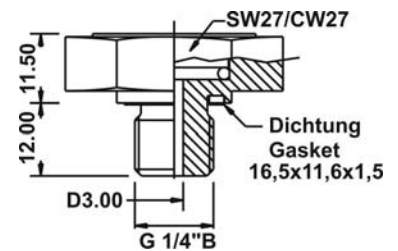

Precont KT4

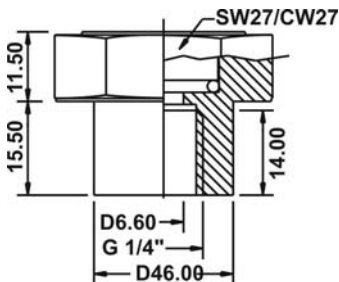

Precont CT0

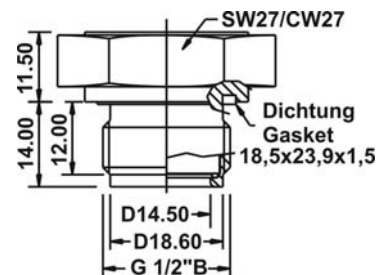

Precont MT – Precont KT – Precont CT

Precont MT Analogue pressure transmitter with metallic strain gauge membrane up to 1000 bar
analogue output 4...20mA or 0...10V

Type:

- Standard
Ex ATEX II 1 G Ex ia IIC T6

Measuring membrane (medium contact):

MT Metallic strain gauge membrane process connection type 0 steel 1.4571 (AISI 316Ti)
measuring range ≥ 40 bar steel 1.4571 (AISI 316Ti)
measuring range < 40 bar steel 1.4542 (AISI 630) / 1.4534

Process connection:

0 G ½" B ISO 228-1 front flush, with radial O-ring, up to 600 bar
1 G ½" B ISO 228-1 EN 837-3 manometer (formerly DIN 16288)
6 G ¼" B ISO 228-1 EN 837-3 manometer (formerly DIN 16288)
Y others on request

Gaskets (medium contact):

0 NBR nitril-butadien-rubber
1 FPM fluorelastomere (Viton®)
3 EPDM etylene-propylene-dienmonomere for food applications

Material process connection (medium contact):

V Steel 1.4571 (AISI 316Ti)

Material connection housing:

C CrNi-steel

Measuring range:

05 0...1 bar
06 0...1,6 bar
07 0...2,5 bar
08 0...4 bar
09 0...6 bar
10 0...10 bar
11 0...16 bar
12 0...25 bar
13 0...40 bar
14 0...60 bar
19 0...100 bar
20 0...160 bar
21 0...250 bar
22 0...320 bar
23 0...400 bar
24 0...600 bar
25 0...1000 bar not for process connection type 0 – G ½" B front flush
17 -1...+1bar
YY special measuring range separate spec. necessary

Electronic - output:

A 2-wire-technology signal 4...20 mA
B 3-wire-technology signal 0...10 V

Process temperature:

0 Standard -40°C to +100°C

Pressure type:

R Relative pressure
A Absolute pressure not for measuring ranges ≥ 40 bar

Accuracy measuring system ¹⁾:

4 0,5 %

Electrical connection:

S Plug acc. to EN 175-301-803-C (formerly DIN 43650-C)
T Plug acc. to EN 175-301-803-A (formerly DIN 43650-A)
V Plug M12x1
K Connected cable, from 1,5m

Precont _ MT _ _ V C _ _ 0 _ 4 _

Installation material and connection cable are not enclosed in the delivery contents.

¹⁾ Higher values for special measuring range

Precont MT – Precont KT – Precont CT

Precont KT Analogue pressure transmitter with ceramic strain gauge membrane up to 600 bar
analogue output 4...20mA or 0...10V

Type:

- Standard
- Ex ATEX II 1 G Ex ia IIC T6

Measuring membrane (medium contact):

KT Ceramic strain gauge membrane ceramic AL₂O₃ 96%

Process connection:

- 1 G ½" B ISO 228-1 EN 837-3 manometer (formerly DIN 16288)
- 2 G ½" B ISO 228-1 internal drill 11,4mm
- 3 G ¼" B ISO 228-1 DIN 3852-11-E
- 4 G ¼" ISO 228-1 internal thread
- 8 ¼" NPT ANSI B 1.20.1
- Y others on request separate spec. necessary

Gaskets (mediumberührend):

- 1 FPM fluorelastomere (Viton®)
- 3 EPDM etylene-propylene-dienmonomere for food applications

Material process connection (medium contact):

V Steel 1.4404 (AISI 316L) / 1.4571 (AISI 316Ti)

Material connection housing:

C CrNi-steel

Measuring range:

- 05 0...1 bar
- 06 0...1,6 bar
- 07 0...2,5 bar
- 08 0...4 bar
- 09 0...6 bar
- 10 0...10 bar
- 11 0...16 bar
- 12 0...25 bar
- 13 0...40 bar
- 14 0...60 bar
- 19 0...100 bar
- 20 0...160 bar
- 21 0...250 bar
- 22 0...320 bar
- 23 0...400 bar
- 24 0...600 bar
- YY special measuring range separate spec. necessary

Electronic - output:

- A 2-wire-technology signal 4...20 mA
- B 3-wire-technology signal 0...10 V

Process temperature:

- 0 Standard -40°C to +100°C

Pressure type:

- R Relative pressure
- A Absolute pressure

Accuracy measuring system ¹⁾:

- 4 0,5 %

Electrical connection:

- S Plug acc. to EN 175-301-803-C (formerly DIN 43650-C)
- T Plug acc. to EN 175-301-803-A (formerly DIN 43650-A)
- V Plug M12x1
- K Connected cable, from 1,5m

Precont _ KT _ _ V C _ _ 0 _ 4 _

Installation material and connection cable are not enclosed in the delivery contents.

¹⁾ Higher values for special measuring range

Precont MT – Precont KT – Precont CT

Precont CT Analogue pressure transmitter with ceramic capacitive membrane up to 16 bar
analogue output 4...20mA or 0...10V

Type:

- Standard
Ex ATEX II 1 G Ex ia IIC T6

Measuring membrane (medium contact):

CT Ceramic capacitive membrane ceramic AL₂O₃ 96%

Process connection:

0 G ½" B ISO 228-1 DIN 3852-11-E front flush
Y others on request

Gaskets (medium contact):

1 FPM fluorelastomere (Viton®)
3 EPDM etylene-propylene-dienmonomere for food applications

Material process connection (medium contact):

V Steel 1.4404 (AISI 316L) / 1.4571 (AISI 316Ti)

Material connection housing:

C CrNi-steel

Measuring range:

01 0...0,1 bar
02 0...0,2 bar
03 0...0,4 bar
04 0...0,6 bar
05 0...1 bar
06 0...1,6 bar
07 0...2,5 bar
08 0...4 bar
09 0...6 bar
10 0...10 bar
11 0...16 bar
17 -0,1...+0,1bar
18 -1...+1 bar
YY special measuring range separate spec. necessary

Electronic - output:

A 2-wire-technology signal 4...20 mA
B 3-wire-technology signal 0...10 V

Process temperature:

0 Standard -40°C to +100°C

Pressure type:

R Relative pressure
A Absolute pressure

Accuracy measuring system¹⁾:

0 0,1 %, with linearization protocol
2 0,25 %

Electrical connection:

S Plug acc. to EN 175-301-803-C (formerly DIN 43650-C)
T Plug acc. to EN 175-301-803-A (formerly DIN 43650-A)
V Plug M12x1
K Connected cable, from 1,5m

Precont _ CT _ 1 V C _ _ 0 _ _ _

Installation material and connection cable are not enclosed in the delivery contents.

¹⁾ Higher values for special measuring range