



fill level



water level



pressure



temperature



flow



visualization



signal converter



sensoric



## Precont PLM

### Pressure switch

*Monitoring of absolute or relative pressure in gases, vapors, liquids and dust*

Technical manual  
08.11



### Main features

Finely graded pressure measuring

- Measuring ranges from -1 to 25 bar, gauge
- Measuring ranges from 0 to 25 bar, absolute
- Measuring spans from 0,1 to 25 bar

Metallic flush-mounted EHEDG conformal membrane for hygienic applications

Process temperature range from - 20 °C to +150 °C

Accuracy up to  $\leq 0,5\%$

Integrated evaluation electronic

- 2x PNP switch output
- 3-wire with current signal 4...20 mA

Enclosure and display rotatable for optimal operability in each installation position

Hygienic optimized design with closed operation surface

---

You have purchased a high-grade and modern measuring device of ACS-CONTROL-SYSTEM GmbH.

We want to give thanks for your purchase and for your confidence to us.

The actual technical manual includes instructions for installation, electrical connection and inauguration, as well as the technical data of the device.

Modifications, that answer the purpose of the technical progress, are reserved by ACS-CONTROL-SYSTEM GmbH without prior notice.

If a question occurs, that can't be answered by the listed informations, please call on our technicians team in Eggenfelden Tel: +49 8721/ 9668-0 or [info@acs-controlsystem.de](mailto:info@acs-controlsystem.de)

All rights reserved

---

# Index

<b>Application</b> .....		<b>4</b>
<b>Function</b> .....		<b>4</b>
<b>Safety notes</b> .....		<b>5</b>
<b>Installation</b> .....		<b>6</b>
Installation place	6	
Process and environmental temperature	6	
Installation notes	6	
Air pressure compensation	6	
<b>Electrical connection</b> .....		<b>7</b>
Potential equalization - earthing	8	
Connection cable	8	
Supply voltage	8	
Load resistor	9	
Switch output	9	
Connection scheme	9	
<b>Operation</b> .....		<b>10</b>
Operation and display parts	10	
Function modes	11	
Switch output S1 / S2	11	
Signal output	14	
Menu structure	15	
Parameter overview	18	
Error indication at operation	22	
<b>Maintenance</b> .....		<b>23</b>
<b>Repair</b> .....		<b>24</b>
<b>Technical Data</b> .....		<b>25</b>
Auxiliary power supply	25	
Output Switch output	25	
Output Signal 4...20mA	25	
Measuring accuracy	25	
Mounting position	26	
Process conditions	26	
Environmental conditions	26	
Materials - process wetted	26	
Materials - not process wetted	27	
<b>Dimension drawings</b> .....		<b>28</b>
Terminal enclosure	28	
Process connection	29	
<b>Order Code</b> .....		<b>31</b>

---

## Application

The device is an electronic pressure switch for monitoring, control as well as continuous measurement of relative or gauge pressures in gases, vapors, liquids and dusts within closed container or pipes.

The use of a piezoresistive measuring sensor with EHEDG conformal metallic membrane and the corresponding excellent characteristics, allows the use especially in hygienic applications.

## Function

The device is mounted in the wall of the pressure container or of the pipe.

The system pressure is applied to the metallic membrane and causes there a variation of the resistance of the strain gage at the back side of the membrane.

The metallic membrane offers excellent characteristics like high pressure and pressure blow strength, vacuum resistance, high accuracy and reproducibility, good long term stability and a low temperature influence.

A FDA-listed pressure transmitting liquid is used for the transmission of the pressure from the membrane to the strain gage.

The pressure signal, that is transmitted by the membrane to the sensor is converted into an electrical signal and processed by the integrated evaluation electronic according to the respective preferences.

The measuring value is diagrammed at the display.

The measuring value is monitored by two PNP switch outputs for exceedance of limit values and converted into a continuous current signal 4...20 mA.

By 3 sensor keys and the four-digit LED display all settings for the PNP switching outputs, the display and also the analogue output can be set resp. adjusted.

---

## Safety notes

Each person that is engaged with inauguration and operation of this device, must have read and understood this technical manual and especially the safety notes.

Installation, electrical connection, inauguration and operation of the device must be made by a qualified employee according to the informations in this technical manual and the relevant standards and rules.

The device may only be used within the permitted operation limits that are listed in this technical manual.

Every use besides these limits as agreed can lead to serious dangers.

The materials of the device must be chosen resp. checked for compatibility with the respective application requirements (contacting materials, process temperature). An unsuitable material can lead to damage, abnormal behavior or destruction of the device and to the resulting dangers.

The sensors may not be used as sole device for prevention of dangerous conditions in machines and plants.

This measuring device meets article 3 (3) of the EC directive 97/23/EC (pressure equipment device directive) and is designed and produced in good engineer practice.

The device meets the legal requirements of all relevant EC directives. 

Using the device in a manner that does not fall within the scope of its intended use, disregarding this instruction, using under-qualified personnel, or making unauthorized alterations releases the manufacturer from liability for any resulting damage. This renders the manufacturer's warranty null and void.

---

## Installation

The correct function of the device within the specific technical data can only be guaranteed, if the permitted process and environmental temperatures (see chapter „Technical data“) will not be exceeded.

### Installation place

The installation of the device at locations where high pressure blows can occur should be avoided. At a pressure measurement in gases, the device should be installed above the tapping point, so that the condensate can flow into the process.

At a pressure measurement in steams, the device should be installed after a siphon and a shut-off device below the tapping point. The siphon reduces the temperature to almost ambient temperature. Fill the siphon with fluid before commissioning.

At a pressure measurement in liquids, the device should be installed after a shut-off device below or at the same level as the tapping point.

At a filling level measurement in liquids, the device should be installed below the lowest measuring point. Do not mount the device in the fill flow, in the suction area of a pump, in the tank outlet or at a point in the container which could be affected by pressure pulses from an agitator. Calibration and functional test can be carried out more easily if you mount the device after a shut-off device.

The installation position has influence on the measuring result of the kind of a zero value shift because of the deadweight of the measuring membrane. The correction of this deviation at the device is possible.

### Process and environmental temperature

The installation of the device should be made if possible at temperature calmed places to get a reliable measuring result. Strong temperature steps, e.g. at filling of a hot liquid into a cold system, can produce a short-time higher measuring signal deviation.

Temperature compensation takes effect after several minutes. Internal temperature compensation is faster the smaller the jump in temperature and the longer the time interval involved.

At a large amplification of the measuring signal this deviation will be also amplified accordingly.

The deviation will be completely neutralized after the adaptation of the measuring membrane to the temperature.

At a step from +20°C ...+80°C this neutralization can wile up to 3 minutes.

The use of a measuring system with process diaphragm seal can cause an essential improvement.

At high process temperatures a heat transfer to the terminal housing can be reduced by isolation of the medium carrying part of the plant, by the use of a temperature decoupler or of a measurement system with process diaphragm seal.

### Installation notes

Drive the system pressure free prior installation resp. deinstallation of the sensor.

The installation of the device into a closed off completely with process liquid filled connection can lead to destruction of the measuring membrane. The reduction of the volume of the liquid at screw-in leads to a very high pressure boosting, that can exceed the permitted maximum value by a multiple. Thus, before installation, the connection must be sufficiently emptied.

The screw-in of the thread process connection by using the terminal housing, the connection plug resp. the connection cable is not permitted.

The tightening of the thread process connection may only be done at the hexagon by a suitable spanner and with the maximum permitted torque strength.

The maximum permitted torque strength is 50 Nm.

The housing can be rotated every time, also at operation, mechanically by 330°.

The display can be rotated every time electrically by 180°.

### Air pressure compensation

Avoid the damaging or pollution of the pressure compensation system.

The hindrance of the pressure compensation can lead to faulty measuring results.

The filter element of the pressure compensation system is positioned at the side of the enclosure.

## Electrical connection

The electrical connection of the device must be carried out according to the respective country specific standards.

Incorrect installation or adjustment could cause applicationally conditioned risks.

## Potential equalization - earthing

The device must be grounded.

The earthing can be carried out by the metallic process connection.

The metallic parts of the device are electrically connected with the socket of the plug M12.

## Connection cable

Use only shielded signal and measurement wires and install these wires separated from power leading wires.

Connect the cable shield of a connected cable only at one side to earth, ideally at the installation place of the device.

## Supply voltage

The voltage applied to the terminal contacts may not exceed the maximum permitted supply voltage to avoid damage of the electronic.

The maximum permitted supply voltage range is:

All versions	11,2...35V <sub>DC</sub>
--------------	--------------------------

All connections are reverse polarity protected.

## Load resistor

### Signal 4...20 mA

A load resistor, e.g. the measuring shunt of an evaluation device, requires a minimum supply voltage. Dependent on the connected supply voltage, it results in a maximum value for this resistor, where a correct function is still possible.

This resistor can be calculated by the following term:

$$R_{Lmax} = (U_s - U_{Smin}) / 20mA$$

$R_{Lmax}$  = maximum load resistor

$U_s$  = connected supply voltage

$U_{Smin}$  = minimum supply voltage

### Load resistor characteristic

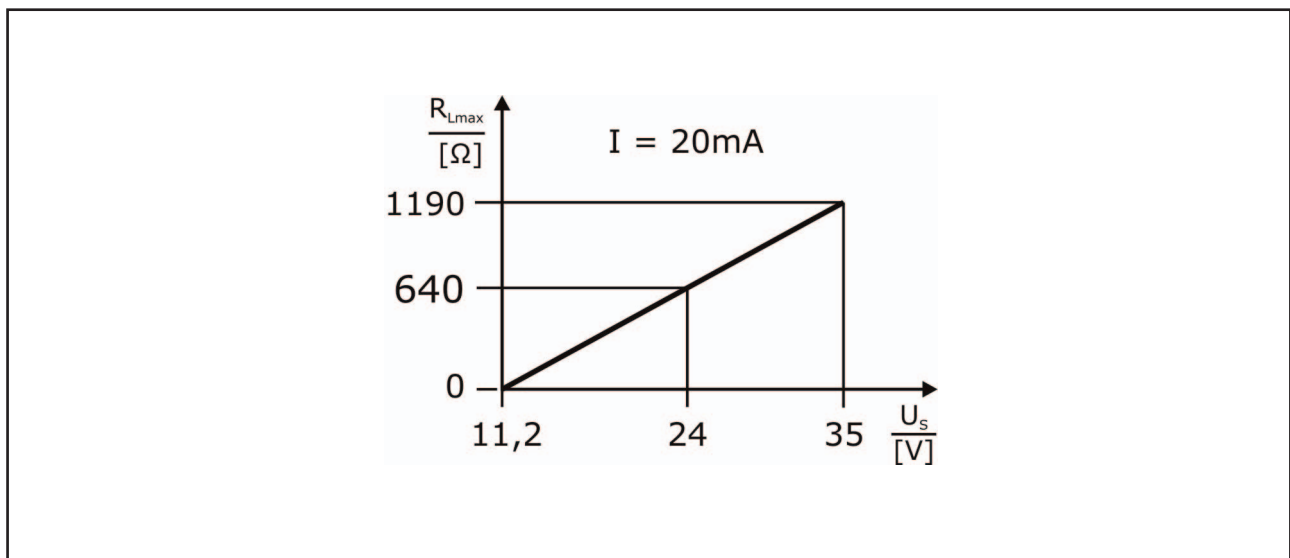

## Switch output

Inductive loads at the pnp switching outputs, e.g. relays or contactors may only be used with a free-wheeling diode or a RC protection circuit to avoid high voltage peaks.

The load at the PNP switching output will be connected to the terminal +terminal of the supply voltage by a semiconductor switch contactless and by this bounce-free.

At an activated switching state a positive signal near supply voltage is feed to the output.

At deactivated switching state and at failure of supply voltage the semiconductor switch is shut off.

The PNP switching output is current limited to 0,2...0,25 A and is overload and short circuit protected.

## Connection scheme

### Signal 2x PNP

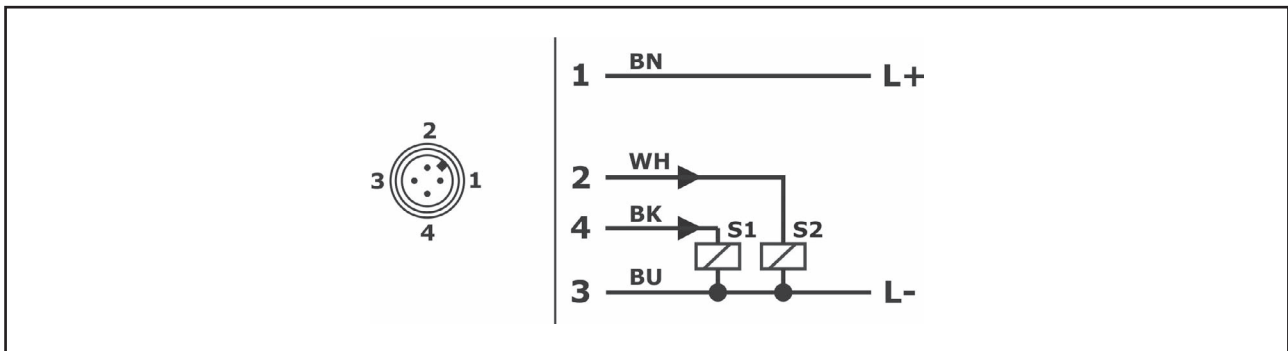

Conductor color standard connection cable M12:

BN = brown, WH = white, BU = blue, BK = black

The connection cable is not enclosed in the delivery contents.

### Signal 4...20 mA / 1x PNP

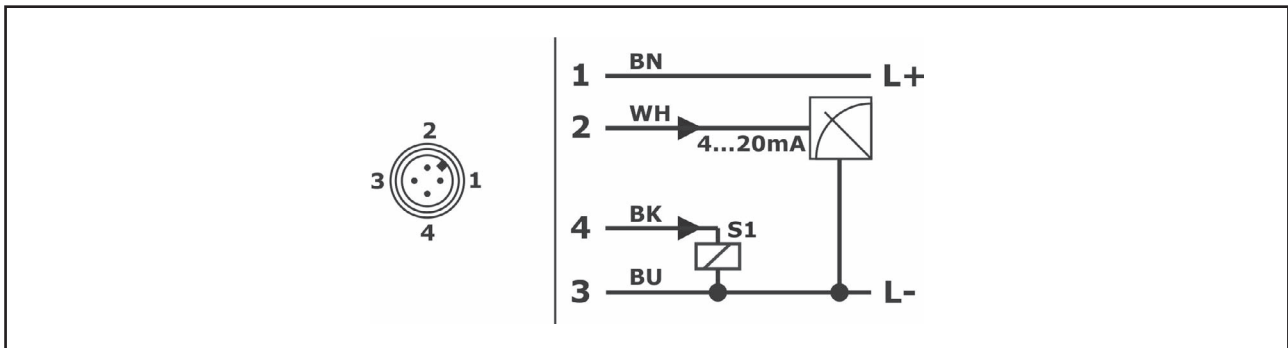

Conductor color standard connection cable M12:

BN = brown, WH = white, BU = blue, BK = black

The connection cable is not enclosed in the delivery contents.

### Signal 4...20 mA / 2x PNP

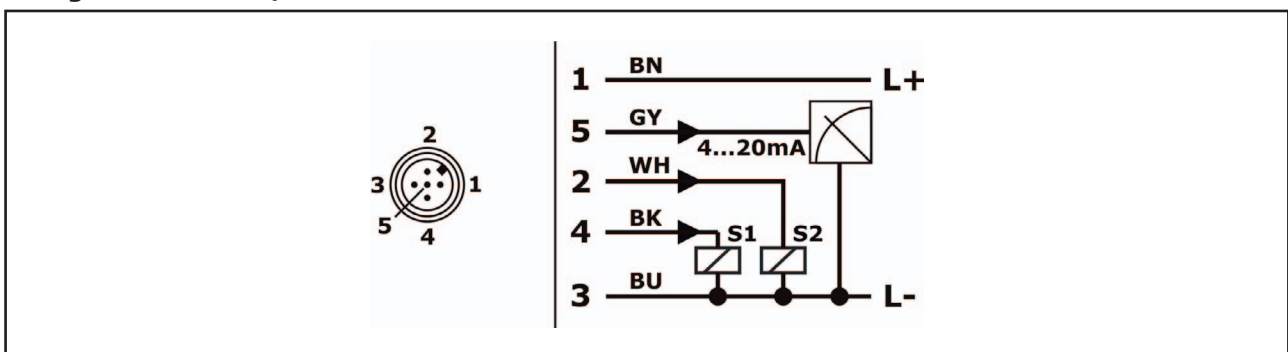

Conductor color standard connection cable M12:

BN = brown, WH = white, BU = blue, BK = black, GY = grey

The connection cable is not enclosed in the delivery contents.

**Signal 4...20 mA / 1x PNP / Desina**

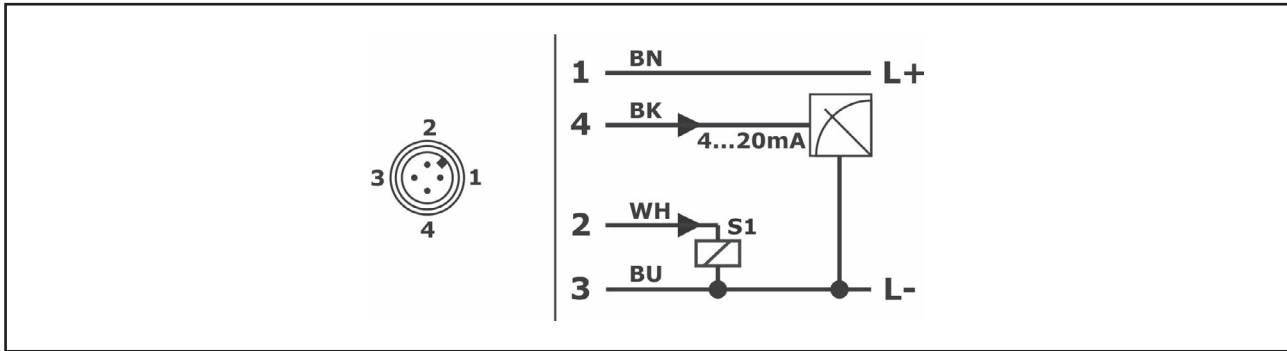

Conductor color standard connection cable M12:  
BN = brown, WH = white, BU = blue, BK = black  
The connection cable is not enclosed in the delivery contents.

# Operation

## Operation and display parts

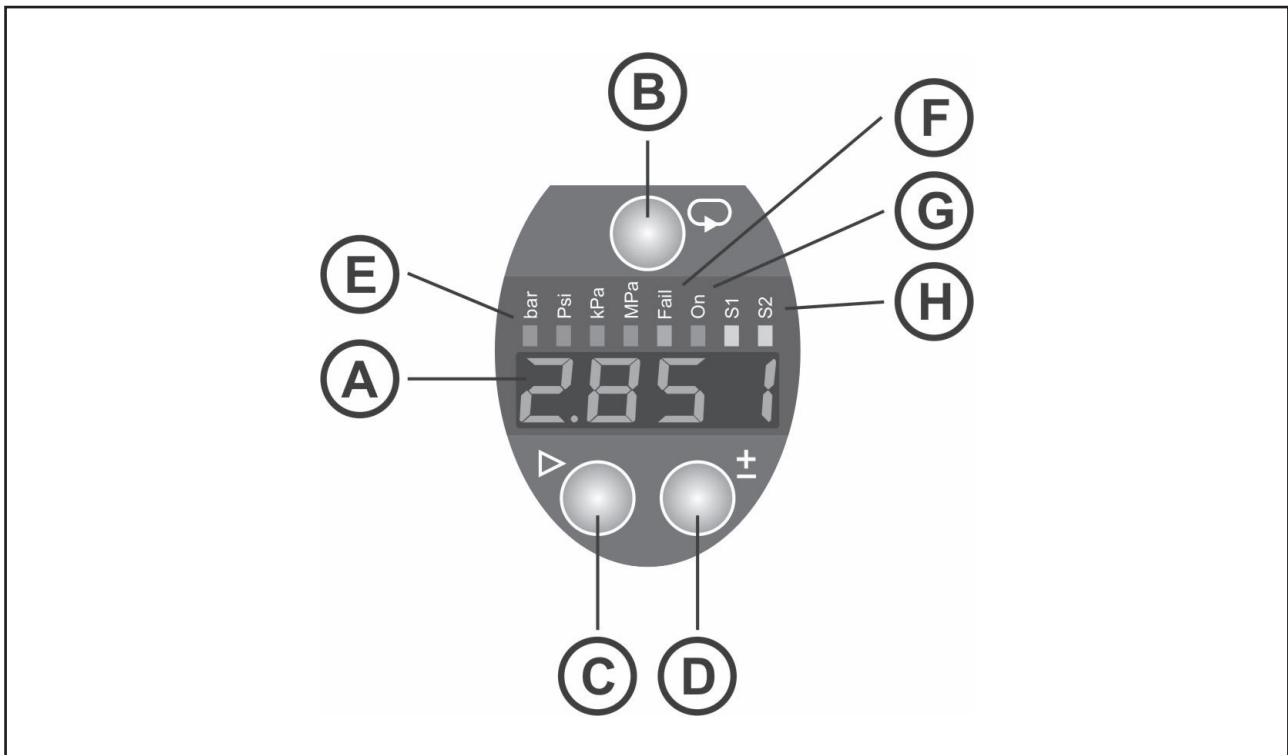

### A - LED display

- Display of measuring value and operation menu

### B - Key Set

- Access to operation menu
- In the selection menu entering the selected sub menu
- In the set menu applying the new value

### C - Key Change

- Change between sub menu
- Cancel value input without applying
- Changeover the counter advance sense of the key +/- from + resp. increasing to - resp. decreasing.

### D - Key +/-

- Value changing by + resp. increasing or - resp. decreasing. The counter advance sense is at first always + resp. increasing. Changing counter advance sense by the key Change.
- Change setting in a selection menu

### E - Unit LED

- Indication unit by green LED

### F - Error indication LED

- Indication abnormal behavior by red LED

### G - Operation LED

- Indication ready status by green LED

### H - Switch condition LED

- Indication of an active switch output by the respective yellow LED

---

## Function modes

### Run mode

The device records the applied physical measurand and proceeds the chosen functions according to the set parameter.

The active operation is confirmed by the green operation light-emitting diode.

The measuring value is displayed in the display window.

The chosen unit is marked through the come on of the respective green unit light-emitting diode.

The analogue output and the switching outputs are driven.

A turned on switch output is signaled by the come on of the respective yellow switch condition LED.

The exceedance of the frame specifications, abnormal behavior conditions and also device malfunctions are displayed static or flashing by the red error indication LED.

### Programming mode

Access to the function menus by the keys Set and Change (push 3 seconds).

- In the switch function menu – password 1903 – all the adjustable parameter and functions are chosen especially for the use of the device as switch.
- In the transmitter function menu – password 3009 – all the adjustable parameter and functions are chosen especially for the use of the device as transmitter by using the analogue output.
- In the switch point menu – password 1111 – only switch resp. switch back point of the PNP switch output resp. outputs are accessible for fast adjustment. The function of the switch outputs can be displayed.

The display settings, the service parameters system damping, error memory and minimum / maximum value memory and also the reset of all parameter to factory values can be equally accessed from the two menu structures switch function menu and transmitter function menu.

## Switch output S1 / S2

### Switch Point / Reset Switch Point

The input values refers to the current measuring value or acc. to display scaling.

The reset switch point must be lower or equal to the switch point.

For both switch functions, there is no default minimum difference (hysteresis) between switch resp. switch back point resp. between upper and lower switch point.

If the switch back point is set higher or equal to the switch point resp. the lower switch point is set higher or equal to the upper switch point the switch back point is set automatically to the switch point resp. the lower switch point is set automatically to the upper switch point.

The red error indication LED is flashing.

In the error memory service (SEr) / error memory (ErrM) there will be the indication of the concerning switching output (S1oG or S2oG).

### Switch Delay Time / Reset Switch Delay Time

The activation resp. deactivation of the switch output can be biased with a delay time (resolution 0,1s), to realize simple sequence control system.

## Operating Mode

The operating mode defines the function direction of the switch output.

Normal Open / NO

- At the output there is no signal, if the switch condition is not fulfilled.
- At the output there is a signal, if the switch condition is fulfilled.

Normal Close / NC

- At the output there is a signal, if the switch condition is not fulfilled.
- At the output there is no signal, if the switch condition is fulfilled.

## Hysteresis function

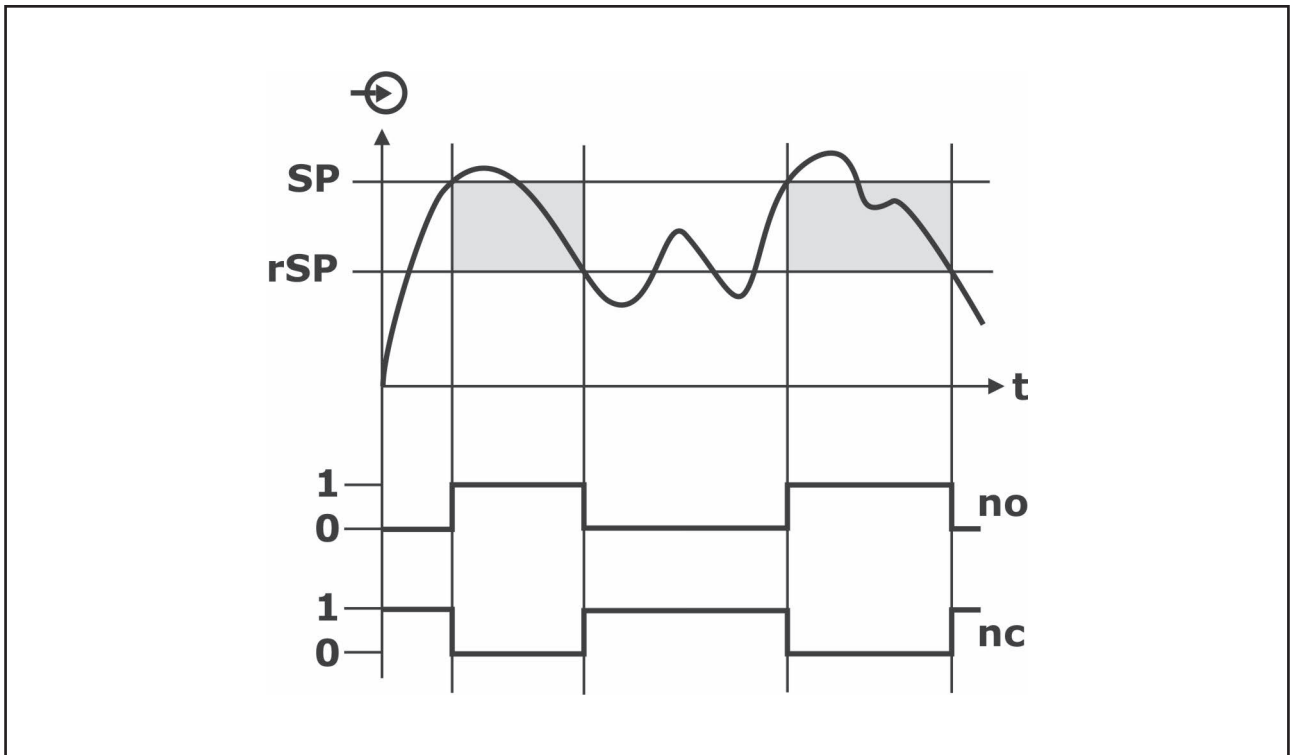

The hysteresis function realizes a stable switch state, independent from system conditioned signal fluctuations around the adjusted set point.

It can be used for realizing a signal controlled two-position control.

The switch range is determined by input the switch point and switch back point.

The switch output is activated, if the current measuring value exceeds the switch point and if the set switch point delay time has been expired.

The switch output is deactivated, if the current measuring value exceeds the reset switch point and if the set reset switch point delay time has been expired.

The actual applied measuring signal can be applied or an arbitrary value can be set as switch resp. switch back point.

## Window function

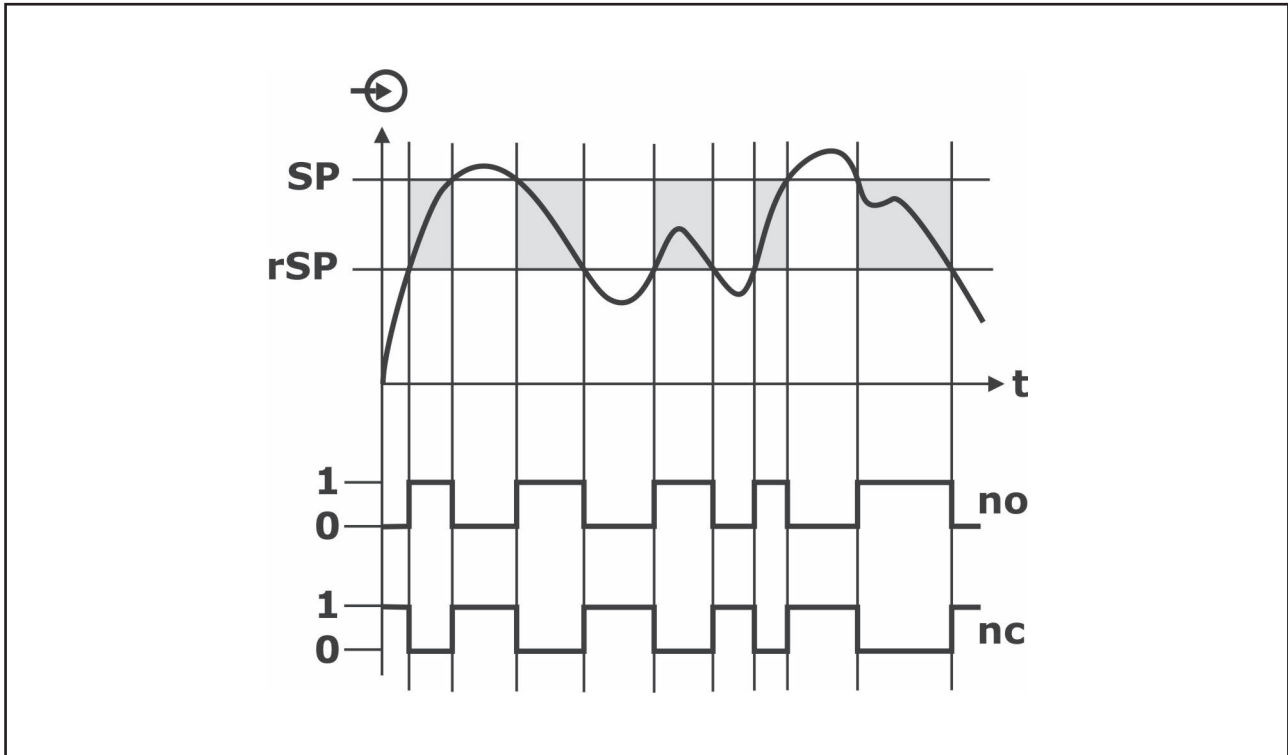

The window function realizes a signal range – acceptance region –, where the switch output is set to a definitive switch state.

The switch range is determined by input the switch point and switch back point.

The switch output is activated, if the current measuring value is inside the area that is defined by the switch point and the reset switch point and if the set switch point delay time has been expired.

The switch output is deactivated, if the current measuring value is outside the area that is defined by the switch point and the reset switch point and if the set reset switch point delay time has been expired.

The actual applied measuring signal can be applied or an arbitrary value can be set as switch resp. switch back point.

## Error Indication Function

The switch output S1 can be alternatively used for error indication function. Doing this a switch action happens, if the output signal becomes higher than 20mA resp. lower than 4mA.

## Signal output

The nominal values of the analogue signal (4/20 mA) refers to the set signal zero and signal end value.

### Error Signal

Defines, the analogue output signal regarding operating range and if errors are registered.

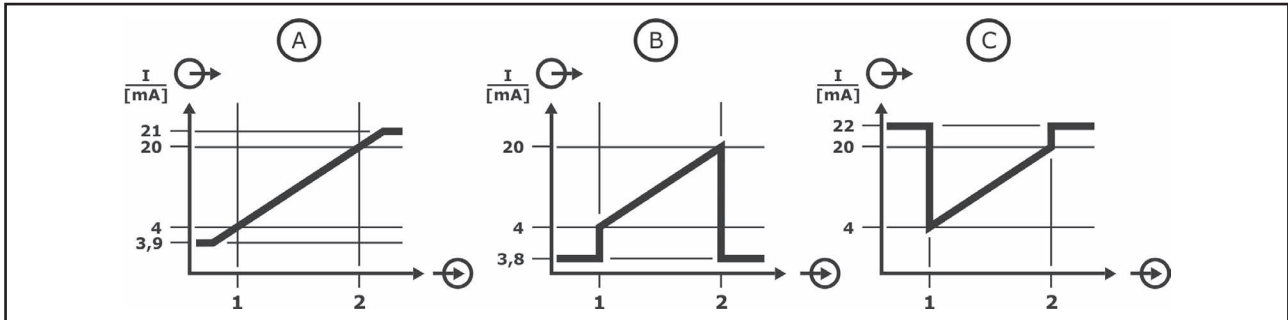

A - Off >> 3.9-21mA

B - 3.8mA

C - 22mA

### Invert Signal

Inverts the analogue output signal.

- 4-20 mA >> 20-4 mA

# Menu structure

## Menu structure switching function - password 1903

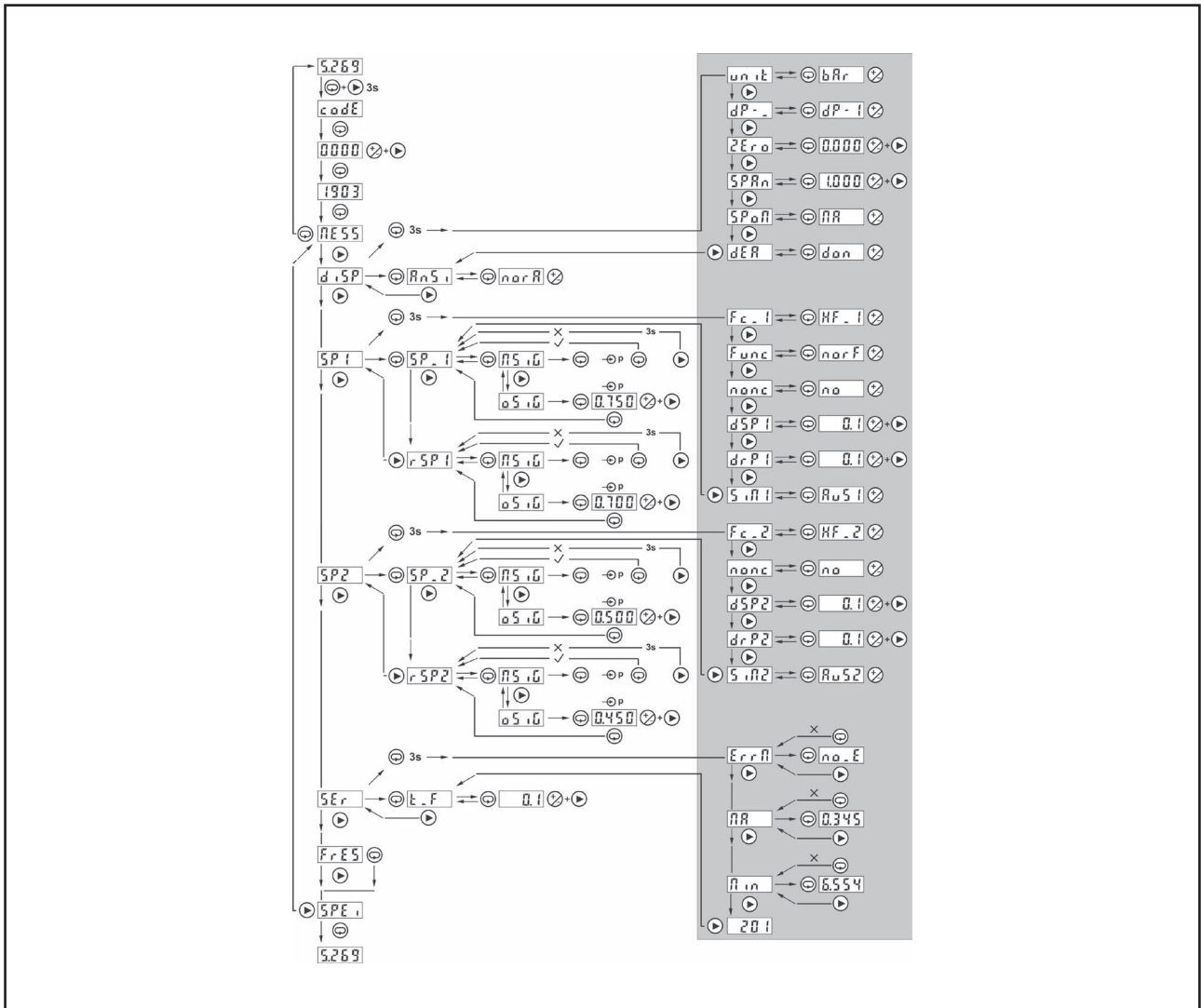

# Menu structure transmitter function - password 3009

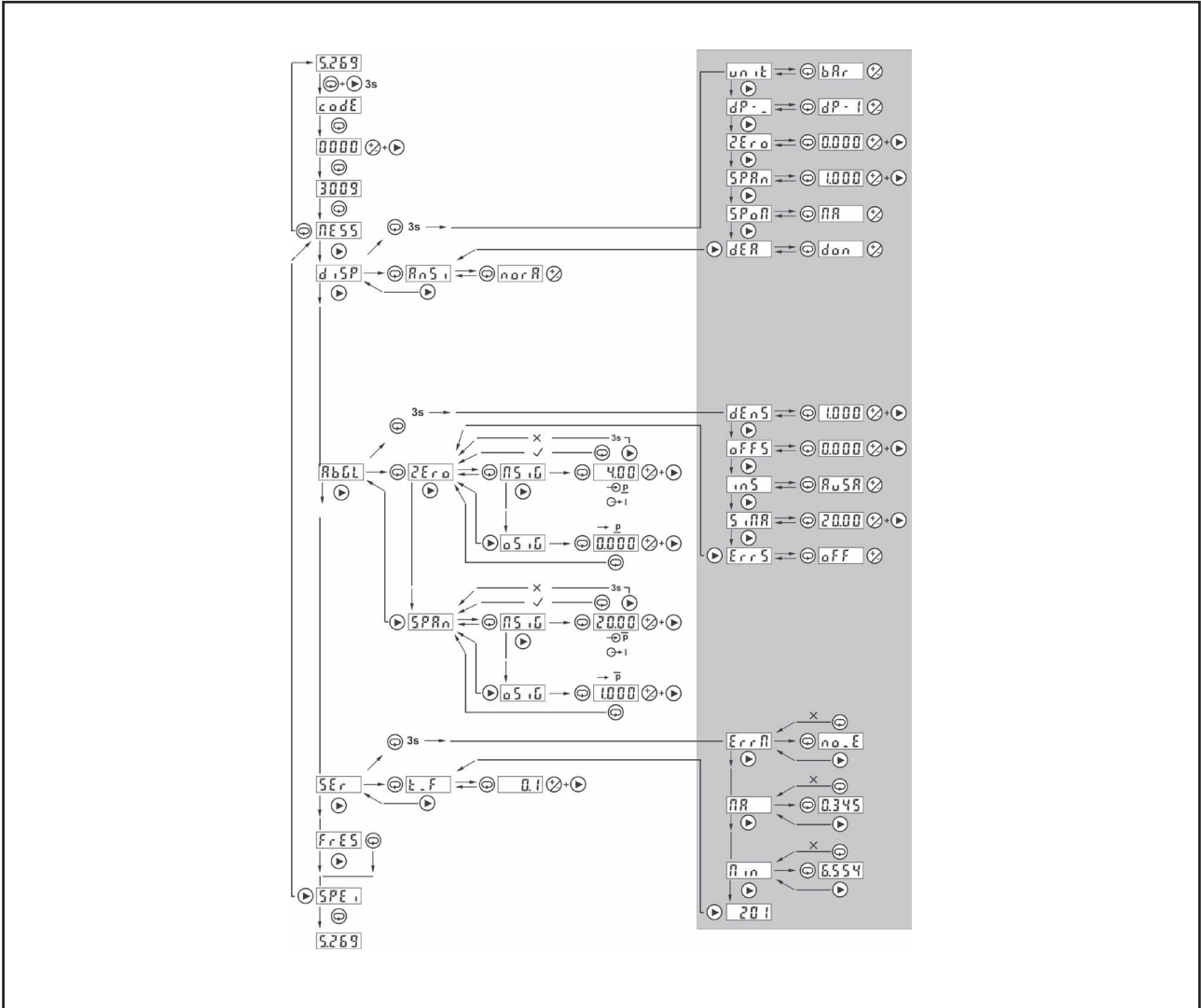

## Menu structure switching point - password 1111

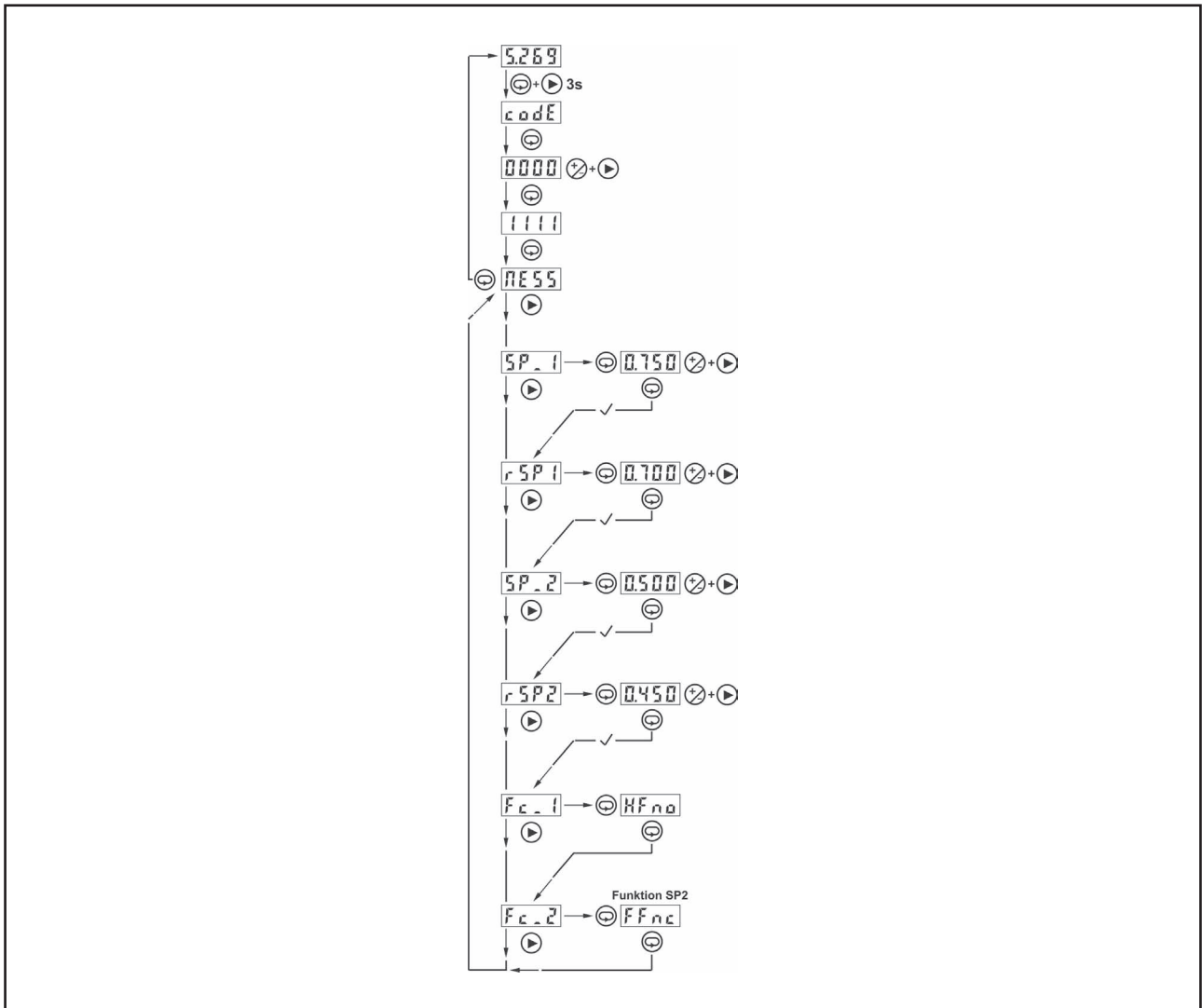

## Parameter overview

Menu group	Function	Input	Description
code		1903	Password input for the access to the transmitter function menu
		3009	Password input for the access to the switching function menu
		1111	Password input for the access to the switching point menu

Menu group	Function	Input	Description
dISP			DISPLAY – includes all parameters concerning the display
	RnSi	norR	View normal
		GE dR	View rotated by 180°
	Unit	bRR	Unit bar
		KPR	Unit kPa perhaps not possible when pressure range is too high
		PSI	Unit psi perhaps not possible when pressure range is too high
		MPR	Unit MPa perhaps not possible when pressure range is too low
			If the gradient of the characteristic >> pressure – display << is changed in the menu group Adjustment, the indication of the unit is deactivated because this value is wrong now. An offset correction, that means an even shift of the lower and the upper pressure reference value does not change the gradient of the characteristic. When changing this settings the switch resp. switch back point are adjusted corresponding to the changed characteristic >> pressure – display <<.
	dP -	dP - 0	No decimal point, the measuring value is displayed without decimal place
		dP - 1	One decimal point, the measuring value is displayed with one decimal place
		dP - 2	Two decimal point, the measuring value is displayed with two decimal place
		dP - 3	Three decimal point, the measuring value is displayed with three decimal place
			If an increase of the display resolution is not possible, there will be a scaling correct to the unit. At a conversion e.g. at unit kPa with one decimal point to three decimal points, there will be proceeded automatically a conversion of the unit to bar. Otherwise there is only a shift of the decimal point. When changing this settings the switch resp. switch back point are adjusted corresponding to the changed characteristic >> pressure – display <<.
	ZEro		Freely adjustable lower display value. This value equals the adjusted lower pressure reference value. When changing this value the switch resp. switch back point are adjusted corresponding to the changed characteristic >> pressure – display <<.
	SPRn		Freely adjustable upper display value. This value equals the adjusted upper pressure reference value. When changing this value the switch resp. switch back point are adjusted corresponding to the changed characteristic >> pressure – display <<.
	SPoR	RR	Display measuring value - the actual measuring value is shown in the display
		SPR	Display switching value - the upper limit value of the switch point 1 is shown in the display
	dER	don	Display indication on – measurement value and status LED are indicated
		doff	Display indication off – measurement value and unit LED are deactivated in the run mode. The operation, error and switching condition indicator LED are still in process. When accessing the password input by simultaneous pushing the two operation keys +/- and > for three seconds, the complete display is switched on again.

Menu group	Function	Input	Description
SP1			Switching output 1 – includes all parameters concerning the switching output 1
	SP_1	HS_1	Adjustment with applied signal – The actual applied pressure value is captured as switch point resp. upper switch point
		oS_1	Adjustment without applied signal – The actual switch point / upper switch point is shown in the display and can now be adjusted by the operation keys +/- and >.
	rSP1	HS_1	Adjustment with applied signal – The actual applied pressure value is captured as switch back point resp. lower switch point
		oS_1	Adjustment without applied signal – The actual switch back point / lower switch point is shown in the display and can now be adjusted by the operation keys +/- and >.
	Fc_1	HF_1	The switching output 1 operates in hysteresis function with switch point and switch back point
		FF_1	The switching output 1 operates in window function with lower and upper switch point
	Func	norF	Normal function – The switching output 1 operates in hysteresis or in window function
		ErrF	Error indication function – The switching output 1 operates in error indication function for the analogue current output. At underrun of 4 mA resp. at exceedance of 20 mA, the switching output 1 is activated depending on the settings as closed-circuit or as open-circuit.
	nonc	no	The switching output 1 operates in open-circuit principle resp. – no normally open
		nc	The switching output 1 operates in closed-circuit principle resp. – nc normally closed
	dSP1		Switch delay time for switch point / upper switch point of switching output 1. The switching output 1 is only activated, if after the entrance of the switch condition and after the set switch delay time the pressure signal already fulfills the switch conditions. By this e.g. short pressure bursts can be eliminated. The adjustment range is 0...99 seconds, in steps of 0,1 seconds
	drP1		Switch delay time for switch back point / lower switch point of switching output 1. The switching output 1 is only activated, if after the entrance of the switch back condition and after the set switch delay time the pressure signal already fulfills the switch back conditions. By this e.g. short pressure bursts can be eliminated. The adjustment range is 0...99 seconds, in steps of 0,1 seconds
	S_n1	RuS1	Simulation – the switching output 1 is deactivated
E_n1		Simulation – the switching output 1 is activated	

Menu group	Function	Input	Description
SP2			Switching output 2 – includes all parameters concerning the switching output 2
	SP_2	HS_2	Adjustment with applied signal – The actual applied pressure value is captured as switch point resp. upper switch point
		oS_2	Adjustment without applied signal – The actual switch point / upper switch point is shown in the display and can now be adjusted by the operation keys +/- and >.
	rSP2	HS_2	Adjustment with applied signal – The actual applied pressure value is captured as switch back point resp. lower switch point
		oS_2	Adjustment without applied signal – The actual switch back point / lower switch point is shown in the display and can now be adjusted by the operation keys +/- and >.
	Fc_2	HF_2	The switching output 2 operates in hysteresis function with switch point and switch back point
		FF_2	The switching output 2 operates in window function with lower and upper switch point
	nonc	no	The switching output 2 operates in open-circuit principle resp. – no normally open
		nc	The switching output 2 operates in closed-circuit principle resp. – nc normally closed
	dSP2		Switch delay time for switch point / upper switch point of switching output 2. The switching output 2 is only activated, if after the entrance of the switch condition and after the set switch delay time the pressure signal already fulfills the switch conditions. By this e.g. short pressure bursts can be eliminated. The adjustment range is 0...99 seconds, in steps of 0,1 seconds
	drP2		Switch delay time for switch back point / lower switch point of switching output 2. The switching output 2 is only activated, if after the entrance of the switch back condition and after the set switch delay time the pressure signal already fulfills the switch back conditions. By this e.g. short pressure bursts can be eliminated. The adjustment range is 0...99 seconds, in steps of 0,1 seconds
	S_n2	RuS2	Simulation – the switching output 2 is deactivated
		E_n2	Simulation – the switching output 2 is activated

Menu group	Function	Input	Description	
RbGL			Adjustment – includes all parameters concerning the pressure adjustment	
	ZEro	RS LG	Adjustment lower pressure reference value with applied signal - The actual applied pressure value is captured as lower pressure reference value. - The output current signal of 4mA, that can adjusted by the control keys +/- and > arbitrarily is assigned to this pressure reference value. Adjustment range 3,9mA to 21mA. - The ZEro value of the display refers to this pressure reference value. - If the adjusted measuring range is lower than 25% of the nominal measuring range, the change will be refused and the display shows EEEE.	
		o5 LG	Adjustment lower pressure reference value without applied signal - The freely adjustable pressure value, in the set unit - Unit-, is captured as lower pressure reference value. - The ZEro value of the display refers to this pressure reference value. - The lower output current end value, 4mA, refers to this pressure reference value. - The measuring span cannot be adjusted lower than 25% of the nominal measuring range.	
			If the end value will not be changed by the same amount as the zero value, the gradient of the characteristic >> pressure – display << is changed and by this the indication of the unit is deactivated because it is no more longer correct.	
	SPAn	RS LG	Adjustment upper pressure reference value with applied signal - The actual applied pressure value is captured as upper pressure reference value. - The output current signal of 20mA, that can adjusted by the control keys +/- and > arbitrarily is assigned to this pressure reference value. Adjustment range 3,9mA to 21mA. - The SPAn value of The display refers to this pressure reference value. - If the adjusted measuring range is lower than 25% of the nominal measuring range, the change will be refused and the display shows EEEE.	
			o5 LG	Adjustment upper pressure reference value without applied signal - The freely adjustable pressure value, in the set unit - Unit-, is captured as upper pressure reference value. - The SPAn value of The display refers to this pressure reference value. - The upper output current end value, 20mA, refers to this pressure reference value. - The measuring span cannot be adjusted lower than 25% of the nominal measuring range.
				If the zero value will not be changed by the same amount as the end value, the gradient of the characteristic >> pressure – display << is changed and by this the indication of the unit is deactivated because it is no more longer correct.
				Freely adjustable density correction factor in the range of 0.500 to 2.000. This factor is applied on the measured pressure concerning to the adjusted pressure range. If a density correction factor divergent to 1 is set, the indication of the unit is deactivated, because the gradient of the characteristic >> pressure – display << has changed and the unit is no more longer correct.
		oFF5	The measured pressure in the set unit will be shift by the set value accordingly to the sign by maximum ± 5% of the nominal measuring range. Upper and lower pressure reference value will be shift by the same value. To get e.g. a display (desired value) of 0.000 resp. an output signal of 4mA at a shown installation dependent pressure of 0.004, the difference between desired pressure value und shown pressure value (0.000 – 0.004) must be input. Thus the value -0.004 must be input.	
	in5	RUSR	The output current signal corresponds to the assignment of the adjustment >> 4...20mA	
		E inR	The output current signal behaves inverted to the assignment of the adjustment >> 20...4mA	
	S inR		The analogue current output signal can be arbitrarily simulated in the whole utilizable range from 3,8 mA to 22mA by using the operation keys +/- and >.	
	Err5	oFF	The current output signal operates linear in the range from 3,9 mA to 21,0 mA. A signal output besides this limits is not possible, the end values are kept at exceedance. An error signal current output at underrun resp. exceedance does not occur.	
		F538	The current output signal operates linear in the range from 4,0 mA to 20,0 mA. At underrun of 4mA resp. at exceedance of 20mA a constant signal of 3,8 mA is generated.	
		F522	The current output signal operates linear in the range from 4,0 mA to 20,0 mA. At underrun of 4mA resp. at exceedance of 20mA a constant signal of 22 mA is generated.	

Menu group	Function	Input	Description	
SEr			Service – includes all parameters concerning service purposes	
	t_F		Input of the system damping for extraction of short pressure bursts resp. also for reassuring of cyclic fluctuating pressure signals. The adjustment range is 0...40 seconds, in steps of 0,1 seconds	
	Errn	noE		No error recorded in the error memory.
		dun		Permanent underrun of the maximum permitted system pressure.
		dob		Permanent transgression of the maximum permitted system pressure.
		FLRS		An error in the internal nonvolatile data memory (flash) has been detected.
		dunb		The lower measuring range limit value (display zero) has been underrun.
		duEb		The upper measuring range limit value (display span) has been exceeded.
		Runb		The lower limit value of the analogue output, 3,9 mA, has been underrun.
		RuEb		The upper limit value of the analogue output, 21 mA, has been exceeded.
		S1ob		The switch back point rSP1 of the switching output 1 has been adjusted higher or equal to the switch point SP_1.
		S2ob		The switch back point rSP2 of the switching output 2 has been adjusted higher or equal to the switch point SP_2.
		S1oP		The switching output 1 is not activated, although it should be.
		S2oP		The switching output 2 is not activated, although it should be.
rRn		An error in the internal working memory (RAM) has been detected.		
NR		Maximum value memory – display of the highest measured pressure value.		
Rin		Minimum value memory – display of the lowest measured pressure value.		
Z01		Version number of the installed firmware		
FRES			Factory Reset – reset of all parameters to factory values	
SPEi			Storage – loss protected storage of all parameters	

Menu group	Function	Input	Description
<b>Switching point menu</b>			
SP_1			The current switch point / upper switch point of switching output 1 is shown in the display and can be adjusted by the control keys +/- and >.
rSP1			The current switch back point / lower switch point of switching output 1 is shown in the display and can be adjusted by the control keys +/- and >.
SP_2			The current switch point / upper switch point of switching output 2 is shown in the display and can be adjusted by the control keys +/- and >.
rSP2			The current switch back point / lower switch point of switching output 2 is shown in the display and can be adjusted by the control keys +/- and >.
Fc_1			The set switching function of the switching output 1 is displayed. This setting can not be changed here.
	HFno		The switching output 1 operates in hysteresis function with working principle normal open
	HFnc		The switching output 1 operates in hysteresis function with working principle normal closed
	FFno		The switching output 1 operates in window function with working principle normal open
	FFnc		The switching output 1 operates in window function with working principle normal closed
Fc_2			The set switching function of the switching output 2 is displayed. This setting can not be changed here.
	HFno		The switching output 2 operates in hysteresis function with working principle normal open
	HFnc		The switching output 2 operates in hysteresis function with working principle normal closed
	FFno		The switching output 2 operates in window function with working principle normal open
	FFnc		The switching output 2 operates in window function with working principle normal closed

## Error indication at operation

The red error indication light-emitting diode indicates the exceedance of operation limit values, faulty inputs or also device errors.

The information, what reason has led to an error indication can be found in each of the two function menus in the area extended functions of the menu point service.

Only the last detected error is displayed.

The error information in the service menu is not stored in the case of a voltage fail.

At every restart of the device the system is completely tested concerning the parameters and settings.

light-emitting diode	error indication in service menu	description / remedy
red yellow – flashing	no	Short circuit at the switching output, whose yellow switching condition LED is flashing. Check the load at the respective switching output.
red	<b>d u n</b>	Permanent underrun of the minimum permitted system pressure. Check the system pressure in your plant. If the system pressure is within the permitted range, there can be an irreversible device defect.
red	<b>d o b</b>	Permanent exceedance of the maximum permitted system pressure. Check the system pressure in your plant. If the system pressure is within the permitted range, there can be an irreversible device defect.
red	<b>F L R S</b>	An error in the internal nonvolatile data memory (flash) has been detected. If the error cannot be removed after repeated restart of the device by short voltage interrupts, there can be an irreversible device defect.
red – flashing	<b>d u n t</b>	The lower measuring range limit value (value in Disp-2Ero) has been underrun. Check the system pressure of your plant. This pressure may be lower than the measuring range zero value.
red – flashing	<b>d u E b</b>	The upper measuring range limit value (value in Disp-SPAn) has been exceeded. Check the system pressure of your plant. This pressure may be higher than the measuring range end value.
red – flashing	<b>R u n t</b>	The lower limit value of the analogue signal current output, 3,9mA, has been underrun. Check the adjustment of the analogue output. The system pressure is lower than the pressure concerning to the analogue output at 3,9mA.
red – flashing	<b>R u E b</b>	The upper limit value of the analogue signal current output, 21mA, has been exceeded. Check the adjustment of the analogue output. The system pressure is higher than the pressure concerning to the analogue output at 21mA.
red – flashing	<b>S 1 o t</b>	The switch back point rSP1 of the switching output 1 has been adjusted higher or equal to the switch point SP_1. Check the adjustment of the switching output 1
red – flashing	<b>S 2 o t</b>	The switch back point rSP2 of the switching output 2 has been adjusted higher or equal to the switch point SP_2. Check the adjustment of the switching output 2
red – flashing	<b>S 1 o P</b>	An error has been detected at switching output 1. Detach the output load of the switching output 1. If the error cannot be removed after repeated restart of the device by short voltage interrupts, there can be an irreversible device defect.
red – flashing	<b>S 2 o P</b>	An error has been detected at switching output 2. Detach the output load of the switching output 2. If the error cannot be removed after repeated restart of the device by short voltage interrupts, there can be an irreversible device defect.
red – flashing	<b>r R n</b>	An error in the internal working memory (RAM) has been detected. If the error cannot be removed after repeated restart of the device by short voltage interrupts, there can be an irreversible device defect.
<b>EEEE</b>	Display while operation	Wrong password entered – Acknowledgment by control key „Enter“ Measuring range adjusted to ± 25% of the nominal range – Readjustment necessary Maximum display value of 9999 has been exceeded – Readjustment necessary
<b>- EEE</b>	Display while operation	Minimum display value of -999 has been underrun – Readjustment necessary
<b>0.004</b>	Display while operation	At an offset adjustment the unit LED goes out Always zero and end value must be changed by the same amount. If e.g. only the zero value is changed, the characteristic pressure – display is no more longer correct

---

## Maintenance

The device is free of maintenance.

Special substances can lead to solid coatings on the membrane.

Seized depositions can lead to faulty measurement results.

In the case of coat forming liquids the membrane must be regularly cleaned e.g. with clear water.

Don't use sharp tools or aggressive chemicals for cleaning.

---

## Repair

A repair may only be carried out by the manufacturer.

If the device must be sent back for repair, the following informations must be enclosed:

- An exact description of the application.
- The chemical and physical characteristics of the product.
- A short description of the occurred error.

Before returning the device for repair, the following measures must be proceeded:

- All adhesive product residues must be removed. This is especially important, if the product is unhealthily, e.g. caustic, toxic, carcinogenic, radioactive etc.
- A returning must be refrained, if it is not possible by 100% to remove the unhealthily product completely, because e.g. it is penetrate into cracks or is diffused through plastic.

# Technical Data

## Auxiliary power supply

Supply voltage $U_S$	11,2..35 $V_{DC}$ , reverse polarity protected
Residual ripple $U_{PP}$	$\leq 2 V_{PP} / U_{Smin} \leq U_S \leq U_{Smax}$
Supply current $I_{In}$	$\leq 50$ mA Analogue output max. 22,5 mA Switch output with no load

## Output Switch output

Function	PNP switching to +L
Output voltage $U_{Out}$	$U_{Out} \geq U_S - 2$ V
Output current $I_l$	0... $\leq 250$ mA, current limited, short circuit protected
Step response time $T_{90}$	$\leq 3$ ms ( $t_d = 0$ s)
Rise time $T_{90}$	$< 30$ $\mu$ s ( $R_l < 3$ k $\Omega$ / $I_{Out} > 4,5$ mA)
Start-up time $t_{on}$	$\leq 1$ s
Switch cycles	$\geq 100.000.000$

## Output Signal 4...20mA

Operating range $I_{Out}$	3,9 mA ... 21 mA, min. 3,8mA, max. 22 mA
Permitted load $R_l$	$\leq (U_S - 11,2$ V) / 20mA + 280 $\Omega$
Step response time $T_{90}$	$\leq 3$ ms ( $t_d = 0$ s)
Start-up time $t_{on}$	$\leq 1$ s

## Measuring accuracy

Reference conditions	EN/IEC 60770-1 resp. EN/IEC 61003-1
	T = 25 °C, relative humidity 45...75 %, environmental air pressure 860..1060 kPa
Calibration position	Vertical, process connection bottom side
Warm-up time	$\leq 240$ s

Characteristic deviation <sup>3) 5) 6) 12)</sup>	$\leq \pm 0,5\%$ FS <sup>2)</sup>
Nonlinearity <sup>6) 12)</sup>	$\leq \pm 0,3\%$ FS <sup>2)</sup>
Hysteresis <sup>6) 12)</sup>	$\leq \pm 0,1\%$ FS <sup>2)</sup>
Influence of supply voltage	$\leq \pm 0,02\%$ FS <sup>2)</sup> / 10V
Long term drift <sup>6) 12)</sup>	$\leq \pm 0,2\%$ FS <sup>2)</sup> / year - not cumulative
Temperature deviation <sup>6) 12)</sup>	$T_k$ <sup>4)</sup> Zero / $\leq \pm 0,2\%$ FS <sup>2)</sup> / 10 K (0...80°C) $\leq \pm 0,3\%$ FS <sup>2)</sup> / 10 K (-20...0°C / +80...+150°C)
	Measuring range 0...0,1 bar / 0...0,25 bar $\leq \pm 0,4\%$ FS <sup>2)</sup> / 10 K (0...+80°C) $\leq \pm 0,6\%$ FS <sup>2)</sup> / 10 K (-20...0°C / +80...+150°C)
	$T_k$ <sup>4)</sup> Span $\leq \pm 0,2\%$ FS <sup>2)</sup> / 10 K (0...80°C) $\leq \pm 0,3\%$ FS <sup>2)</sup> / 10 K (-20...0°C / +80...+150°C)

## Mounting position

Maximum deviation <sup>10)</sup>	≤ 10 mbar
----------------------------------	-----------

<sup>2)</sup> Referring to nominal measuring span resp. full scale (FS)

<sup>3)</sup> Nonlinearity + Hysteresis + Reproducibility

<sup>4)</sup>  $T_k$  = Temperature coefficient

<sup>5)</sup> Limit value adjustment acc. to EN/IEC 60770-1

<sup>6)</sup> Specification for TD <sup>7)</sup> = 1 (adjusted measuring range = nominal measuring range).

Specification for TD <sup>7)</sup> ≥ 1 (adjusted measuring range ≤ nominal measuring range) = specification at nominal measuring range x TD <sup>7)</sup>

<sup>7)</sup> Turn-Down TD = nominal measuring range (FS <sup>2)</sup>) / adjusted measuring range)

<sup>10)</sup> Device rotated by 180°, process connection upside

<sup>12)</sup> Higher values for special measuring range

## Process conditions

The permitted process temperature range results from the combination of standard range, expansion and limitation, whereby the range is defined by the narrowest limitation.

Process temperature	-20°C...+150°C <i>Limitation</i> Gasket - EPDM -40°C...+140°C
---------------------	---

Process pressure	Pressure range	Over/Burst pressure	Vacuum
[R] Gauge pressure	-1...0 bar [R]	5 bar / 6 bar	0 bar [A]
[A] Absolute pressure	-1...+1 bar [R]	10 bar / 12 bar	0 bar [A]
	0...0,1 bar [R/A]	1 bar / 2 bar	0 bar [A]
	0...0,25 bar [R/A]	2 bar / 2,4 bar	0 bar [A]
	0...0,4 bar [R/A]	2 bar / 2,4 bar	0 bar [A]
	0...0,6 bar [R/A]	4 bar / 4,8 bar	0 bar [A]
	0...1 bar [R/A]	5 bar / 6 bar	0 bar [A]
	0...2,5 bar [R/A]	10 bar / 12 bar	0 bar [A]
	0...4 bar [R/A]	17 bar / 20,5 bar	0 bar [A]
	0...6 bar [R/A]	35 bar / 42 bar	0 bar [A]
	0...10 bar [R/A]	35 bar / 42 bar	0 bar [A]
	0...16 bar [R/A]	80 bar / 96 bar	0 bar [A]
	0...25 bar [R/A]	80 bar / 96 bar	0 bar [A]

## Environmental conditions

Environmental temperature	-40°C...+85°C
Protection	IP68 [≤ 1 mWs-1h] (EN/IEC 60529)
Climatic classification	4K4H [-20...+55°C / 4...100%] (EN/IEC 60721-3-4)
Shock classification	50 g [11ms] (EN/IEC 60068-2-27)
Vibration classification	20 g [10 - 2000 Hz] (EN/IEC 60068-2-6)
EM compatibility	Operation device class B / Industrial range (EN/IEC 61326)
Weight	0,35 kg

## Materials - process wetted

Membrane	Steel 1.4435 (316L)
Process connection	Steel 1.4435 (316L)
Gaskets	FPM – fluorelastomere (Viton®) EPDM – ethylene-propylene-dienmonomere

---

## Materials - not process wetted

Terminal enclosure	CrNi-steel
Control panel surface	PC / PES
Electrical connection part	Device plug PUR
Pressure compensation element	Enclosure PBT Membrane PES
Gaskets	FPM – fluorelastomere (Viton®)
Pressure transmitting liquid	Synthetic oil, FDA-listed for food industry

## Dimension drawings

### Terminal enclosure

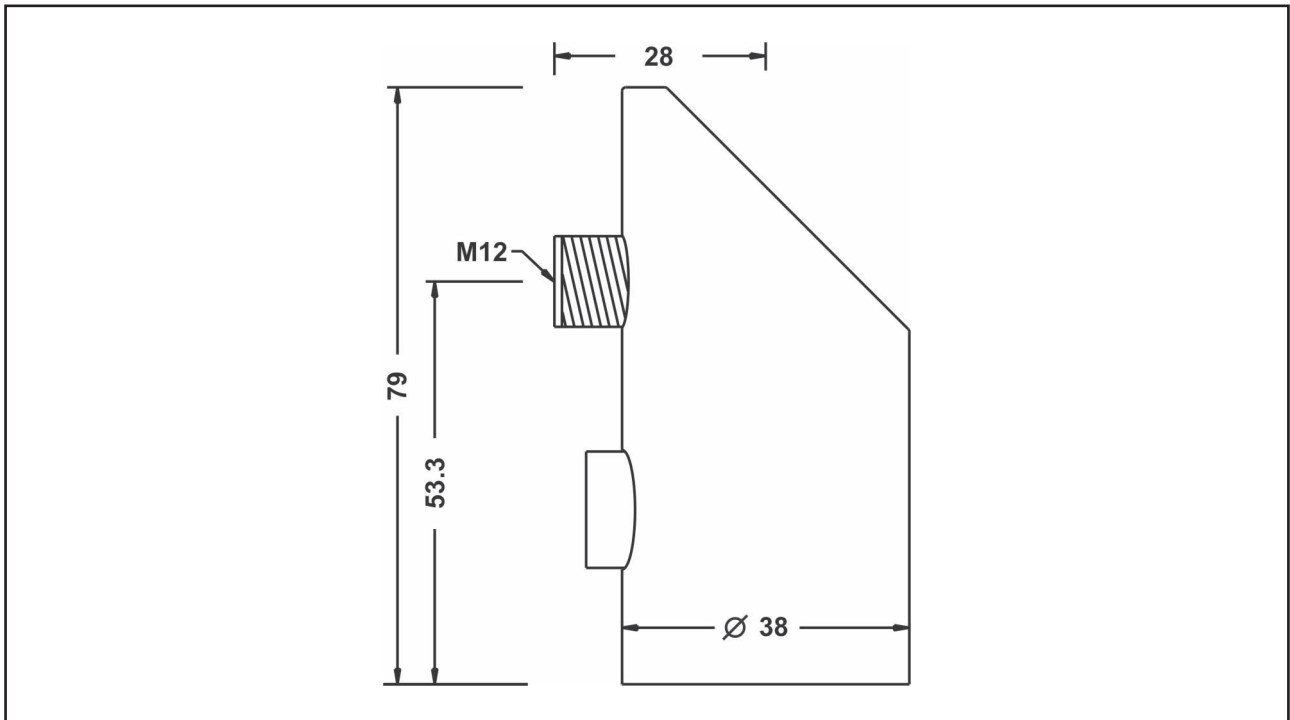

# Process connection

Type 5 - G 1" ISO 228-1 - flush-mounted

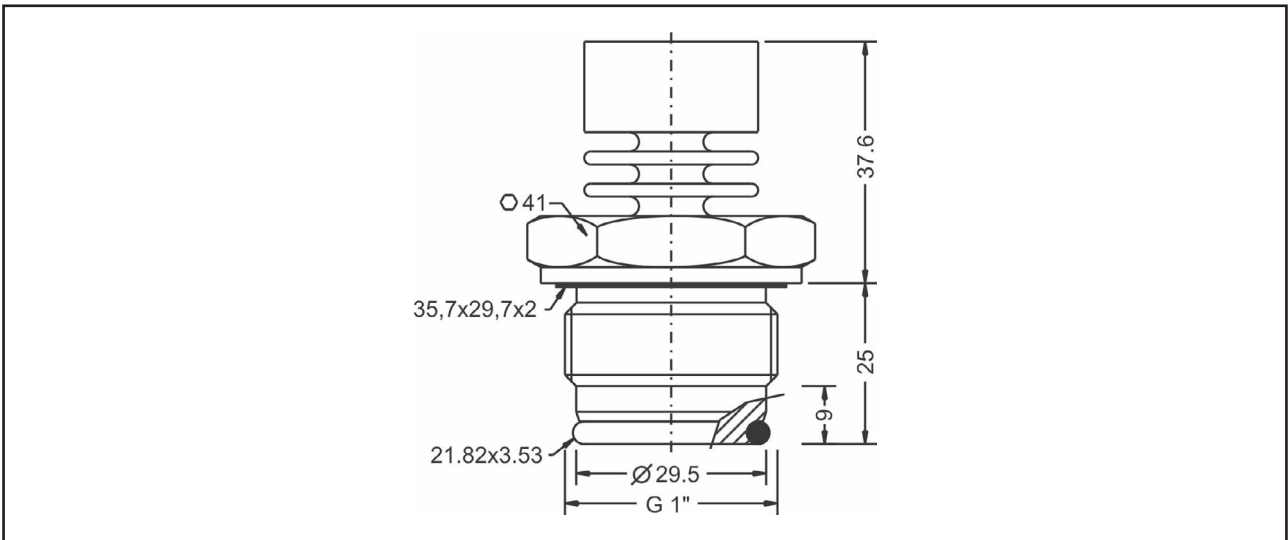

Type N - DN40 DIN 11851 - flush-mounted

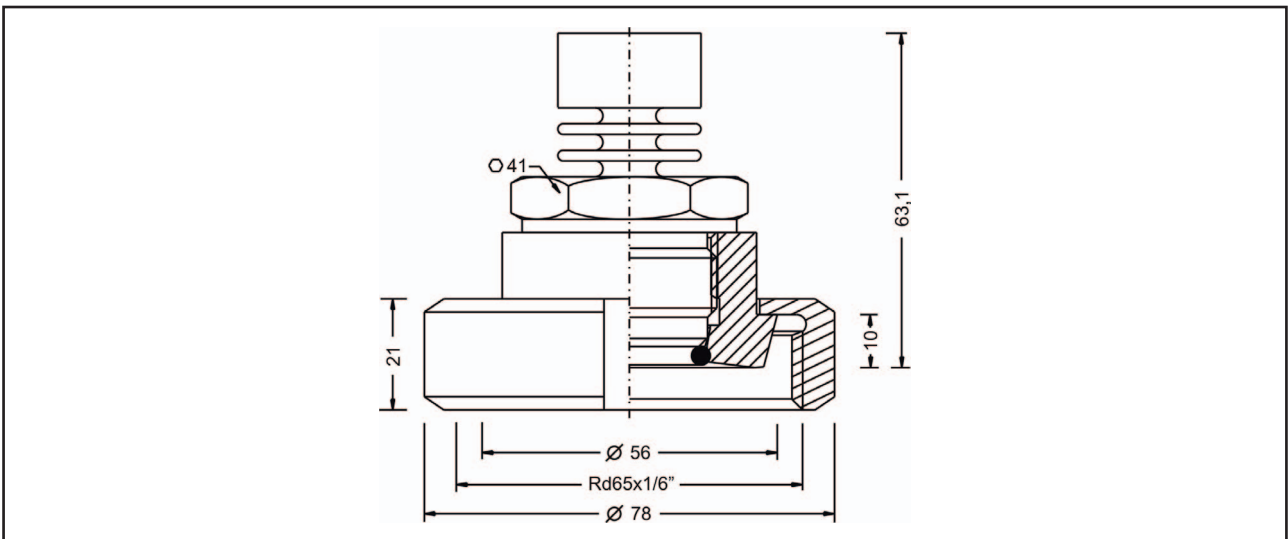

Type M - DN50 DIN 11851 - flush-mounted

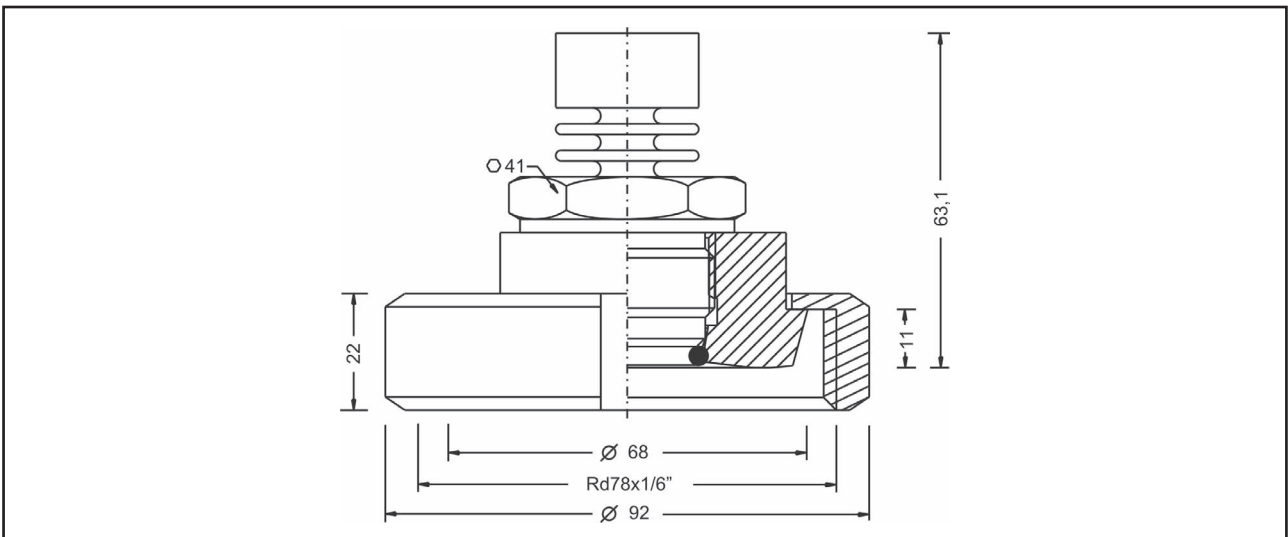

Type P - Varivent® N, Ø68 mm

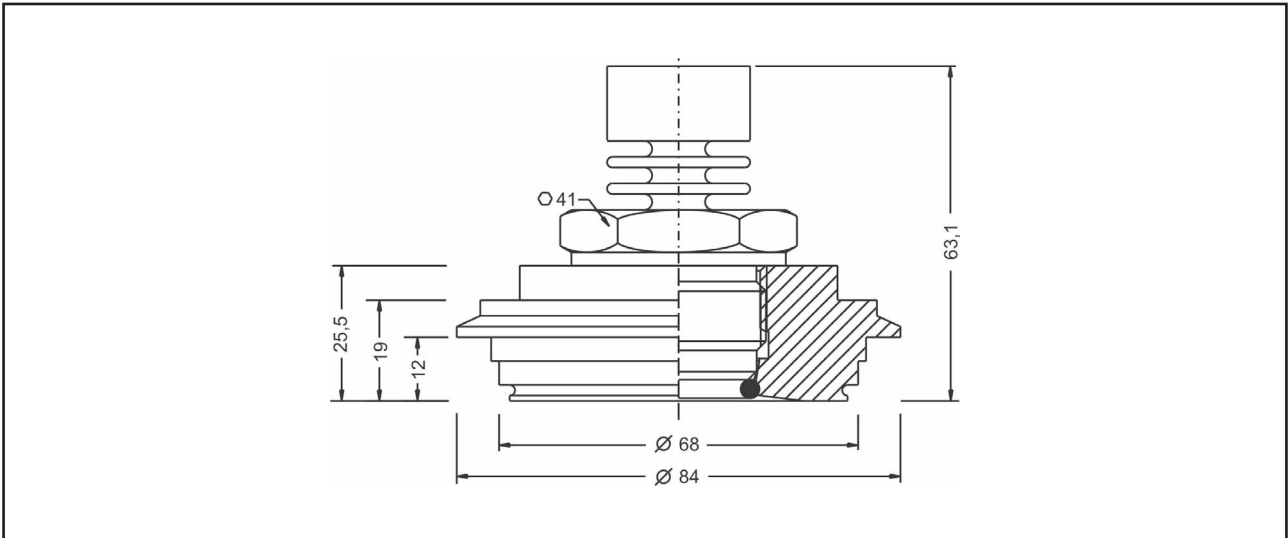

# Order Code

PL	<b>Type</b> Standard
M	<b>Measuring membrane - material / accuracy</b> (process wetted) Metal, strain gage-piezoresistive / 0,5%
5	<b>Process connection</b> G1" B, ISO 228-1, flush-mounted, radial O-ring, EHEDG conform
N	Milk tube DIN 11851, DN40
M	Milk tube DIN 11851, DN50
P	Varivent® N, Ø68 mm, DN40-125 (1½"-6")
1	<b>Material gaskets</b> (process wetted) FPM – fluorelastomere (Viton®)
3	EPDM – ethylene-propylene-dienmonomere - food applications
V	<b>Material process connection</b> (process wetted) Steel 1.4435/316L
C	<b>Material terminal enclosure</b> CrNi-steel
01	<b>Measuring range</b> 0..0,1 bar
02	0..0,25 bar
03	0..0,4 bar
04	0..0,6 bar
05	0..1 bar
07	0..2,5 bar
08	0..4 bar
09	0..6 bar
10	0..10 bar
11	0..16 bar
12	0..25 bar
16	-1..0 bar
17	-1..+1 bar
YY	Special measuring range (poss. higher deviation accuracy)
A	<b>Electronic - output</b> (others on request) 2x PNP
B	3-wire, signal 4...20mA, 1x PNP
C	3-wire, signal 4...20mA, 2x PNP
D	3-wire, signal 4...20mA, 2x PNP, Desina
0	<b>Process temperature</b> Standard, -20°C...+150°C
R	<b>Pressure type</b> Gauge pressure
A	Absolute pressure
S	<b>Electrical connection</b> Plug M12

<b>Precont</b>	PS				V	C					S
----------------	----	--	--	--	---	---	--	--	--	--	---

Installation material and connection cable are not enclosed in contents of delivery.

**ACS-CONTROL-SYSTEM**  
knowledge and systems

Your partner for measuring technology and automation



ACS-CONTROL-SYSTEM GmbH  
Lauterbachstr. 57  
D- 84307 Eggenfelden

Tel.: +49 (0) 8721/ 9668-0  
Fax: +49 (0) 8721/ 9668-30

[info@acs-controlsystem.de](mailto:info@acs-controlsystem.de)  
[www.acs-controlsystem.de](http://www.acs-controlsystem.de)