



fill level



water level



pressure



temperature



flow



visualization



signal converter



sensoric



Thermocont TK

Temperature transmitter

*Measurement of temperatures
in gases, vapors, liquids and dust*

*Technical manual
12.11*



Main features

Process temperature from -50°C to 150 °C

Screw-in thread or hygienic process connections

Long term stable temperature sensor platinum Pt100 class A – IEC 60751

Short response time

Optionally integrated evaluation electronic

- 2-wire with current signal 4...20 mA
- 2-wire with current signal 4...20 mA – programmable
- Accuracy $\leq 0,1K$ resp. 0,08%

You have purchased a high-grade and modern measuring device of ACS-CONTROL-SYSTEM GmbH.

We want to give thanks for your purchase and for your confidence to us.

The actual technical manual includes instructions for installation, electrical connection and inauguration, as well as the technical data of the device.

Modifications, that answer the purpose of the technical progress, are reserved by ACS-CONTROL-SYSTEM GmbH without prior notice.

If a question occurs, that can't be answered by the listed informations, please call on our technicians team in Eggenfelden Tel: +49 8721/ 9668-0 or info@acs-controlsystem.de

All rights reserved

Index

Application	4
Function	4
Safety notes	5
Installation	6
Installation place	6
Process and environmental temperature	7
Installation notes	7
Electrical connection	8
Potential equalization - earthing	8
Connection cable	8
Supply voltage	8
Load resistor	8
Connection scheme	9
Operation	10
Maintenance	10
Repair	10
Technical Data	11
Auxiliary power supply	11
Output Signal Pt100	11
Output Signal 4...20mA	11
Measuring accuracy	12
Process conditions	13
Environmental conditions	13
Materials - process wetted	13
Materials - not process wetted	13
Dimension drawings	14
Terminal enclosure	14
Neck tube	15
Process connection	15
Probe	18
Order Code	19

Application

The device is an electronic temperature transmitter for continuous measuring of temperatures in gases, vapors, liquids and dusts within closed container or pipes.

The use of a long-term stable platinum temperature sensor – Pt100 – allows a precise measurement of temperatures in nearly all fields of industry, especially at hygienic applications.

Function

The device is mounted in the wall of the container or of the pipe.

The sensor tube is the junction point with the applied medium and is in direct contact with it. Inside, the temperature sensor is installed, that is used for the measurement of the temperature and for its conversion into an electrical signal.

The measurement of the process temperature is made by a resistive temperature sensor element Pt100 of class A. This allows a precise and long term stable temperature measurement.

The Pt100 sensor element is alternatively directly connected per 4-wire to the connector plug or connected internally to the optionally integrated 2-wire evaluation electronic (4...20mA).

The temperature signal is converted into an electrical signal and converted by the optionally integrated evaluation electronic into a temperature proportional current signal 4...20 mA.

The programmable version of the optionally integrated 2-wire evaluation electronic allows an easy user sided adaption of the temperature transmitter to the requirements of the application.

Safety notes

Each person that is engaged with inauguration and operation of this device, must have read and understood this technical manual and especially the safety notes.

Installation, electrical connection, inauguration and operation of the device must be made by a qualified employee according to the informations in this technical manual and the relevant standards and rules.

The device may only be used within the permitted operation limits that are listed in this technical manual.

Every use besides these limits as agreed can lead to serious dangers.

The materials of the device must be chosen resp. checked for compatibility with the respective application requirements (contacting materials, process temperature). An unsuitable material can lead to damage, abnormal behavior or destruction of the device and to the resulting dangers.

The sensors may not be used as sole device for prevention of dangerous conditions in machines and plants.

This measuring device meets article 3 (3) of the EC directive 97/23/EC (pressure equipment device directive) and is designed and produced in good engineer practice.

The device meets the legal requirements of all relevant EC directives. 

Using the device in a manner that does not fall within the scope of its intended use, disregarding this instruction, using under-qualified personnel, or making unauthorized alterations releases the manufacturer from liability for any resulting damage. This renders the manufacturer's warranty null and void.

Installation

The correct function of the device within the specific technical data can only be guaranteed, if the permitted process and environmental temperatures (see chapter „Technical data“) will not be exceeded.

Installation place

The choice of the place of installation of the sensor and the length of the sensor tube are of considerable importance for the quality and the reliability of the measuring results.

If the sensor isn't installed deeply enough, an error in the measured temperature can occur because of the different process flow temperature at the pipeline wall and the heat transfer along the sensor tube.

The appearance of the error should not be ignored if a considerable difference between process temperature and environmental temperature exists.

Thus it is suggested to use an installation length of at least 80...100 mm.

The shorter the installation length, the greater is the deviation against the real medium temperature caused by the heat transfer.

The following general recommendations can be applied as approximately guideline:

- In liquids, the sensor tube length should be 5...6 times greater than the diameter of the sensor tube plus the sensitive length of 50 mm.
- In steam, air and gases, the sensor tube length should be 10...15 times greater than the diameter of the sensor tube plus the sensitive length of 50 mm.

In pipelines with small diameter the tip of the sensor tube should reach the axis line, that means the middle of the pipeline, and if possible additionally a little more.

By isolating the external parts of the sensor, the effect caused by too low installation depth, can be reduced.

An additional solution for optimizing the measurement quality of small formatted pipelines could be the installation of the sensor tube diagonal to the pipeline longitudinal axis or the installation of the sensor tube in the pipeline arc.

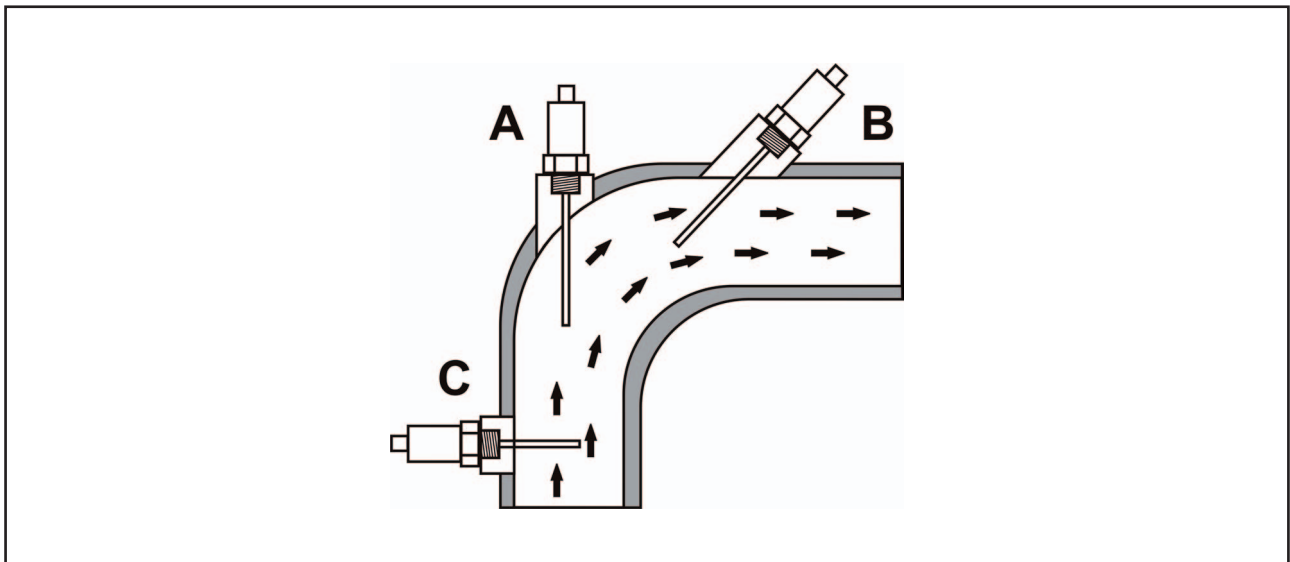

- A) In the pipe arc against the flow direction
- B) In small pipes diagonal against the flow direction
- C) Vertical to the flow direction

At a horizontal installation, especially in hygienic applications, the probe should be installed with a decline against the horizontal of minimum 3°, to ensure a self-emptying.

Process and environmental temperature

At high process temperatures a heat transfer to the terminal housing can be reduced by isolation of the medium carrying part of the plant or by the use of a neck tube.

Neck tube

The neck tube is used to decouple the temperatures between medium and the connection housing in order to reduce the temperature at the connection housing.

By using a neck tube at extreme process temperatures it can be achieved, that the permitted environmental temperature range in the area of the connection housing will not be exceeded.

The length of the needed neck tube depends on the height of the process temperature and the respective installation situation.

Installation notes

Drive the system pressure free prior installation resp. deinstallation of the sensor.

Be also sure that no medium is flowing in the system. At extreme system or medium temperatures there could exist serious dangers.

The screw-in of the thread process connection by using the terminal housing, the connection plug resp. the connection cable is not permitted.

The tightening of the thread process connection may only be done at the hexagon by a suitable spanner and with the maximum permitted torque strength.

The maximum permitted torque strength is 100 Nm.

Electrical connection

The electrical connection of the device must be carried out according to the respective country specific standards.

Incorrect installation or adjustment could cause applicationally conditioned risks.

Potential equalization - earthing

The device must be grounded.

The earthing can be carried out by the metallic process connection.

Connection cable

Use only shielded signal and measurement wires and install these wires separated from power leading wires.

The cable shield of a connected cable must be grounded.

Supply voltage

The voltage applied to the terminal contacts may not exceed the maximum permitted supply voltage to avoid damage of the electronic.

The maximum permitted supply voltage range at the respective version is:

2-wire / signal 4...20mA	10...35V _{DC}
--------------------------	------------------------

All connections are reverse polarity protected.

Load resistor

Signal 4...20 mA

A load resistor, e.g. the measuring shunt of an evaluation device, requires a minimum supply voltage. Dependent on the connected supply voltage, it results in a maximum value for this resistor, where a correct function is still possible.

This resistor can be calculated by the following term:

$$R_{Lmax} = (U_s - U_{Smin}) / 20mA$$

R_{Lmax} = maximum load resistor

U_s = connected supply voltage

U_{Smin} = minimum supply voltage

Load resistor characteristic

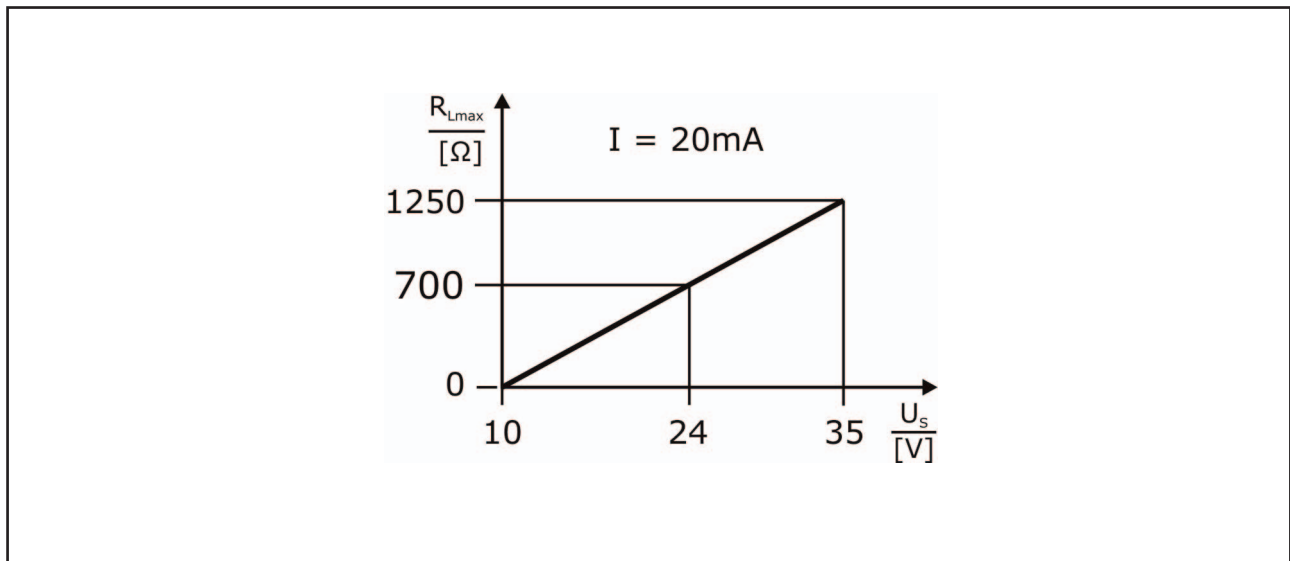

Connection scheme

2-wire / signal 4...20 mA / type A/E

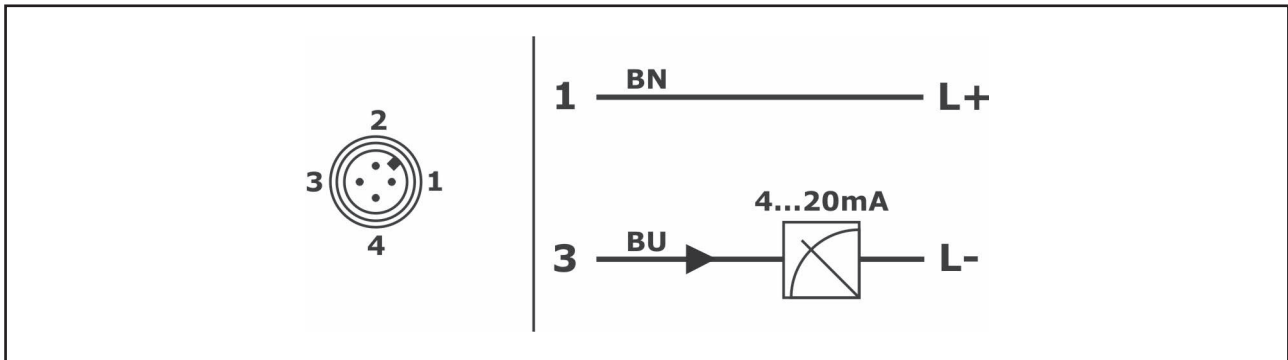

Conductor color standard connection cable M12:

BN = brown, BU = blue

The connection cable is not enclosed in the delivery contents.

4-wire / Pt100 / type B

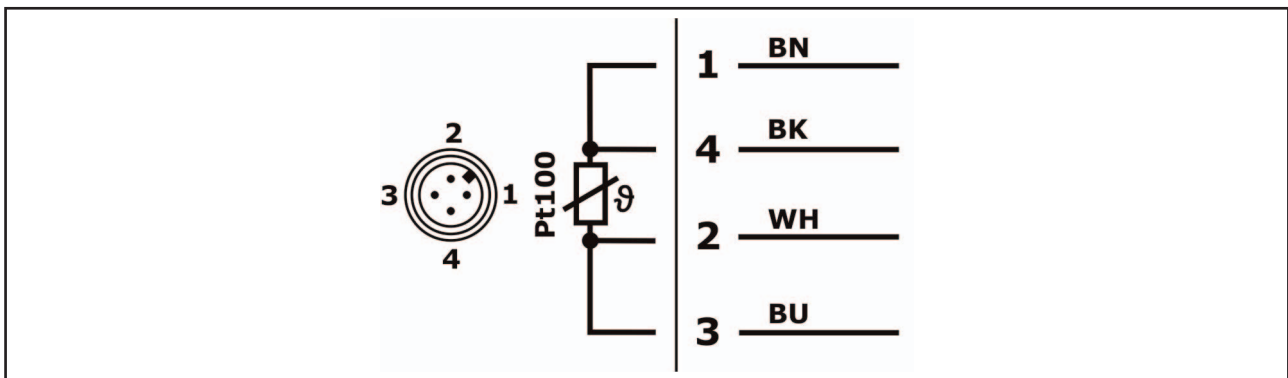

Conductor color standard connection cable M12:

BN = brown, WH = white, BU = blue, BK = black

The connection cable is not enclosed in the delivery contents.

4-wire / Pt100 / type C

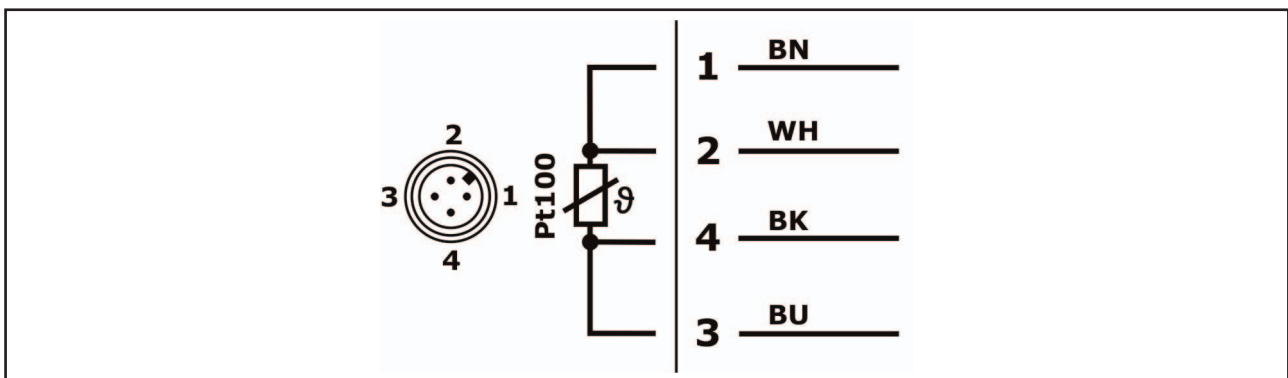

Conductor color standard connection cable M12:

BN = brown, WH = white, BU = blue, BK = black

The connection cable is not enclosed in the delivery contents.

Operation

An operation provided by user is not designated.

Maintenance

The device is free of maintenance.

Repair

A repair may only be carried out by the manufacturer.

If the device must be sent back for repair, the following informations must be enclosed:

- An exact description of the application.
- The chemical and physical characteristics of the product.
- A short description of the occurred error.

Before returning the device for repair, the following measures must be proceeded:

- All adhesive product residues must be removed. This is especially important, if the product is unhealthily, e.g. caustic, toxic, carcinogenic, radioactive etc.
- A returning must be refrained, if it is not possible by 100% to remove the unhealthily product completely, because e.g. it is penetrate into cracks or is diffused through plastic.

Technical Data

Auxiliary power supply

Supply voltage U_s	<u>2-wire 4...20 mA / 2-wire 4...20 mA - programmable</u> 10..35 V _{DC} , reverse polarity protected
Residual ripple U_{pp}	<u>2-wire 4...20 mA / 2-wire 4...20 mA - programmable</u> $\leq 2 V_{pp} / U_{Smin} \leq U_s \leq U_{Smax}$
Supply current I_{In}	<u>2-wire 4...20 mA</u> ≤ 30 mA <u>2-wire 4...20 mA - programmable</u> ≤ 23 mA

Output Signal Pt100

Function	Pt100 class A, 4-wire
Supply current	≤ 1 mA
Step response time T_{90}	≤ 3 s

Output Signal 4...20mA

Operating range I_{Out}	<u>2-wire 4...20 mA</u> $\leq 3,8$ mA ... $\geq 20,5$ mA <u>2-wire 4...20 mA - programmable</u> $\leq 3,8$ mA ... $\geq 20,5$ mA $\geq 20,5$ mA ... $\leq 3,8$ mA
Error signal	$\leq 3,6$ mA resp. ≥ 21 mA (sensor break, sensor short circuit)
Permitted load R_l	$\leq (U_s - 10 V) / 20mA$
Step response time T_{90}	<u>2-wire 4...20 mA</u> $\leq 0,1$ s <u>2-wire 4...20 mA - programmable</u> ≤ 1 s
Start-up time t_{On}	<u>2-wire 4...20 mA</u> $\leq 0,1$ s <u>2-wire 4...20 mA - programmable</u> ≤ 2 s

Measuring accuracy

Reference conditions	EN/IEC 60770-1 resp. EN/IEC 61003-1
	T = 25 °C, relative humidity 45...75 %, environmental air pressure 860..1060 kPa
Calibration position	Vertical, process connection bottom side
Supply voltage	24 V _{DC}
Warm-up time	≤ 240 s
Measurand error ^{5) 12)}	<p><u>Pt100</u> $\leq \pm(0,15K + 0,002 * T)$ T = Numerical value of temperature in °C, no leading sign</p> <p><u>Transmitter</u> $\leq \pm 0,1K$ resp. $\pm 0,08\%$ FS ²⁾ – larger value applies</p> <p><u>Pt100 + Transmitter</u> $\leq \pm(0,25K + 0,002 * T)$ T = Numerical value of temperature in °C, no leading sign</p>
Influence of supply voltage	<p><u>2-wire 4...20 mA</u> $\leq \pm 0,002\%$ FS ²⁾ / 1V</p> <p><u>2-wire 4...20 mA - programmable</u> $\leq \pm 0,01\%$ FS ²⁾ / 1V</p>
Load influence	<p><u>2-wire 4...20 mA / 2-wire 4...20 mA - programmable</u> $\leq \pm 0,02\%$ FS ²⁾ / 100R</p>
Long term drift ¹²⁾	<p><u>2-wire 4...20 mA / 2-wire 4...20 mA - programmable</u> $\leq \pm 0,1K$ resp. $0,05\%$ FS ²⁾ / year - not cumulative</p>
Temperature deviation ¹²⁾	<p><u>2-wire 4...20 mA</u> $T_k^{4)} \leq \pm 0,05\%$ FS ²⁾ / 10 K</p> <p><u>2-wire 4...20 mA - programmable</u> $T_k^{4)} = \pm(15 \text{ ppm/K} * (\text{full scale value of measuring range} + 200) + 50 \text{ ppm/K} * \text{set measuring range}) * \Delta \vartheta$</p>

²⁾ Referring to nominal measuring span resp. full scale (FS)

⁴⁾ T_k = Temperature coefficient

⁵⁾ Limit value adjustment acc. to EN/IEC 60770-1

¹²⁾ Higher values for special measuring range

Process conditions

Process temperature	-50°C...+150°C <i>2-wire 4...20 mA / 2-wire 4...20 mA - programmable with neck tube (L2 ≥ 50mm)</i> -50°C...+150°C <u>Limitation</u> <i>2-wire 4...20 mA / 2-wire 4...20 mA - programmable without neck tube</i> -50°C... ≤ +135°C (T _A -40°C... ≤ +40°C) -50°C... ≤ +120°C (T _A -40°C... ≤ +60°C) -50°C... ≤ +100°C (T _A -40°C... ≤ +85°C)
Process pressure	≤ 100 bar (L1 ≤ 200 mm) <u>Limitation</u> depending on process connection
Flow velocity	≤ 40 m/s (water / L1 ≤ 50 mm) ≤ 10 m/s (water / L1 ≤ 100 mm) ≤ 4 m/s (water / L1 ≤ 150 mm) ≤ 2 m/s (water / L1 ≤ 200mm)

Environmental conditions

Environmental temperature	-40°C...+85°C
Protection	IP67 (EN/IEC 60529)
Climatic classification	4K4H [-20...+55°C / 4...100%] (EN/IEC 60721-3-4)
Shock classification	4 g [2 - 150 Hz] (EN/IEC 60068-2-6)
Vibration classification	4 g [2 - 150 Hz] (EN/IEC 60068-2-6)
EM compatibility	Operation device class B / Industrial range (EN/IEC 61326)
Weight	Depends on variant e.g. D1=Ø4 mm / L1=100 mm / G ½" - ISO 228-1 <u>Pt100</u> 0,115 kg <i>2-wire 4...20 mA / 2-wire 4...20 mA - programmable</i> 0,145 kg

Materials - process wetted

Probe	Steel 1.4571/316Ti
Process connection	Steel 1.4571/316Ti
Surface quality	Ra < 0,8µm

Materials - not process wetted

Terminal enclosure	CrNi-steel
Electrical connection part	Device plug PUR

Dimension drawings

Terminal enclosure

Electronic output type A / E - 2-wire, signal 4...20mA

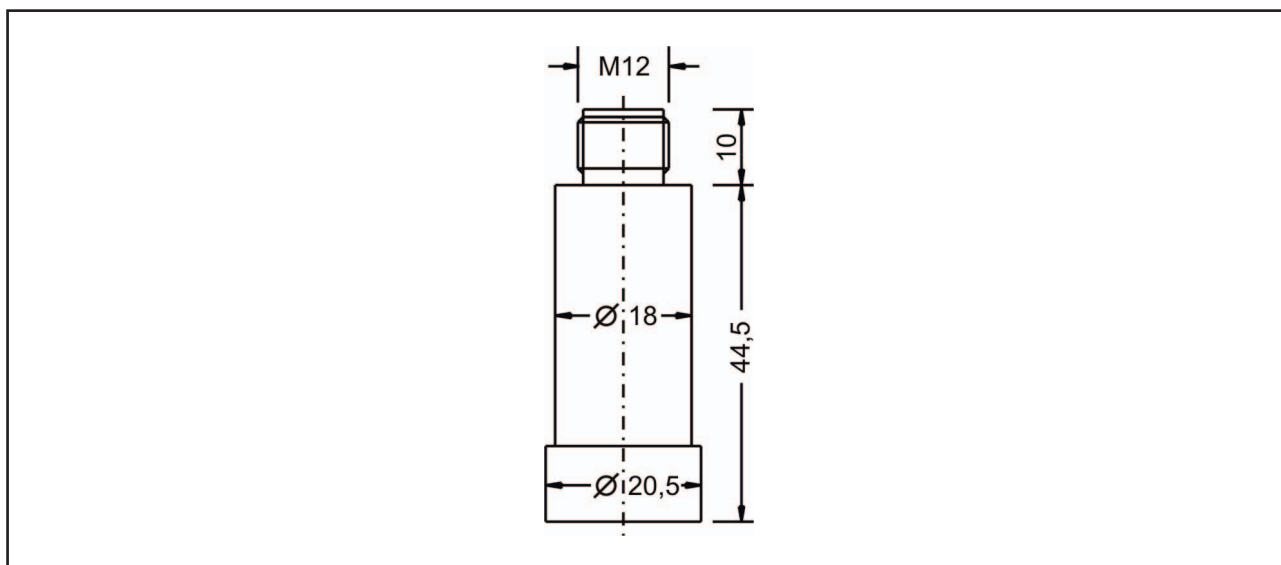

Electronic output type B / C - Pt100, 4-wire

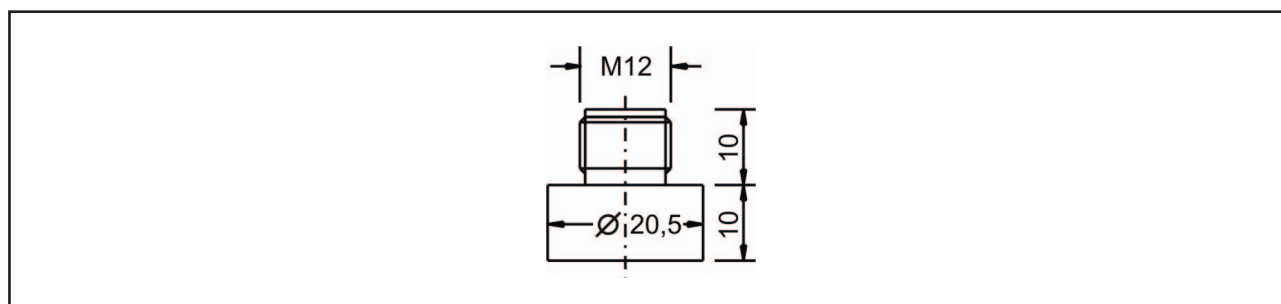

Neck tube

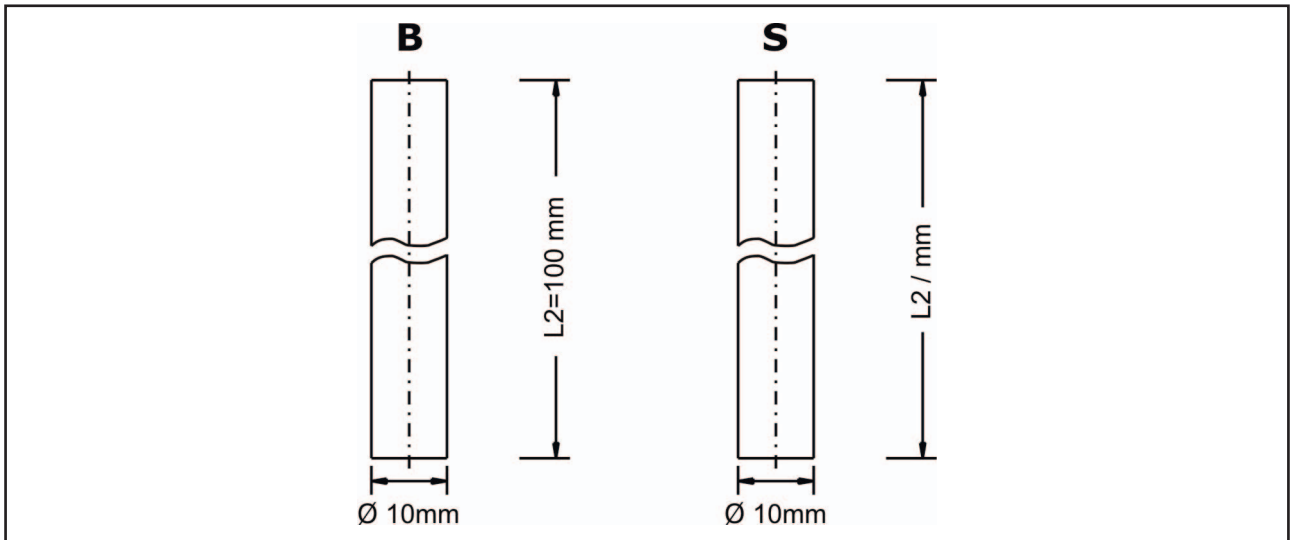

Process connection

Type 1 - G 1/2" ISO 228-1

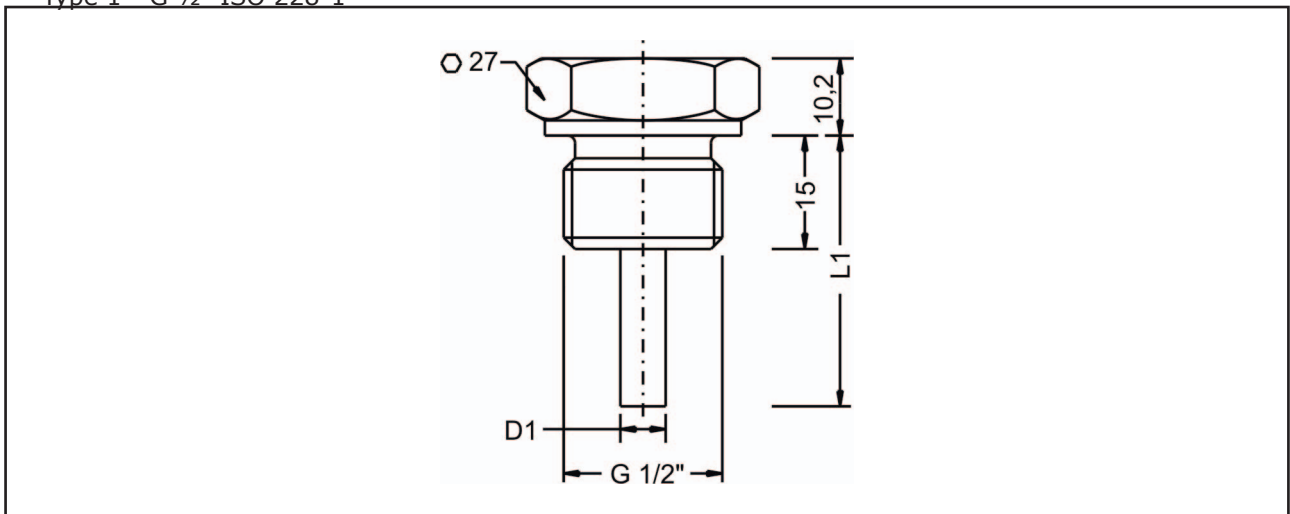

Type 2 - without (for slide sleeve)

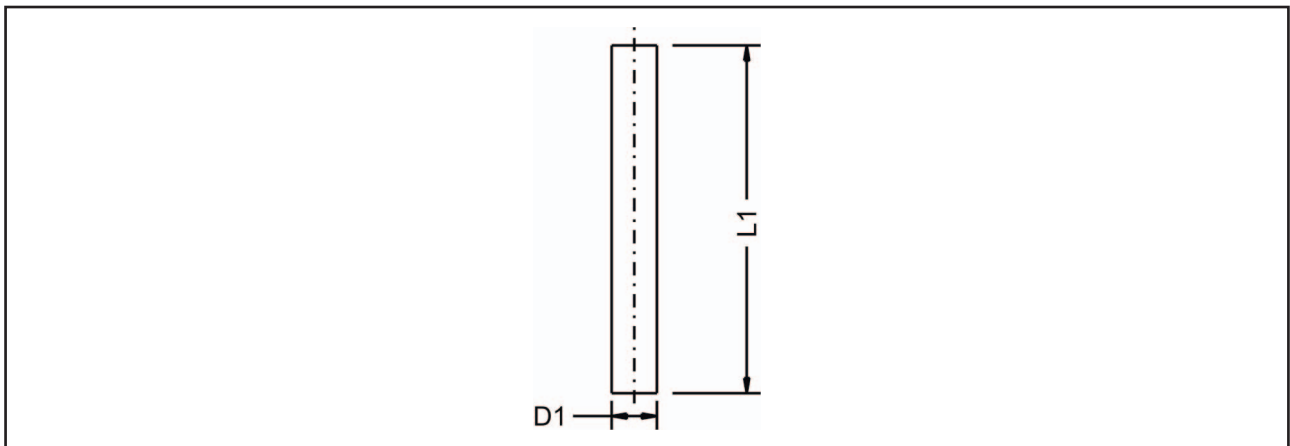

Type M / N / O - DIN 11851

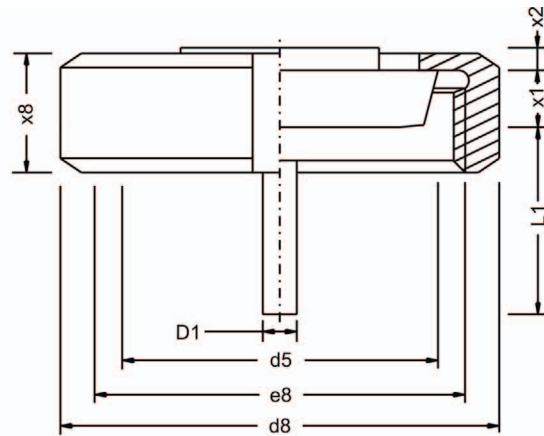

	DN	PN	d5	x1	x2	d8	x8	e8
O	25	40	44	10	4	63	21	Rd52x1/6"
N	40	40	56	10	4	78	21	Rd65x1/6"
M	50	40	68	11	3	92	22	Rd78x1/6"

Type R - Varivent®

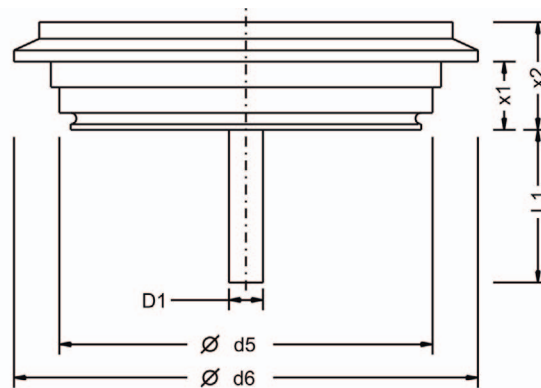

	DN	PN	d5	d6	x1	x2
R	25-32	40	F 50	66	12	19
P	40-125	40	N 68	84	12	19

Type L - DRD DN50, Ø65 mm

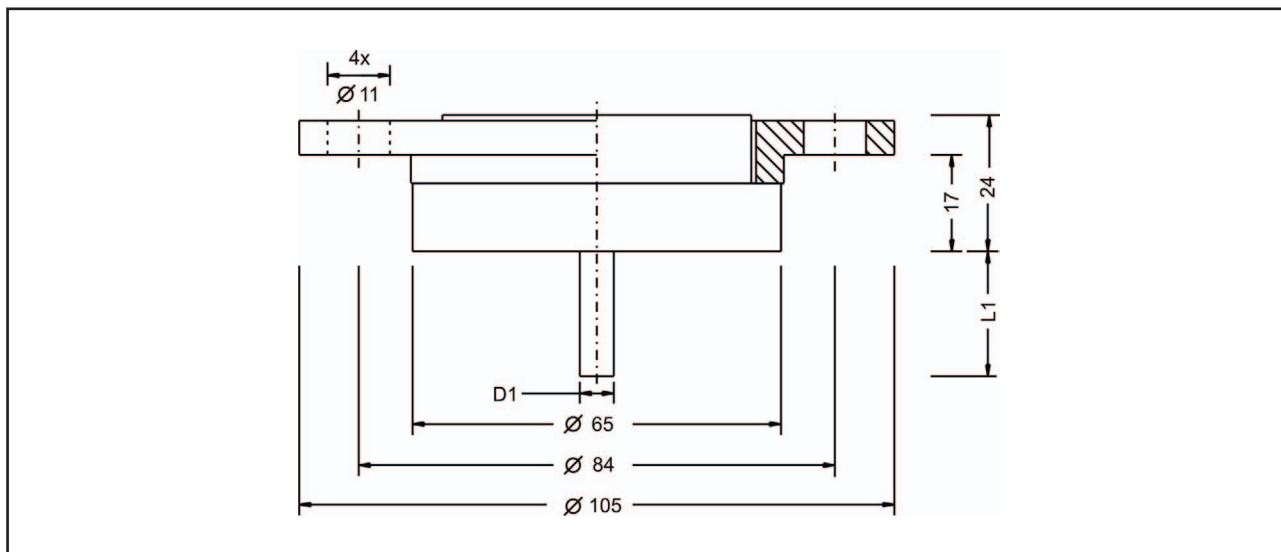

Type G - Flange DIN EN 1092-1, A (B - DIN 2527), DN50

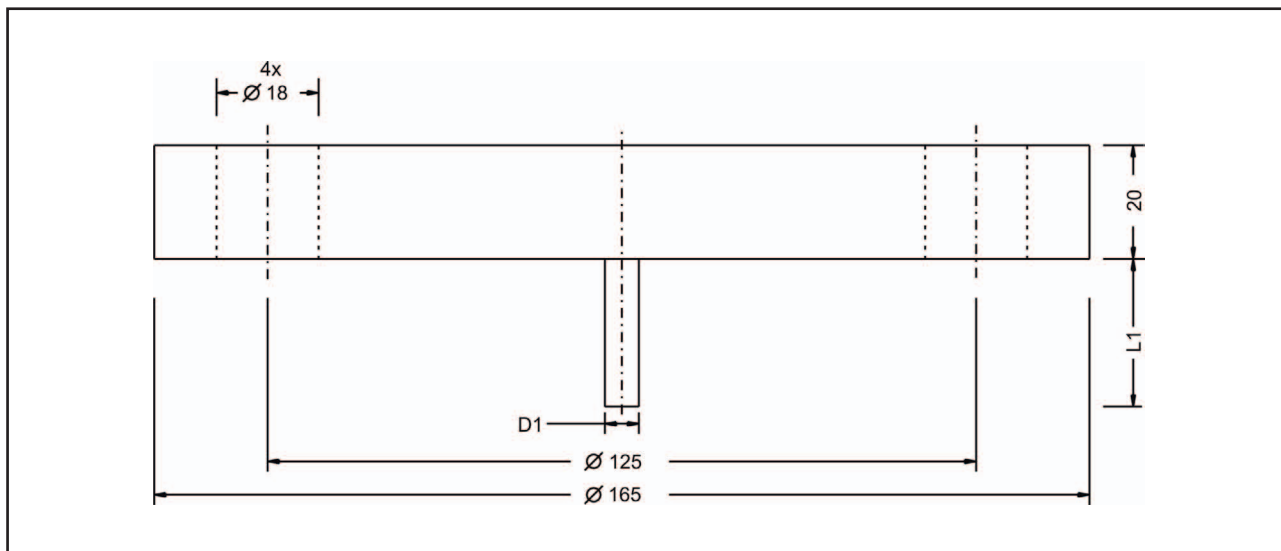

Type T - Clamp ISO 2852 DN51 (2") / DIN 32676 DN50

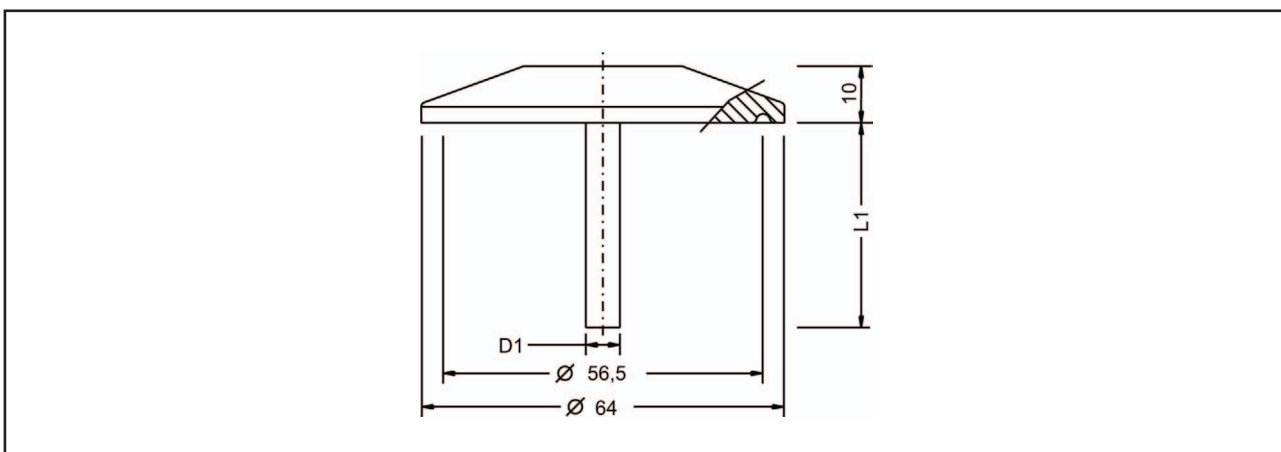

Probe

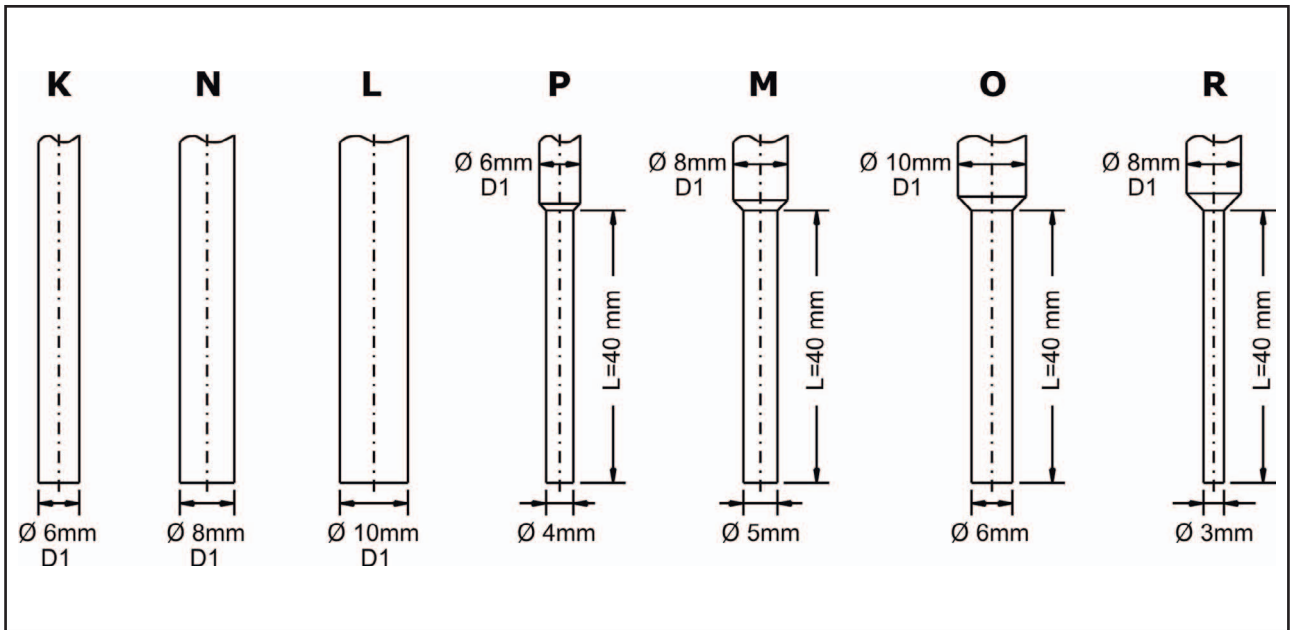

Order Code

TK	Type Standard
K	Construction form compact - cylindrical
A	Sensor / class Pt100 class A - IEC 60751
1	Process connection G½" B, ISO 228-1
2	without
M	Milk tube DIN 11851, DN50, PN40
N	Milk tube DIN 11851, DN40, PN40
O	Milk tube DIN 11851, DN25, PN40
R	Varivent® F, Ø50 mm, DN25-32, PN 40
P	Varivent® N, Ø68 mm, DN40-125, PN 40
L	DRD DN50, Ø65 mm, PN25
G	Flange DIN EN 1092-1, A (B - DIN 2527), DN50, PN10-40
T	Tri-Clamp 2"/DN51, PN16/40
S	others
K	Material process connection/probe (process wetted) - probe diameter D1 Steel 1.4571/316TI - Ø6 mm
N	Steel 1.4571/316TI - Ø8 mm
L	Steel 1.4571/316TI - Ø10 mm
P	Steel 1.4571/316TI - Ø6 mm - reduced tip Ø4 mm/L=40 mm
M	Steel 1.4571/316TI - Ø8 mm - reduced tip Ø5 mm/L=40 mm
O	Steel 1.4571/316TI - Ø10 mm - reduced tip Ø6 mm/L=40 mm
R	Steel 1.4571/316TI - Ø8 mm - reduced tip Ø3 mm/L=40 mm
S	others
A	Neck tube without
B	Neck tube L2=100mm
S	Neck tube L2/mm to choice
C	Material terminal enclosure CrNi-steel
S	Electrical connection Plug M12
A	Electronic - output 2-wire, signal 4...20mA
B	Pt100, 4-wire, connection B
C	Pt100, 4-wire, connection C
E	2-wire, signal 4...20mA, programmable
BA	Measuring range -50...+100°C
CA	-40...+60°C
DA	-30...+60°C
DB	-30...+150°C
DC	-30...+70°C
EA	-20...+20°C
EB	-20...+60°C
EN	-10...+40°C
FC	0...+50°C
FE	0...+100°C
FG	0...+150°C
00	Pt100, 4-Leiter
XX	Special measuring range (poss. higher deviation accuracy)
B	Sensor length L1 / mm 50 mm
C	100 mm
D	150 mm
E	200 mm
Y	others

Thermocont TK K A C S

Installation material and connection cable are not enclosed in contents of delivery.

ACS-CONTROL-SYSTEM
knowledge and systems

Your partner for measuring technology and automation



ACS-CONTROL-SYSTEM GmbH
Lauterbachstr. 57
D- 84307 Eggenfelden

Tel.: +49 (0) 8721/ 9668-0
Fax: +49 (0) 8721/ 9668-30

info@acs-controlsystem.de
www.acs-controlsystem.de