



VISUALIZED DIGITAL COUNTER WITH ONE SET POINT

Type:
GCM51
Change 07/2002

VISUALIZED DIGITAL 5 DIGITS COUNTER, WITH INPUT FOR SINGLE DIRECTIONAL COUNTS, ONE SET POINT OF INTERVENTION AND IMPULSES TOTALIZER.

The **GCM 51** counter finds application where there is the necessity to visualize and to control, through one programmable set point, mono-directional counts deriving from electromechanical and logical contacts, proximity and encoder.



MAIN FEATURES

- Frontal keyboard in polycarbonate (antiscratch, antioil, antacid).
- IP65 protection degree
- Accessible parameters with key software
- Removable terminals connection.
- Execution DIN 48 x 48.
- Recessed assembly.
- Special retaining brackets.

PROGRAMMABLE PARAMETERS

- One set points
- Reset time
- 2 conversion factors of the impulses
- Input (Slow / Fast)
- Count (Up / Down / Superior)
- Memory
- Reset key
- Decimal Point

TECHNICAL FEATURES

- | | |
|---|--|
| • POWER SUPPLY IN ALTERNATING CURRENT | : Single power 24 - 110 - 230 Vac (50 / 60 Hz). |
| • POWER SUPPLY IN CONTINUUM CURRENT | : Single power 24 Vdc (12 Vdc option) |
| • POWER SUPPLY TOLERANCE | : +10% - 15%. |
| • ABSORPTION | : 2 W - 3 VA. |
| • OPERATING TEMPERATURE | : -5 °C + 55 °C. |
| • CLIMATIC CONDITIONS | : U.R. 95 % at 40 °C (without condensate). |
| • COUNTER AND TOTALIZER VISUALIZATION | : 5 digits, 7,5 mm high |
| • MULTIPLICATION FACTOR M1 OF THE IMPULSES IN INPUT | : Programmable from 0,00001 to 9,99999. |
| • MULTIPLICATION FACTOR M2 OF THE IMPULSES IN INPUT | : Programmable from 1 to 99. |
| • INPUT TYPE | : Suitable for electromechanical contact and NPN or PNP signals |
| • COUNT FREQUENCY FOR LOGICAL SIGNALS | : Up to 15 KHz with Duty Cycle=50%. |
| • MINIMUM TIME FOR COUNT IMPULSES | : 0,25 mSec. |
| • CUT FREQUENCY FOR ELECTROMECHANICAL INPUTS | : About 30 Hz. |
| • AUXILIARY INPUTS POWER SUPPLY | : 12 Vdc - 100 mA available on terminals. |
| • COMMAND INPUTS | : 1 Counter Reset - 1 Inhibit. |
| • OUTPUTS | : 1 relay with operating contacts - capacity 2A - 250Vac. |
| • RELAY RESET | : Manual or automatic with excitation time from 0,1 to 99,9 sec. |
| • PROGRAMMED DATA MEMORY | : static (no battery) |

DESCRIPTION OF THE FRONTAL KEYBOARD

 **WHITE**

The key '**LEFT ARROW**' in normal operating phase visualizes, blinking, all the programmings executed without the limitation of the insertion code. The time of scansion of the programmings is given from the pressure of the same key. It exits automatically from this phase after 5 sec of the last pressure of the same key.
In programming phase it moves the cursor of the figure towards left of a step, than at the beginning it is on the right side first one on the. At the end it resumes from the first one to right.

 **WHITE**

The key '**UP ARROW**' in normal operating phase visualizes the totalizer of impulses.
In programming phase it increases the value of the blinking figure.

 **BLUE**

The key '**PRG**' pressed for 2 sec. allows to enter in the programming phase, visualizing on display C.0000.
In the programming phase, pressing key 'PRG' impulsively, it exits from the programming phase. The instrument exits automatically from the programming phase, 60 sec. after the pressure of the last key.

 **GREEN**

The key '**ENT/RES**' in normal phase of counting has the 'RESET' function, with the modalities to it attributed in the programming phase.
In programming phase it confirms and memorizes the visualized data and passes to the successive function. If it has arrived to list end it resumes from the beginning.

INPUTS / OUTPUTS DESCRIPTION E SERIES

AC POWER SUPPLY
(inputs 1-2)

AC Power Supply Input of the instrument; it can be to 24 - 110 - 230 VAC in according to demand.

DC POWER SUPPLY
(inputs 3-4)

DC Power Supply Input of the instrument; input 3 (-), input 4 (+).

12 VDC - 100mA
(inputs 12-13)

12 VDC - 100 mA auxiliary Power Supply that the instrument supply to feed the Encoder and proximity amplified.

PRI
(input 10)

Input used for the polarization of the count and command inputs : connecting the PRI output to input 13 it configures the instrument in Negative logic (NPN), connecting the PRI output to input 12 it configures the instrument in Positive logic (PNP).

INPUT
(input 11)

Input of count adapted for electromechanical and logical contacts, encoder and 3 wires proximity amplified, configurable in Positive (PNP) and Negative (NPN) logic through PRI input (10).

RESET
input 7)

Input of RESET that executes the reset of the visualized count showed on display at the moment of its activation.

INHIBIT
(input 8)

Input of count inhibition: when activated it blocks the count of the normal counter and the totalizer.

RL1
(inputs 5 - 6 - 9)

Output of Relay 1, connected to the operation of the Set Point S1. The Common, Normally Open and Normally Close contacts are available.

INPUTS / OUTPUTS DESCRIPTION Z SERIES

AC/DC POWER SUPPLY
(inputs 2 - 10)

AC or DC Power Supply Input of the instrument; it can be to 24 - 110 - 230 VAC or 12 - 24 VDC in according to demand.

12 VDC - 100mA
(inputs 7 - 8)

12 VDC - 100 mA auxiliary Power Supply that the instrument supply to feed the Encoder and proximity amplified.

PRI
(input 9)

Input used for the polarization of the count and command inputs : connecting the PRI output to input 3 it configures the instrument in Negative logic (NPN), connecting the PRI output to input 4 it configures the instrument in Positive logic (PNP).

INPUT
(input 5)

Input of count adapted for electromechanical and logical contacts, encoder and 3 wires proximity amplified, configurable in Positive (PNP) and Negative (NPN) logic through PRI input (9).

RESET
(input 6)

Input of RESET that executes the reset of the visualized count showed on display at the moment of its activation.

RL1
(inputs 1 - 3 - 4)

Output of Relay 1, connected to the operation of the Set Point S1. The Common, Normally Open and Normally Close contacts are available.

DESCRIPTION OF THE LED'S OPERATION

LED 1

It comes activated to the reaching of the Set Points S1.

SET POINTS PROGRAMMING

For SET POINTS programming access, proceed as follow:

- Press key 'PRG' in impulsive mode; on display appears:

S 1
99999

S.1 = SET POINT 1, main Set Point, programmable between 0 and 99999. If programmed = 0 the Set Point is excluded and the instrument works like a totalizer and predisposes the count in UP mode.

Key **ENT** confirms the data. In order to exit the programming, press key **PRG**.

PROGRAMMING OF THE OPERATION PARAMETERS

The programmable parameters are divided in two groups and protect with a 4 figures code.

In order to approach the programming, proceed in the following way:

- Press key **PRG** for about 2 sec. On the display appears:

Cod
0000

GROUP 1 : in order to approach the parameters of group 1, insert code **2357** and press **ENT**

n 1
10000

5 digits multiplier , programmable from 0,1 to 9,9999. This parameter allows to convert the number of the input impulses, showing them on the display in an other format. If it programmed = 0 it comes reprogrammed automatically to 1. If a value lower than 1 is inserted, it obtains the division of the impulses. Es. I want to divide by 25 the impulses in input; calculation 1 : 25 = 0.04.

Attention: the variation of the value of the multiplying modifies automatically the value of the count and the totalizer.

n 2 10

2 digits multiplier, programmable from 1 to 99. This parameter allows to convert the number of the input impulses, showing them on the display in an other format. If it programmed = 0 it comes reprogrammed automatically to 1.

Attention: the variation of the value of the multiplying modifies automatically the value of the count and the totalizer.

t.r. 99.9

t.r. = Time of Automatic Reset, programmable from 0.0 to 99.9 sec. This parameter allows to make to work the instrument in **automatic** mode. When the count arrives to the value of S.1, it automatically resets the count, excites the RL1 relay and it resumes to count without to lose the impulses. The RL1 relay remains excited for the set up time in **t.r.** If the time of reset is programmed = 0 (0.0) the instrument gets ready to works in **manual** mode.

Particular cases: if the set up time **t.r.** is bigger than the time employed to the count to arrive to the values of S.1, the relay will never come unactivated.

In F
In S

Input Fast - Slow.

This programming allows to predispose the input of count to read signals coming from electromechanical contacts (relais, switches etc.) that introduces false signals, or from logical signals like proximity, encoder, transistor etc.)

In = F. predisposes the instrument in order to read logical signals up to 15 KHz.

In = S. predisposes the instrument in order to read electromechanical contacts up to 30 Hz.

Cn UP
Cn dn
Cn Sp.

Count UP / DOWN / Superior.

Count = Up: the counter gets ready to visualize the count in increasing way (UP), starting from zero up to the programmed value of set point. To ended count it behave in Manual or Automatic mode like programmed in **t.r.**

Count = dn: the counter gets ready to visualize the count in decreasing way (DOWN), starting from the programmed value of set point to zero. To ended count it behave in Manual or Automatic mode like programmed in **t.r.**

Count = Sp: the counter gets ready to visualize the count in increasing way, starting from zero up to the programmed value of set point. To the attainment of the value of programmed set point it behave as in the Manual count and continues to count the impulses in input.

PROGRAMMING OF THE OPERATION PARAMETERS

The programmable parameters are divided in two groups and protect with a 4 figures code.

In order to approach the programming, proceed in the following way:

- Press key **PRG** for about 2 sec. On the display appears:

Cod
0000

GROUP 2 : in order to approach the parameters of **group 1**, insert code **2413** and press **ENT** key

MEMon
MEMof

Activated or excluded memory.

This parameter allows to program the saving of the current counter value during the power off of the instrument.

MEM.on. = memorization of the count during the power OFF. When power ON the instrument, the display will visualize the last present value in the power OFF phase.

MEM.of. = excluded memorization of the count; every time that the instrument comes powered OFF and then powered ON the count comes lost and the instrument restart always from the initial condition.

RESon
RESof

RESET Key ON / OFF; this programming enables and disables the RESET function of frontal key RES during the operation of the counter. The disabling does not allow to reset the counter and the totalizer.

RES.on = RESET function of key RES **enabled**

RES.of. = RESET function of key RES **disabled**

d.p. 0
d.p. 4

Programming of the Decimal Point of the Counter and the Totalizer.

This programming allows to add a decimal point to the visualization on the 5 digits, in order to obtain counts with various resolutions.

d.p. = 0 Decimal Point excluded; visualization 99999

d.p. = 1 Decimal Point on the second display from right; visualization 9999,9

d.p. = 2 Decimal Point on the third party display from right; visualization 999,99

d.p. = 3 Decimal Point on the quarter display from right; visualization 99,999

d.p. = 4 Decimal Point on fifth display from right; visualization 9,9999

Attention, the Decimal Point is fictitious only, it doesn't realize any conversion.

Ou.1_
Ou.1_

Programming of the OUTPUT 1 RL1. This parameter allows to activate the RL1 relay to the beginning **_ I** or to the end **I_** of the count.

Ou.1 _ I = Activation of the RL1 relay to end of count

Ou.1 I_ = Activation of the RL1 relay to beginning of count

AP. P.
AP. r.

Activation mode of the programmed parameters.

With this programming is possible to activate the executed programmings directly to the exit of the programming or, when exited of the programming, after a RESET (with frontal key or from rear input)

A.P. = P. Activation of the parameters to the exit of the programming.

A.P. = r. Activation of the parameters to the exit of the programming after a RESET.

Pressing the key  the totalizer of impulses will be visualized for 5 sec.

tot.
99999

The totalizer visualizes all the impulses that the instrument counts from its input IN1. It can be resetted through frontal key RES only or from RESET input when it is visualized on the display.

OPERATION DIAGRAMS

OPERATION WITH MANUAL RESET AND INHIBIT

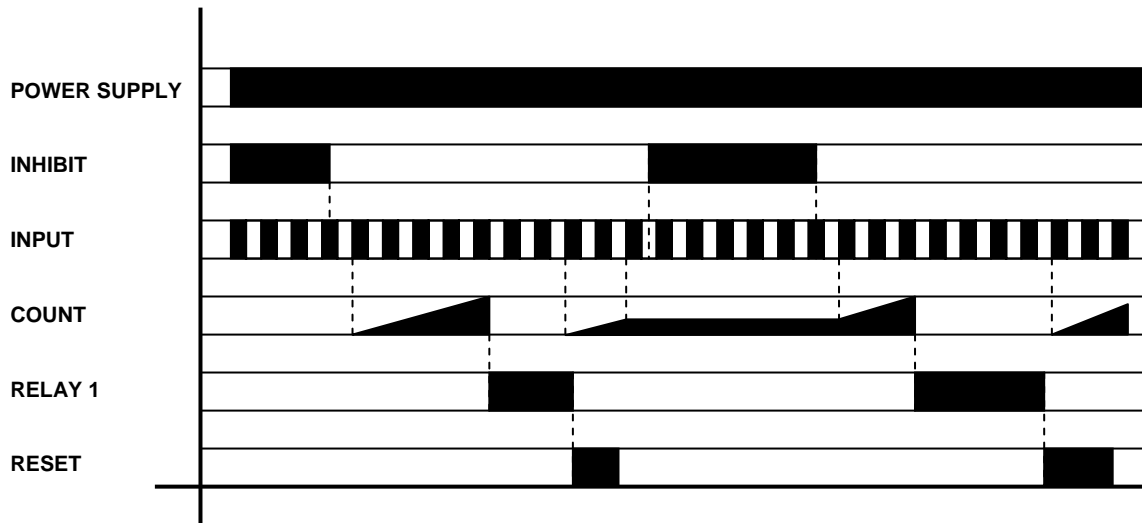

OPERATION WITH INHIBIT AND AUTOMATIC RESET

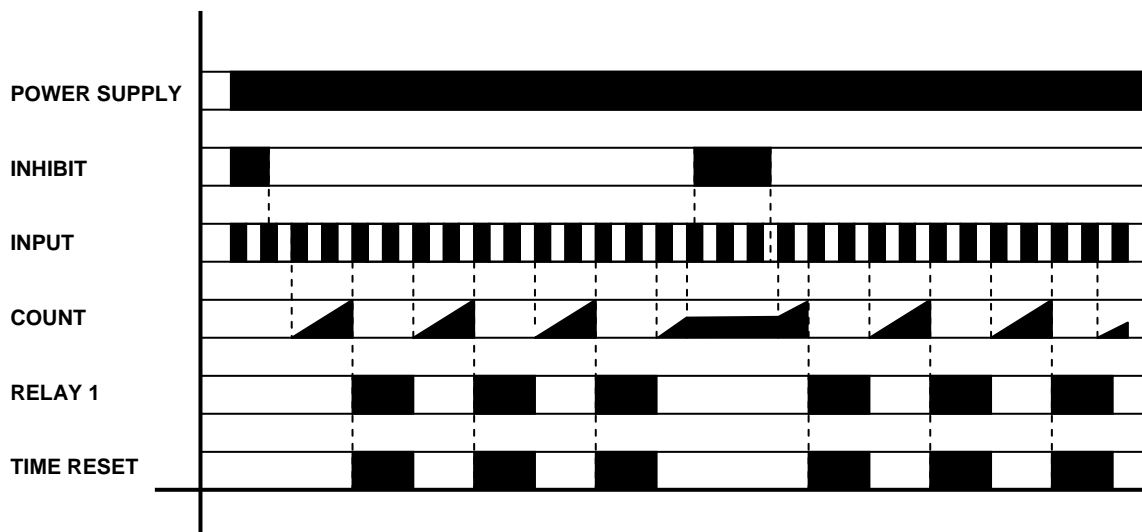

Z SERIES CONNECTIONS

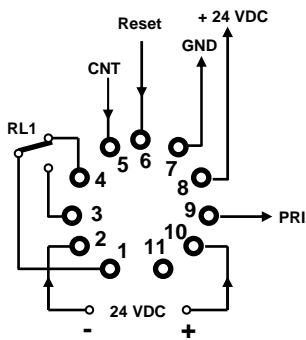
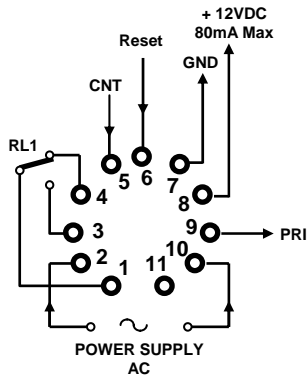

Z SERIES - INPUT SIGNALS

NPN

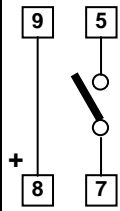

INPUT FOR NPN CONTACT

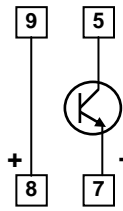

INPUT FOR NPN LOGIK

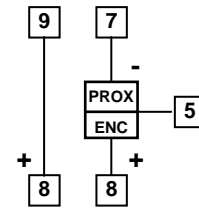

INPUT FOR PROXIMITI AND ENCODER AMPLIFIED 24 VDC



INPUT FOR NPN RESET

PNP

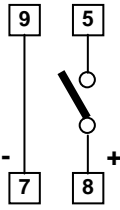

INPUT FOR PNP CONTACT

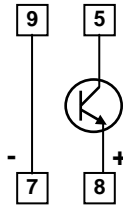

INPUT FOR PNP LOGIC

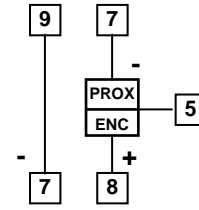

INPUT FOR PROXIMITI AND ENCODER AMPLIFIED 24 VDC



INPUT FOR NPN RESET

Z SERIES CONNECTIONS

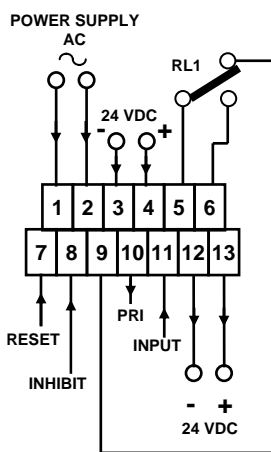

Z SERIES - INPUT SIGNALS

NPN

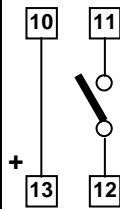

INPUT FOR NPN CONTACT

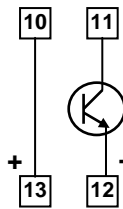

INPUT FOR NPN LOGIC

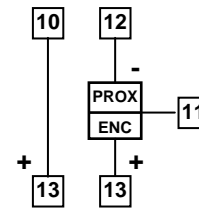

INPUT FOR PROXIMITI AND ENCODER AMPLIFIED 24 VDC

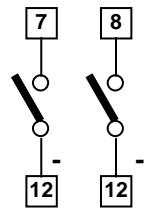

RESET INHIBIT NPN

PNP

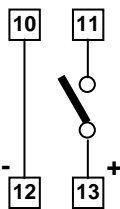

INPUT FOR PNP CONTACT

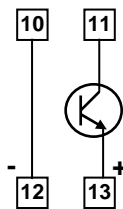

INPUT FOR PNP LOGIC

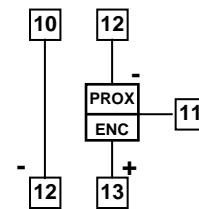

INPUT FOR PROXIMITI AND ENCODER AMPLIFIED 24 VDC

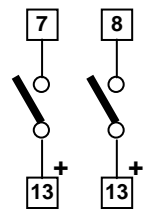

RESET INHIBIT NPN

OVERALL DIMENSIONS (mm)

FRONT

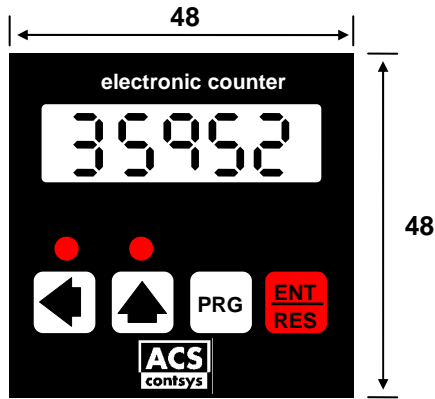

DRILL TEMPLATE

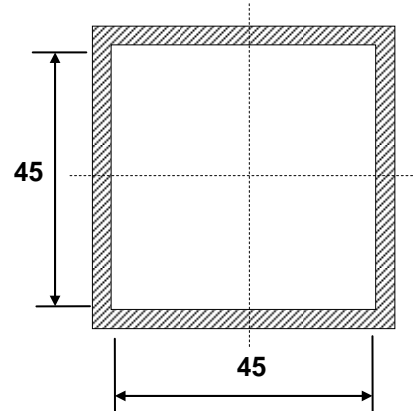

E SERIES SIDE

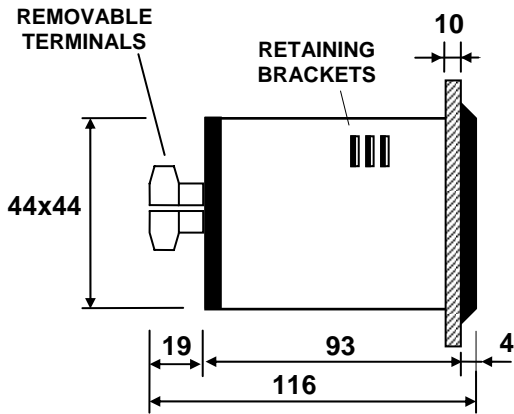

Z SERIES SIDE

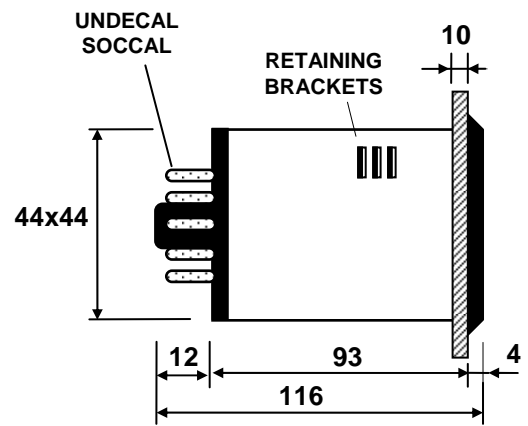

E SERIES REAR

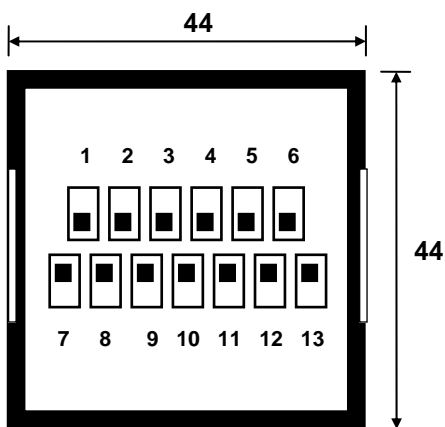

Z SERIES REAR

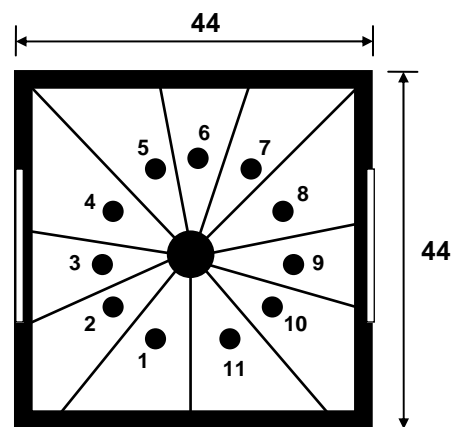

ACS-CONTROL-SYSTEM GmbH

Lauterbachstraße 57
 Tel : 08721 / 9668-0
<http://www.acs-controlsystem.de>
 e-mail: info@acs-controlsystem.de

84307 Eggenfelden
 Fax : 08721 / 9668-30