



VISUALIZED DIGITAL COUNTER WITH ONE SET POINT

Type:
NCM51

VISUALIZED DIGITAL 5 DIGITS COUNTER, WITH INPUT FOR SINGLE DIRECTIONAL COUNTS, ONE SET POINT OF INTERVENTION AND IMPULSES TOTALIZER.

The **NCM 51** counter finds application where there is the necessity to visualize and to control, through one programmable set point, mono-directional counts deriving from electromechanical and logical contacts, proximity and encoder.

Bauform 72 x 72 mm



MAIN FEATURES

- Frontal keyboard in polycarbonate (antiscratch, antioil, antacid).
- IP65 protection degree
- Accessible parameters with key software
- Removable terminals connection.
- Execution DIN 72 x 72.
- Recessed assembly.
- Special retaining brackets.

PROGRAMMABLE PARAMETERS

- One set points
- Reset time
- 2 conversion factors of the impulses
- Input (Slow / Fast)
- Count (Up / Down / Superior)
- Memory
- Reset key
- Decimal Point

TECHNICAL FEATURES

- | | |
|---|--|
| • POWER SUPPLY IN ALTERNATING CURRENT | : Single power 24 - 110 - 230 Vac (50 / 60 Hz). |
| • POWER SUPPLY IN CONTIUM CURRENT | : Single power 24 Vdc |
| • POWER SUPPLY TOLERANCE | : +10% - 15%. |
| • ABSORPTION | : 2 W - 3 VA. |
| • OPERATING TEMPERATURE | : -5 °C + 55 °C. |
| • CLIMATIC CONDITIONS | : U.R. 95 % at 40 °C (without condensate). |
| • COUNTER AND TOTALIZER VISUALIZATION | : 5 digits, 11 mm high |
| • MULTIPLICATION FACTOR M1 OF THE IMPULSES IN INPUT | : Programmable from 0,00001 to 9,99999. |
| • MULTIPLICATION FACTOR M2 OF THE IMPULSES IN INPUT | : Programmable from 1 to 99. |
| • INPUT TYPE | : Suitable for electromechanical contact and NPN or PNP signals |
| • COUNT FREQUENCY FOR LOGICAL SIGNALS | : Up to 15 KHz with Duty Cycle=50%. |
| • MINIMUM TIME FOR COUNT IMPULSES | : 0,25 mSec. |
| • CUT FREQUENCY FOR ELECTROMECHANICAL INPUTS | : About 30 Hz. |
| • AUXILIARY INPUTS POWER SUPPLY | : 24 Vdc – 80 mA available on terminals. |
| • COMMAND IMPUTS | : 1 Counter Reset - 1 Inhibit. |
| • OUTPUTS | : 1 relay with operating contacts - capacity 2A - 250Vac. |
| • RELAY RESET | : Manual or automatic with excitation time from 0,1 to 99,9 sec. |
| • PROGRAMMED DATA MEMORY | : static (no battery) |

DESCRIPTION OF THE FRONTAL KEYBOARD

 **WHITE**

The key '**LEFT ARROW**' in normal operating phase visualizes, blinking, all the programmings executed without the limitation of the insertion code. The time of scansion of the programmings is given from the pressure of the same key. It exits automatically from this phase after 5 sec of the last pressure of the same key.
In programming phase it moves the cursor of the figure towards left of a step, than at the beginning it is on the right side first one on the. At the end it resumes from the first one to right.

 **WHITE**

The key '**UP ARROW**' in normal operating phase visualizes the totalizer of impulses.
In programming phase it increases the value of the blinking figure.

 **WHITE**

The key '**PRG**' pressed for 2 sec. allows to enter in the programming phase, visualizing on display C.0000.
In the programming phase, pressing key 'PRG' impulsively, it exits from the programming phase. The instrument exits automatically from the programming phase, 60 sec. after the pressure of the last key.

 **RED**

The key '**ENT/RES**' in normal phase of counting has the 'RESET' function, with the modalities to it attributed in the programming phase.
In programming phase it confirms and memorizes the visualized data and passes to the successive function. If it has arrived to list end it resumes from the beginning.

INPUTS / OUTPUTS DESCRIPTION

AC POWER SUPPLY
(inputs 5-6)

AC Power Supply Input of the instrument; it can be to 24 - 110 - 230 VAC in according to demand.

DC POWER SUPPLY
(inputs 7-8)

DC Power Supply Input of the instrument; input 8 (-), input 7 (+).

24 VDC - 80mA
(inputs 9-10)

24 VDC - 80 mA auxiliary Power Supply that the instrument supply to feed the Encoder and proximity amplified.

INPUT
(input 11)

Input of count adapted for electromechanical and logical contacts, encoder and 3 wires proximity amplified, configurable in Positive (PNP) and Negative (NPN) logic.

RESET
(input 12)

Input of RESET that executes the reset of the visualized count showed on display at the moment of its activation.

INHIBIT
(input 13)

Input of count inhibition: when activated it blocks the count of the normal counter and the totalizer.

RL1
(inputs 1 - 2 - 3)

Output of Relay 1, connected to the operation of the Set Point S1. The Common, Normally Open and Normally Close contacts are available.

DESCRIPTION OF THE LED'S OPERATION

LED 1

It comes activated to the reaching of the Set Points S1.

SET POINTS PROGRAMMING

For SET POINTS programming access, proceed as follow:

- Press key 'PRG' in impulsive mode; on display appears:

| |
|-------|
| S 1 |
| 99999 |

S.1 = SET POINT 1, main Set Point, programmable between 0 and 99999. If programmed = 0 the Set Point is excluded and the instrument works like a totalizer and predisposes the count in UP mode.

Key **ENT** confirms the data. In order to exit the programming, press key **PRG**.

PROGRAMMING OF THE OPERATION PARAMETERS

The programmable parameters are divided in two groups and protect with a 4 figures code.

In order to approach the programming, proceed in the following way:

- Press key **PRG** for about 2 sec. On the display appears:

| |
|------|
| Cod |
| 0000 |

GROUP 1 : in order to approach the parameters of group 1, insert code **2357** and press **ENT**

| |
|-------|
| n 1 |
| 10000 |

5 digits multiplier, programmable from 0,1 to 9,9999. This parameter allows to convert the number of the input impulses, showing them on the display in an other format. If it programmed = 0 it comes reprogrammed automatically to 1. If a value lower than 1 is inserted, it obtains the division of the impulses. Es. I want to divide by 25 the impulses in input; calculation 1 : 25 = 0.04.

Attention: the variation of the value of the multiplying modifies automatically the value of the count and the totalizer.

| |
|-------|
| n2 10 |
|-------|

2 digits multiplier, programmable from 1 to 99. This parameter allows to convert the number of the input impulses, showing them on the display in other format. If it programmed = 0 it comes reprogrammed automatically to 1.

Attention: the variation of the value of the multiplying modifies automatically the value of the count and the totalizer.

| |
|-----------|
| t.r. 99.9 |
|-----------|

t.r. = Time of Automatic Reset, programmable from 0.0 to 99.9 sec. This parameter allows to make to work the instrument in **automatic** mode. When the count arrives to the value of S.1, it automatically resets the count, excites the RL1 relay and it resumes to count without to lose the impulses. The RL1 relay remains excited for the set up time in **t.r.** If the time of reset is programmed = 0 (0.0) the instrument gets ready to works in **manual** mode.

Particular cases: if the set up time **t.r.** is bigger than the time employed to the count to arrive to the values of S.1, the relay will never come unactivated.

| |
|------|
| In F |
| In S |

Input Fast - Slow.

This programming allows to predispose the input of count to read signals coming from electromechanical contacts (relays, switches etc.) that introduces false signals, or from logical signals like proximity, encoder, transistor etc.)

In = F. predisposes the instrument in order to read logical signals up to 15 KHz.

In = S. predisposes the instrument in order to read electromechanical contacts up to 30 Hz.

| |
|-------|
| Cn UP |
| Cn dn |
| Cn Sp |

Count UP / DOWN / Superior.

Count = Up: the counter gets ready to visualize the count in increasing way (UP), starting from zero up to the programmed value of set point. To ended count it behave in Manual or Automatic mode like programmed in **t.r.**

Count = dn: the counter gets ready to visualize the count in decreasing way (DOWN), starting from the programmed value of set point to zero. To ended count it behave in Manual or Automatic mode like programmed in **t.r.**

Count = Sp: the counter gets ready to visualize the count in increasing way, starting from zero up to the programmed value of set point. To the attainment of the value of programmed set point it behave as in the Manual count and continues to count the impulses in input.

PROGRAMMING OF THE OPERATION PARAMETERS

The programmable parameters are divided in two groups and protect with a 4 figures code.

In order to approach the programming, proceed in the following way:

- Press key **PRG** for about 2 sec. On the display appears:

| |
|------|
| Cod |
| 0000 |

GROUP 2 : in order to approach the parameters of **group 1**, insert code **2413** and press **ENT** key

| |
|-------|
| MEMon |
| MEMof |

MEM. = Activated or excluded memory.

This parameter allows to program the saving of the current counter value during the power off of the instrument.

MEM.on. = memorization of the count during the power OFF. When power ON the instrument, the display will visualize the last present value in the power OFF phase.

MEM.of. = excluded memorization of the count; every time that the instrument comes powered OFF and then powered ON the count comes lost and the instrument restart always from the initial condition.

| |
|-------|
| RESon |
| RESof |

RES. = RESET Key ON / OFF; this programming enables and disables the RESET function of frontal key RES during the operation of the counter. The disabling does not allow to reset the counter and the totalizer.

RES.on = RESET function of key RES **enabled**

RES.of. = RESET function of key RES **disabled**

| |
|--------|
| d.p. 0 |
| d.p. 4 |

d.P. = Programming of the Decimal Point of the Counter and the Totalizer.

This programming allows to add a decimal point to the visualization on the 5 digits, in order to obtain counts with various resolutions.

d.p. = 0 Decimal Point excluded; visualization 99999

d.p. = 1 Decimal Point on the second display from right; visualization 9999,9

d.p. = 2 Decimal Point on the third party display from right; visualization 999,99

d.p. = 3 Decimal Point on the fourth display from right; visualization 99,999

d.p. = 4 Decimal Point on fifth display from right; visualization 9,9999

Attention, the Decimal Point is fictitious only, it doesn't realize any conversion.

| |
|---------|
| Ou.1 I- |
| Ou.1 I_ |

Ou. = Programming of the OUTPUT 1 RL1. This parameter allows to activate the RL1 relay to the beginning I_ or to the end I- of the count.

Ou.1 I- = Activation of the RL1 relay to end of count

Ou.1 I_ = Activation of the RL1 relay to beginning of count

| |
|---------|
| A.P. P. |
| A.P. r. |

A.P. = Activation mode of the programmed parameters.

With this programming is possible to activate the executed programmings directly to the exit of the programming or, when exited of the programming, after a RESET (with frontal key or from rear input)

A.P. = P. Activation of the parameters to the exit of the programming.

A.P. = r. Activation of the parameters to the exit of the programming after a RESET.

Pressing the key  the totalizer of impulses will be visualized for 5 sec.

| |
|-------|
| tot. |
| 99999 |

The totalizer visualizes all the impulses that the instrument counts from its input IN1. It can be resetted through frontal key RES only or from RESET input when it is visualized on the display.

OPERATION DIAGRAMS

OPERATION WITH MANUAL RESET AND INHIBIT

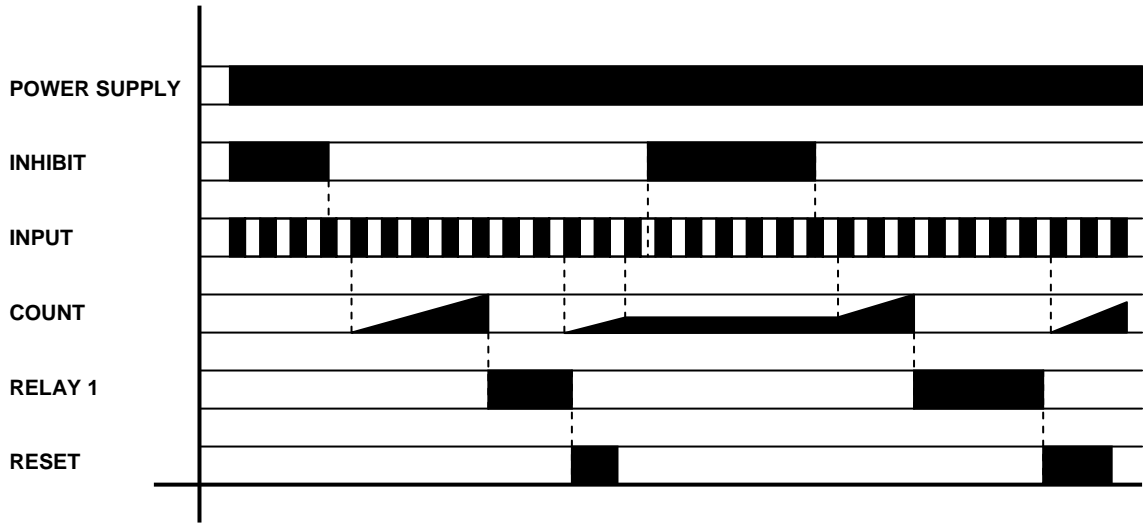

OPERATION WITH INHIBIT AND AUTOMATIC RESET

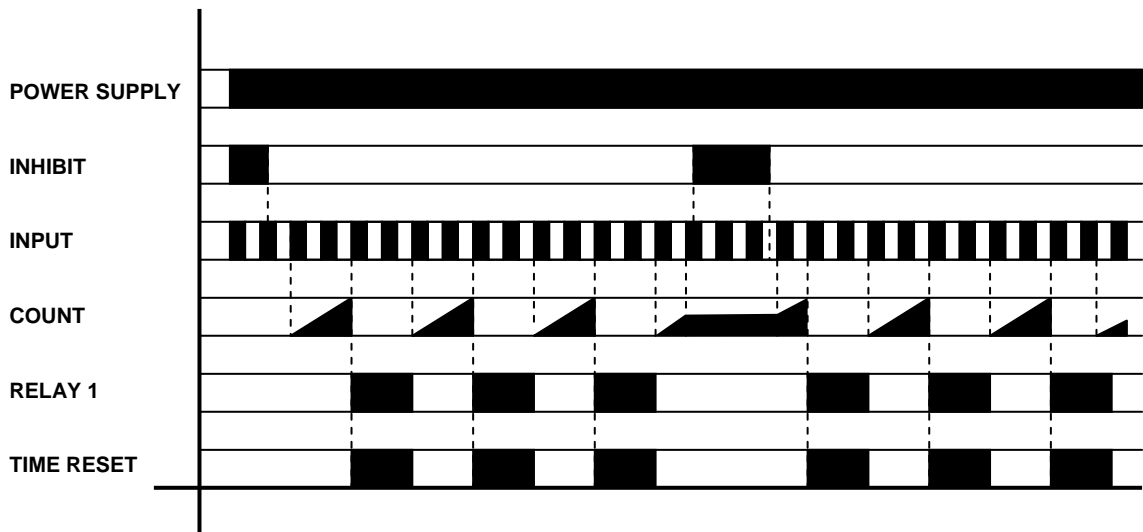

CONNECTIONS

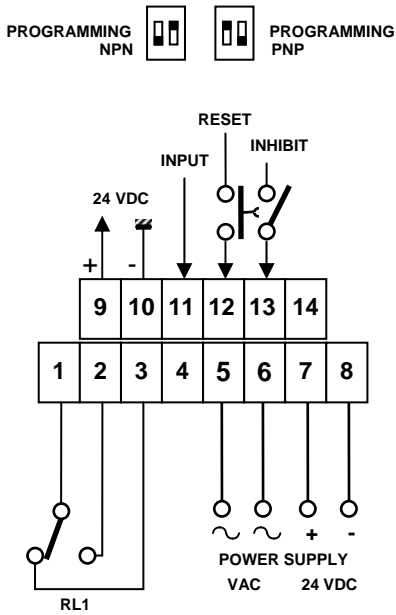

INPUT SIGNALS

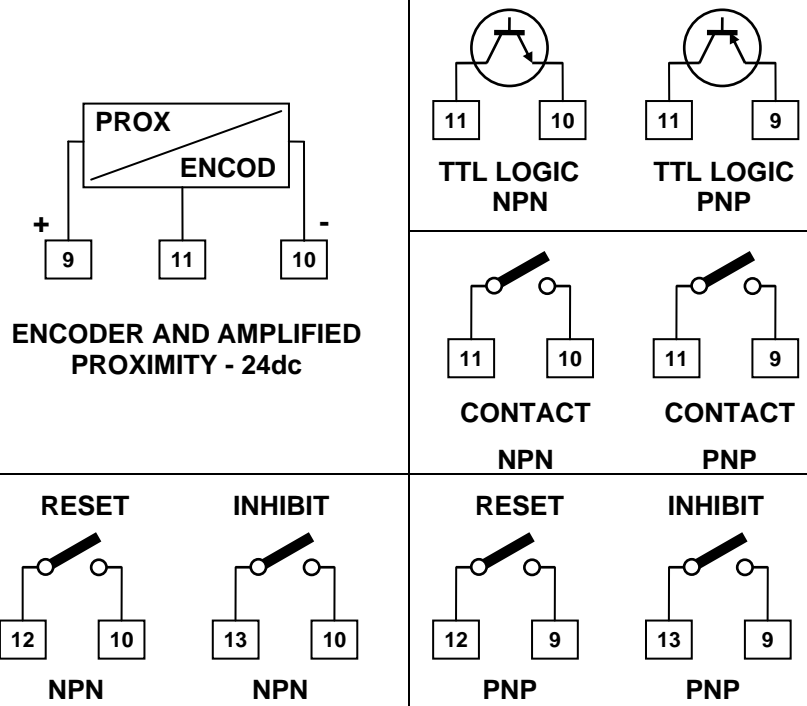

DIMENSIONS

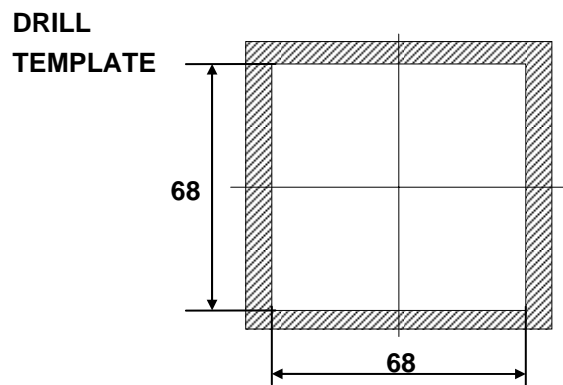
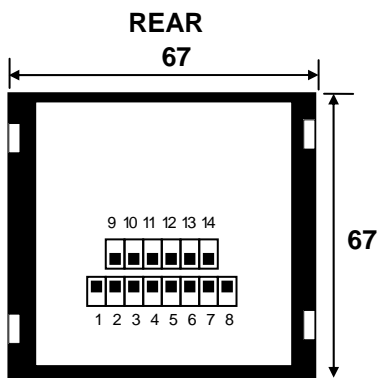
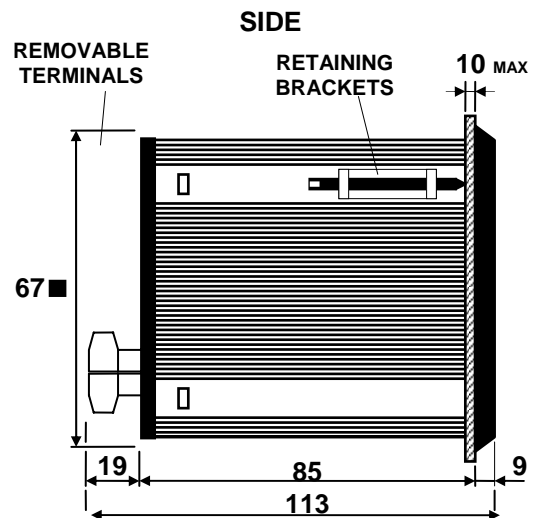
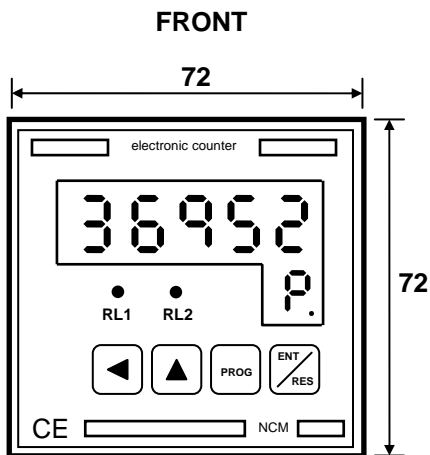

ACS Control System GmbH
 Lauterbachstr. 57 1/2
 84307 Eggenfelden
 Tel : 08721/ 9668-0
 Fax : 08721/ 9668-30
<http://www.acs-controlsystem.de>
 e-mail: info@acs-controlsystem.de

Agent: