



®

VISUALIZED DIGITAL PERIOD COUNTER WITH ONE SET POINT

Type:

NFM41

PROGRAMMABLE DIGITAL VISUALIZATOR OF ROTATIONS WITH 4 DIGITS, WITH ONE SET POINT AND INPUT SUITABLE FOR MONO DIRCTIONAL COUNTING.

The period counter model **NFM41** is used to display and control, through a relay threshold, rotational or linear speeds or counting referred to a pre selected time base. All the common types of controls are available using five different programmable operations.

It reads signals coming form electromechanical and logical contacts, proximity switches and encoder. It finds application like RPM meter, tachometer, speed meter, productions meter etc.



GENERAL FEATURES

- Frontal keyboard in polycarbonate (antiscratch, antioil, antacid).
- IP65 protection degree
- Accessible parameters with key software
- Removable terminals connection.
- Execution DIN 72 x 72
- Recessed assembly.
- Special retaining brackets.

PROGRAMMABLE PARAMETERS

- One Set Point
- Multiplier Factor
- Divisor Factor
- Time Base
- Display Reset Time
- Display Adjournalment Time
- Input for Electromechanical or Logic Contacts
- Programmable Reset Key
- Programmable Decimal Point
- Operating Mode
- Input Inhibit Time

TECHNICAL FEATURES

- | | |
|--|---|
| • POWER SUPPLY IN ALTERNATE CURRENT | : Single power 24 - 110 - 230 Vac (50 / 60 Hz). |
| • POWER SUPPLY IN DIRECT CURRENT | : 24 Vdc |
| • POWER SUPPLY TOLERANCE | : +10% - 15%. |
| • ABSORPTION | : 2 W - 3 VA. |
| • OPERATING TEMPERATURE | : -5 °C + 55 °C. |
| • CLIMATIC CONDITIONS | : U.R. 95 % a 40 °C (without condensate). |
| • COUNTER AND TOTALIZER VISUALIZATION | : 4 digits, display high 11mm. |
| • MULTIPLICATION FACTOR OF THE INPULSES IN INPUT | : Programmable from 1 to 10000. |
| • DIVISOR FACTOR OF THE INPULSES IN INPUT | : Programmable from 1 to 10000. |
| • TIME BASE | : Programmable between 1 / 60 / 3600. |
| • INPUT TYPE | : suitable for electromechanical contacts, amplified proximity and encoder, NPN and PNP |
| • MAXIMUM COUNT FREQUENCY | : up to 25 KHz with Duty Cycle=50%. |
| • MINIMUM TIME FOR INPULSES COUNT | : 0,25 mSec. |
| • CUT OFF FREQUENCY FOR ELECTROMECHANICAL INPUTS | : about 30 Hz. |
| • COMMAND INPUTS | : 1 Counter Reset - 1 Count Inhibit. |
| • OUTPUT | : 1 relay with operating contacts - capacity 2A - 250Vac. |
| • RESET RELAY | : Manual or automatic with excitation time from 0,1 to 99,9 sec. |
| • AUXILIARY INPUT SUPPLY | : 24 Vdc - 80 mA available on terminals. |
| • PROGRAMMED DATA MEMORY | : Static (no battery) |

DESCRIPTION OF THE FRONTAL KEYBOARD

 **YELLOW**

The key '**LEFT ARROW**' in normal operating phase visualizes, blinking, all the programmings executed without the limitation of the insertion code. The time of scansion of the programmings is given from the pressure of the same key. It exits automatically from this phase after 5 sec of the last pressure of the same key.

In programming phase it moves the cursor of the figure towards left of a step, than at the beginning it is on the right side first one on the. At the end it resumes from the first one to right.

 **YELLOW**

The key '**UP ARROW**' in normal operating phase visualizes the totalizer of impulses.

In programming phase it increases the value of the blinking figure.

 **BLUE**

The key '**PRG**' pressed for 2 sec. allows to enter in the programming phase, visualizing on display C.0000.

In the programming phase, pressing key 'PRG' impulsively, it exits from the programming phase. The instrument exits automatically from the programming phase, 60 sec. after the pressure of the last key.

 **RED**

The key '**ENT/RES**' in normal phase of counting has the 'RESET' function, with the modalities to it attributed in the programming phase.

In programming phase it confirms and memorizes the visualized data and passes to the successive function. If it has arrived to list end it resumes from the beginning.

INPUTS / OUTPUTS DESCRIPTION

AC POWER SUPPLY
(inputs 5-6)

AC Power Supply Input of the instrument; it can be to 24 - 110 - 230 VAC in according to demand.

DC POWER SUPPLY
(inputs 7-8)

DC Power Supply Input of the instrument; input 8 (-), input 7 (+).

24 VDC - 80mA
(inputs 9-10)

24 VDC - 80 mA auxiliary Power Supply that the instrument supply to feed the Encoder and proximity amplified.

INPUT
(input 11)

Input of count adapted for electromechanical and logical contacts, encoder and 3 wires proximity amplified, configurable in Positive (PNP) and Negative (NPN) logic.

RESET
(input 12)

Input of RESET that executes the reset of the visualized count showed on display at the moment of its activation.

INHIBIT
(input 13)

Input of count inhibition: when activated it blocks the count of the normal counter and the totalizer.

RL1
(inputs 1 - 2 - 3)

Output of Relay 1, connected to the operation of the Set Point S1. The Common, Normally Open and Normally Close contacts are available.

DESCRIPTION OF THE LED'S OPERATION

LED 1

It comes activated to the reaching of the Set Points S1.

LED 1 (REAR)

It signals the presence of the input signal.

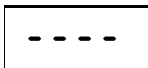

When the device is switched on and when there are no impulses in its input, the device visualize 4 horizontal bars.

Pressing the key  the totalizer of impulses will be visualized for 5 sec.

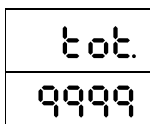

The totalizer visualizes all the impulses that the instrument counts from its input IN1. It can be resetted through frontal key RES only or from RESET input when it is visualized on the display.

SET POINTS PROGRAMMATION

For SET POINT and HYSTERESIS programming access, proceed as follow:

- Press key '**PRG**' in impulsive mode; on display appears:

SG.1
1000

SG.1 = SET POINT 1, programmable between 0 and 9999.

HSt.
100

HSt. = Hysteresis, programmable between 0 and 9999. It's active in the programming **Mode 2** and 3 only.

Key **ENT** confirms the data. In order to exit the programming, press key **PRG**.

PROGRAMMING OF THE OPERATION PARAMETERS

The programmable parameters are divided in two groups and protect with a 4 figures code.

In order to approach the programming, proceed in the following way:

- Press key **PRG** for about 2 sec. On the display appears:

Cod
000

GROUP 1 : in order to approach the parameters of group 1, insert code **101** and press **ENT**

F.M
0001

F.M. = 4 digits multiplier, programmable from 1 to 10000. This parameter allows to multiply the number of the input impulses, showing them on the display in an other format. If it programmed = 0 it means programmed 10000.

Attention: the variation of the value of the multiplying modifies automatically the value of the count and the totalizer.

F.d
0001

F.d. = 4 digits divisor, programmable from 1 to 10000. This parameter allows to divide the number of the input impulses, showing them on the display in an other format. If it programmed = 0 it means programmed 10000.

Attention: the variation of the value of the multiplying modifies automatically the value of the count and the totalizer.

b.t.
60

b.t. = Time Base.

This programming allows to select in which time base shows on the display the measure in input. There are three scales:

1 = Time Base: seconds, measure visualization in seconds (ex. Meters/seconds)

60 = Time Base: minutes, measure visualization in minutes (ex. Liters/minutes)

3600 = Time Base: hours, measure visualization in hours (ex. Bottles/hour)

PROGRAMMING OF THE OPERATION PARAMETERS

The programmable parameters are divided in two groups and protect with a 4 figures code.

In order to approach the programming, proceed in the following way:

- Press key **PRG** for about 2 sec. On the display appears:

Cod
000

GROUP 2 : in order to approach the parameters of **GROUP 2**, insert code **020** and press **ENT**

E. 01

E.i = Delay Time for the excitation of the Relay output1.
This parameter allows to program the delay time of the activation of the Relay output RL1. It's programmable between 0 (no delay) and 9,9 sec.

d. 01

d.i = Delay Time for the unexcitation of the Relay output1.
This parameter allows to program the delay time of the unactivation of the Relay output RL1. It's programmable between 0 (no delay) and 9,9 sec.

t.r. 10

t.r. = Reset time of the display.
This parameter allows to program the maximum time from the last impulse after that the instrument reset the display, showing the four horizontal bars. If programmed = 0, with no impulses in input the instrument shows the last calculated value. If the programmed time is lower than the time between the impulses, the instrument shows the four horizontal bars.
This parameter is useful to indicate when a plant is in stop or when there are no impulses in input or when the impulse source is damaged. It's programmable between 1 (instantaneous) and 99 seconds.

t.d 01

t.d. = Updating time of the display.
This parameter allows to program the delay time of the data adjournment on the display. It's programmable between 0 (instantaneous) and 9,9 sec

In F
In S

Input Fast - Slow.
This programming allows to set the count input to read signals coming from electromechanical contacts (relays, switches etc.) or from logical signals like proximity switches transistor and encoder.
In = F. sets the input to read digital signals up to 28 KHz.
In = S. sets the input to read electromechanical signals up to 25 Hz.

rSou
rSon

Operation of the RESET Key; this programming enable and disable the RESET working of the frontal RES key during the operation, as in the following modes:
RS.ou. = executes the RESET of the visualized parameter + the Relay Output
RS.on. = executes the RESET of the visualized parameter
RS.oF. = RESET working of the RES key excluded.
RS.F.t. = executes, at the same time, the RESET of the frequencymeter, of the totalizer and of the Relay Outputs

dP. 0
dP. 4

d.P. = Programming of the Decimal Point
This programming allows to add a decimal point to the visualization on the 4 digits, in order to obtain counts with various resolutions.
d.p. = 0 Decimal Point excluded; visualization 9999
d.p. = 1 Decimal Point on the second display from right; visualization 999,9
d.p. = 2 Decimal Point on the third party display from right; visualization 99,99
d.p. = 3 Decimal Point on the fourth display from right; visualization 9,999
d.p. = 4 Floating Point.

I. 001

I = Initial Time of inhibition of the activation of the Relay output.
This parameter allows to inhibit the activation of the relay output for the time sets. During this time the relay output is excluded. It's operation follows the programming in **Ut.** under the code **121**. It's programmable between 0 (excluded) and 999 sec.

AP. P.
AP. r.

A.P. = Activation mode of the programmed parameters.
With this programming is possible to activate the executed programmings directly to the exit of the programming or, when exited of the programming, after a RESET (with frontal key or from rear input).
A.P. = P. Activation of the parameters to the exit of the programming.
A.P. = r. Activation of the parameters to the exit of the programming after a RESET.

PROGRAMMING OF THE OPERATION PARAMETERS

The programmable parameters are divided in two groups and protect with a 4 figures code.

In order to approach the programming, proceed in the following way:

- Press key **PRG** for about 2 sec. On the display appears:

Cod
000

nd 0

ut. 0

GROUP 3 : in order to approach the parameters of GROUP 3, insert code **121** and press **ENT**

Md. = Programming of the operation Mode

This programming allows to program the operation mode of the Set Points, of the Hysteresis and of the Relay Outputs.

Md. = 0 Lower Set Point (RL1 excited under the Set Point value)

Md. = 1 Upper Set Point (RL1 excited over the Set Point value)

Md. = 2 Upper Set Point + Hysteresis (RL1 excited Over the Set Point value and un-excited under the Hysteresis value)

Md. = 3 Lower Set Point + Hysteresis (RL1 excited under the Set Point value and un-excited over the Set Point value + Hysteresis)

Md. = 4 Lower Set Point + maintained relay (RL1 even Over the Set Point value; it can be resets after a RESET command or switching OFF and ON the instrument).

Md. = 5 Upper Set Point + maintained relay (RL1 excited even Under the Set Point value; it can be resets after a RESET command or switching OFF and ON the instrument).

Ut. = Programming of the RESET Input and of the operation of the INHIBIT time.

This programming allows to select the operation of the RESET input and the operation mode of the Inhibit time.

Ut. = 0 Reset of the visualized value + relay (with inhibit time at the starting)

Ut. = 1 Frequency Reset only + relay (with inhibit time at the starting)

Ut. = 2 Frequency Reset + totalizer (at the same time) + relay (with inhibit time at the starting)

Ut. = 3 Reset of the visualized value + relay (with inhibit time with the first impulse)

Ut. = 4 Frequency Reset only + relay (with inhibit time with the first impulse).

Ut. = 5 Frequency Reset + totalizer (at the same time) + relay (with inhibit time with the first impulse).

DECLARATION OF 'CE' CONFORMITY

CE NORMATIVE CONFORMITY

Borgolavezzaro, October, 03rd 2005

The building firm: **CET s.r.l.**

Head office: **Strada Statale 211, Km 53,3**
28071 Borgolavezzaro (No) ITALIA
Tel. 0039 - 321 - 885301 Fax. 0039 - 321 - 885560

declare that the products:

type : **Visualized Digital Period Counter**

model: **NFM41**

use class: **Industrial**

are in conformity with the following normatives:

EN55011
ENV50141
ENV50204
EN61000-4-2
EN61000-4-4

The constructor : **CET s.r.l.**

Signature

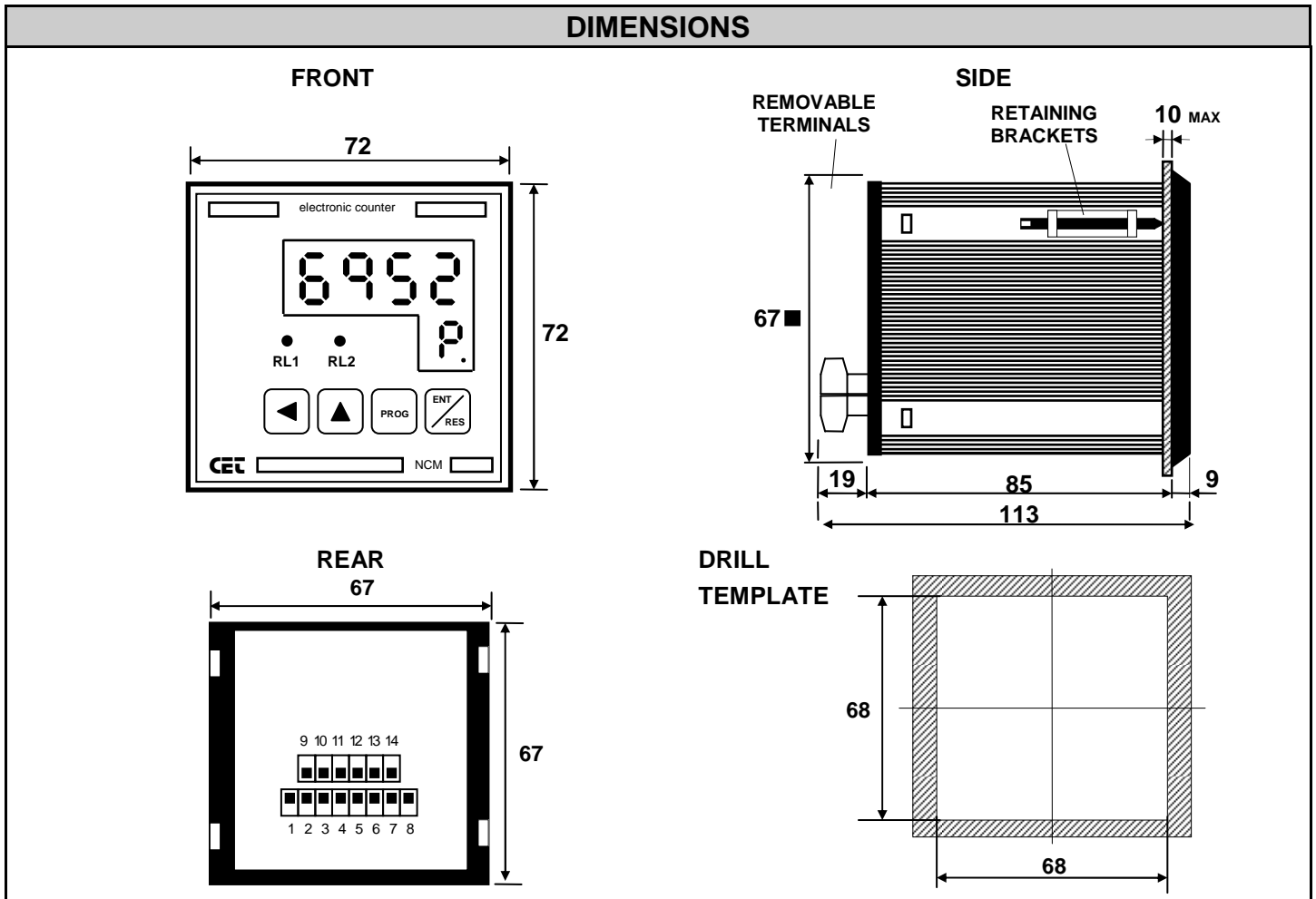
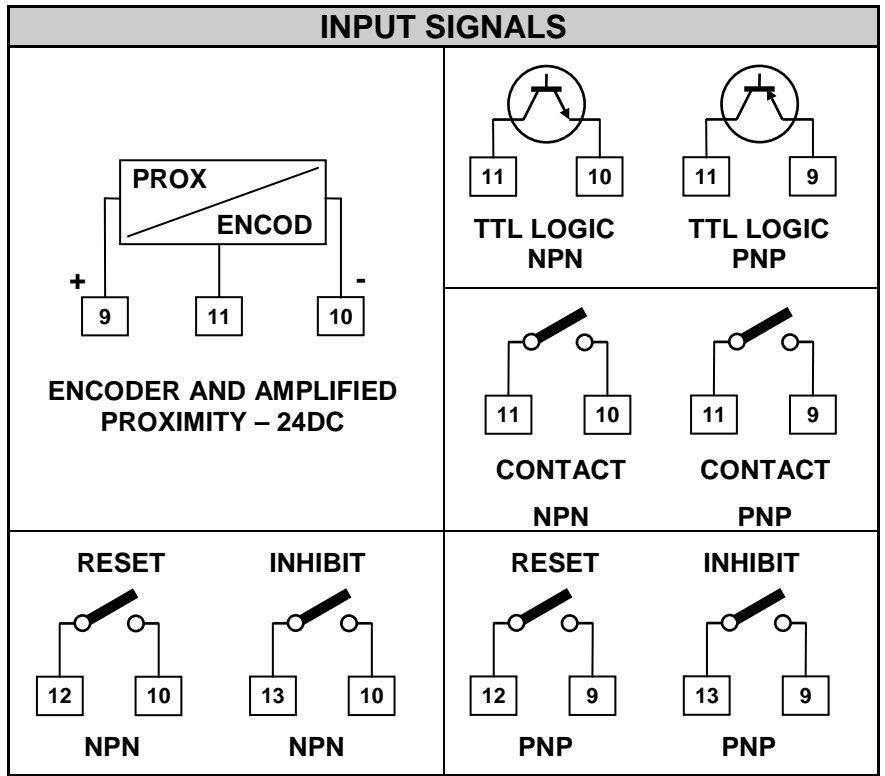
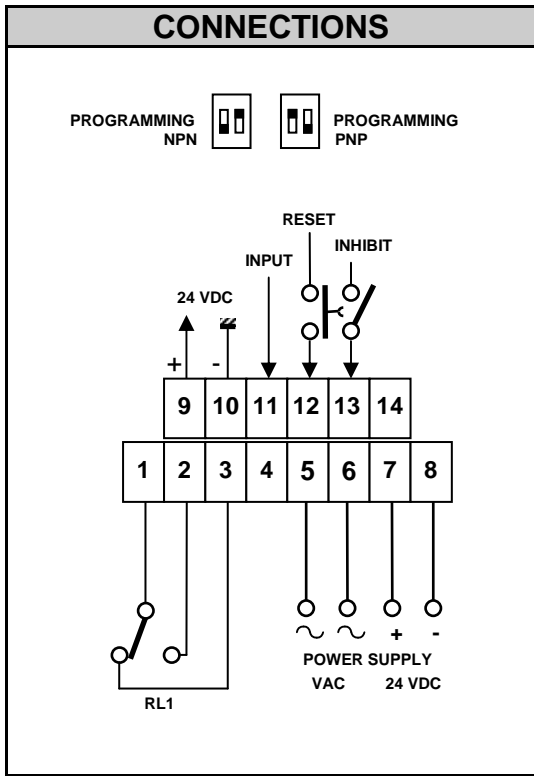

ACS-Control-System GmbH
Lauterbachstr. 57
D- 84307 Eggenfelden

Tel: +49 (0) 8721-9668-0
Fax: +49 (0) 8721-9668-30

ACS-CONTROL-SYSTEM
knowledge and systems

Your partner for measuring technology and automation



Vers. 1.0

NFM 41

Pag. 8

info@acs-controlsystem.de
www.acs-controlsystem.de