



# VISUALIZED DIGITAL PERIOD COUNTER WITH TWO SET POINTS

Type:  
**NFM42E0**

PROGRAMMABLE DIGITAL VISUALIZATOR OF ROTATIONS WITH 4 DIGITS, WITH TWO SET POINTS AND INPUT SUITABLE FOR MONO DIRCTIONAL COUNTING.

The period counter model **NFM42** is used to display and control, through a relay threshold, rotational or linear speeds or counting referred to a pre selected time base. All the common types of controls are available using five different programmable operations.

It reads signals coming form electromechanical and logical contacts, proximity switches and encoder.

It finds application like RPM meter, tachometer, speed meter, productions meter etc.



## GENERAL FEATURES

- Frontal keyboard in polycarbonate (antiscratch, antioil, antacid).
- IP65 protection degree
- Accessible parameters with key software
- Removable terminals connection.
- Execution DIN 72 x 72
- Recessed assembly.
- Special retaining brackets.

## PROGRAMMABLE PARAMETERS

- Two Set Points
- Multiplier Factor
- Divisor Factor
- Time Base
- Display Reset Time
- Display Adjournment Time
- Input for Electromechanical or Logic Contacts
- Programmable Reset Key
- Programmable Decimal Point
- Operating Mode
- Input Inhibit Time

## TECHNICAL FEATURES

|  |   |
|--|---|
| • POWER SUPPLY IN ALTERNATE CURRENT              | : Single power 24 - 110 - 230 Vac (50 / 60 Hz).   |
| • POWER SUPPLY IN DIRECT CURRENT                 | : 24 Vdc  |
| • POWER SUPPLY TOLERANCE                         | : +10% - 15%.   |
| • ABSORPTION                                     | : 2 W - 3 VA.   |
| • OPERATING TEMPERATURE                          | : -5 °C + 55 °C.  |
| • CLIMATIC CONDITIONS                            | : U.R. 95 % a 40 °C (without condensate).   |
| • COUNTER AND TOTALIZER VISUALIZATION            | : 4 digits, display high 11mm.  |
| • MULTIPLICATION FACTOR OF THE IMPULSES IN INPUT | : Programmable from 1 to 10000.   |
| • DIVISOR FACTOR OF THE IMPULSES IN INPUT        | : Programmable from 1 to 10000.   |
| • TIME BASE                                      | : Programmable between 1 / 60 / 3600.   |
| • INPUT TYPE                                     | : suitable for electromechanical contacts, amplified proximity and encoder, NPN and PNP |
| • MAXIMUM COUNT FREQUENCY                        | : up to 25 KHz with Duty Cycle=50%.   |
| • MINIMUM TIME FOR IMPULSES COUNT                | : 0,25 mSec.  |
| • CUT OFF FREQUENCY FOR ELECTROMECHANICAL INPUTS | : about 30 Hz.  |
| • COMMAND INPUTS                                 | : 1 Counter Reset - 1 Count Inhibit.  |
| • OUTPUTS  | : 2 relays with operating contacts - capacity 2A - 250Vac.                              |
| • RESET RELAY                                    | : Manual or automatic with excitation time from 0,1 to 99,9 sec.                        |
| • AUXILIARY INPUT SUPPLY                         | : 24 Vdc - 80 mA available on terminals.  |
| • PROGRAMMED DATA MEMORY                         | : Static (no battery)   |

## DESCRIPTION OF THE FRONTAL KEYBOARD

### **YELLOW**

The key '**LEFT ARROW**' in normal operating phase visualizes, blinking, all the programmings executed without the limitation of the insertion code. The time of scansion of the programmings is given from the pressure of the same key. It exits automatically from this phase after 5 sec of the last pressure of the same key.

In programming phase it moves the cursor of the figure towards left of a step, than at the beginning it is on the right side first one on the. At the end it resumes from the first one to right.

### **YELLOW**

The key '**UP ARROW**' in normal operating phase visualizes the totalizer of impulses.

In programming phase it increases the value of the blinking figure.

### **BLUE**

The key '**PRG**' pressed for 2 sec. allows to enter in the programming phase, visualizing on display C.0000.

In the programming phase, pressing key 'PRG' impulsively, it exits from the programming phase. The instrument exits automatically from the programming phase, 60 sec. after the pressure of the last key.

### **RED**

The key '**ENT/RES**' in normal phase of counting has the 'RESET' function, with the modalities to it attributed in the programming phase.

In programming phase it confirms and memorizes the visualized data and passes to the successive function. If it has arrived to list end it resumes from the beginning.

## INPUTS / OUTPUTS DESCRIPTION

### **AC POWER SUPPLY** (inputs 5-6)

AC Power Supply Input of the instrument; it can be to 24 - 110 - 230 VAC in according to demand.

### **DC POWER SUPPLY** (inputs 7-8)

DC Power Supply Input of the instrument; input 8 (-), input 7 (+).

### **24 VDC - 80mA** (inputs 9-10)

24 VDC - 80 mA auxiliary Power Supply that the instrument supply to feed the Encoder and proximity amplified.

### **INPUT** (input 11)

Input of count adapted for electromechanical and logical contacts, encoder and 3 wires proximity amplified, configurable in Positive (PNP) and Negative (NPN) logic.

### **RESET** (input 12)

Input of RESET that executes the reset of the visualized count showed on display at the moment of its activation.

### **INHIBIT** (input 13)

Input of count inhibition: when activated it blocks the count of the normal counter and the totalizer.

### **RL1** (inputs 1 - 2)

Output of Relay 1, connected to the operation of the Set Point S1. The Common, Normally Open and Normally Close contacts are available.

### **RL2** (inputs 3 - 4)

Output of Relay 2, connected to the operation of the Set Point S2. The Common, Normally Open and Normally Close contacts are available.

## DESCRIPTION OF THE LED'S OPERATION

### **LED 1**

It comes activated to the reaching of the Set Points S1.

### **LED 2**

It comes activated to the reaching of the Set Points S2.

### **LED 1 (REAR)**

It signals the presence of the input signal.

## SET POINTS PROGRAMMATION

For SET POINT and HYSTERESIS programming access, proceed as follow:

- Press key 'PRG' in impulsive mode; on display appears:

|      |
|------|
| SG 1 |
| 1000 |

**SG.1 = SET POINT 1**, programmable between 0 and 9999.

|      |
|------|
| SG 2 |
| 100  |

**SG.2 = SET POINT 2**, programmable between 0 and 9999.

Key **ENT** confirms the data. In order to exit the programming, press key **PRG**.

## PROGRAMMING OF THE OPERATION PARAMETERS

The programmable parameters are divided in two groups and protect with a 4 figures code.

In order to approach the programming, proceed in the following way:

- Press key **PRG** for about 2 sec. On the display appears:

|     |
|-----|
| Cod |
| 000 |

**GROUP 1** : in order to approach the parameters of group 1, insert code **101** and press **ENT**

|      |
|------|
| F.M  |
| 0001 |

**F.M. = 4 digits multiplier** , programmable from 1 to 10000. This parameter allows to multiply the number of the input impulses, showing them on the display in an other format. If it programmed = 0 it means programmed 10000.

**Attention:** the variation of the value of the multiplying modifies automatically the value of the count and the totalizer.

|      |
|------|
| F.d  |
| 0001 |

**F.d. = 4 digits divisor**, programmable from 1 to 10000. This parameter allows to divide the number of the input impulses, showing them on the display in an other format. If it programmed = 0 it means programmed 10000.

**Attention:** the variation of the value of the multiplying modifies automatically the value of the count and the totalizer.

|      |
|------|
| b.t. |
| 60   |

**b.t. = Time Base.**

This programming allows to select in which time base shows on the display the measure in input. There are three scales:

**1 = Time Base: seconds**, measure visualization in seconds (ex. Meters/seconds)

**60 = Time Base: minutes**, measure visualization in minutes (ex. Liters/minutes)

**3600 = Time Base: hours**, measure visualization in hours (ex. Bottles/hour)

## PROGRAMMING OF THE OPERATION PARAMETERS

The programmable parameters are divided in two groups and protect with a 4 figures code.

In order to approach the programming, proceed in the following way:

- Press key **PRG** for about 2 sec. On the display appears:

|     |
|-----|
| Cod |
| 000 |

**GROUP 2** : in order to approach the parameters of **GROUP 2**, insert code **020** and press **ENT**

|       |
|-------|
| E. 01 |
|-------|

**E.i = Delay Time for the excitation of the Relay output1.**

This parameter allows to program the delay time of the activation of the Relay output RL1. It's programmable between 0 (no delay) and 9,9 sec.

|       |
|-------|
| d. 01 |
|-------|

**d.i = Delay Time for the unexcitation of the Relay output1.**

This parameter allows to program the delay time of the unactivation of the Relay output RL1. It's programmable between 0 (no delay) and 9,9 sec.

|         |
|---------|
| E.ii 01 |
|---------|

**E.ii = Delay Time for the excitation of the Relay output2.**

This parameter allows to program the delay time of the activation of the Relay output RL2. It's programmable between 0 (no delay) and 9,9 sec.

|         |
|---------|
| d.ii 01 |
|---------|

**d.ii = Delay Time for the unexcitation of the Relay output2.**

This parameter allows to program the delay time of the unactivation of the Relay output RL2. It's programmable between 0 (no delay) and 9,9 sec..

|         |
|---------|
| t.r. 10 |
|---------|

**t.r. = Reset time of the display.**

This parameter allows to program the maximum time from the last impulse after that the instrument reset the display, showing the four horizontal bars. If programmed = 0, with no impulses in input the instrument shows the last calculated value. If the programmed time is lower than the time between the impulses, the instrument shows the four horizontal bars. This parameter is useful to indicate when a plant is in stop or when there are no impulses in input or when the impulse source is damaged. It's programmable between 1 (instantaneous) and 99 seconds.

|         |
|---------|
| t.d. 01 |
|---------|

**t.d. = Updating time of the display.**

This parameter allows to program the delay time of the data adjournment on the display. It's programmable between 0 (instantaneous) and 9,9 sec

|      |
|------|
| In F |
| In S |

**Input Fast - Slow.**

This programming allows to set the count input to read signals coming from electromechanical contacts (relays, switches etc.) or from logical signals like proximity switches transistor and encoder.

**In = F.** sets the input to read digital signals up to 28 KHz.

**In = S.** sets the input to read electromechanical signals up to 25 Hz.

|      |
|------|
| rSou |
| rSon |

**Operation of the RESET Key;** this programming enable and disable the RESET working of the frontal RES key during the operation, as in the following modes:

**RS.ou.** = executes the RESET of the visualized parameter + the Relay Output

**RS.on.** = executes the RESET of the visualized parameter

**RS.oF.** = RESET working of the RES key excluded.

**RS.F.t.** = executes, at the same time, the RESET of the frequencymeter, of the totalizer and of the Relay Outputs

|       |
|-------|
| dP. 0 |
| dP. 4 |

**d.P. = Programming of the Decimal Point**

This programming allows to add a decimal point to the visualization on the 4 digits, in order to obtain counts with various resolutions.

**d.p. = 0** Decimal Point excluded; visualization 9999

**d.p. = 1** Decimal Point on the second display from right; visualization 999,9

**d.p. = 2** Decimal Point on the third party display from right; visualization 99,99

**d.p. = 3** Decimal Point on the fourth display from right; visualization 9,999

**d.p. = 4** Floating Point.

|        |
|--------|
| I. 001 |
|--------|

**I = Initial Time of inhibition of the activation of the Relay output.**

This parameter allows to inhibit the activation of the relay output for the time sets. During this time the relay output is excluded. It's operation follows the programming in **Ut.** under the code **121.** It's programmable between 0 (excluded) and 999 sec.

|     |    |
|-----|----|
| AP. | P. |
| AP. | r. |

**A.P. = Activation omde of the programmed parameters.**

With this programming is possible to activate the executed programmings directly to the exit of the programming or, when exited of the programming, after a RESET (with frontal key or from rear input).

**A.P. = P.** Activation of the parameters to the exit of the programming.

**A.P. = r.** Activation of the parameters to the exit of the programming after a RESET.

## PROGRAMMING OF THE OPERATION PARAMETERS

The programmable parameters are divided in two groups and protect with a 4 figures code.

In order to approach the programming, proceed in the following way:

- Press key **PRG** for about 2 sec. On the display appears:

|     |
|-----|
| Cod |
| 000 |

**GROUP 3** : in order to approach the parameters of GROUP 3, insert code **121** and press **ENT**

|      |
|------|
| Md 0 |
|------|

**Md. = Programming of the operation Mode**

This programming allows to program the operation mode of the Set Points, of the Hysteresis and of the Relay Outputs.

**Md. = 0** Two Lower Set Points (RL1 and RL2 excited under the Set Point value)

**Md. = 1** Two Upper Set Points (RL1 and RL2 excited over the Set Point value)

**Md. = 2** Upper Set Point + Lower Set Point (RL1 excited Over the Set Point value and RL2 excited under the Under the Set Point value)

**Md. = 3** Two Lower Set Points + maintained relay (RL1 and RL2 excited even Over the Set Points values; they can be reset after a RESET command or switching OFF and ON the instrument).

**Md. = 4** Two Upper Set Points + maintained relay (RL1 and RL2 excited even Under the Set Points values; they can be reset after a RESET command or switching OFF and ON the instrument).

**Md. = 5** One Upper Set Point and one Lower Set Point + maintained relay (the RL1 relay is always excited even Under the Set Point value and the RL2 relay is always excited even Over the Set Point value . It can be reset with a RESET command or switching OFF and ON the instrument).

|       |
|-------|
| Ut. 0 |
|-------|

**Ut. = Programming of the RESET Input and of the operation of the INHIBIT time.**

This programming allows to select the operation of the RESET input and the operation mode of the Inhibit time.

**Ut. = 0** Reset of the visualized value + relay (with inhibit time at the starting)

**Ut. = 1** Frequency Reset only + relay (with inhibit time at the starting)

**Ut. = 2** Frequency Reset + totalizer (at the same time) + relay (with inhibit time at the starting)

**Ut. = 3** Reset of the visualized value + relay (with inhibit time with the first impulse)

**Ut. = 4** Frequency Reset only + relay (with inhibit time with the first impulse).

**Ut. = 5** Frequency Reset + totalizer (at the same time) + relay (with inhibit time with the first impulse).



## CONNECTIONS

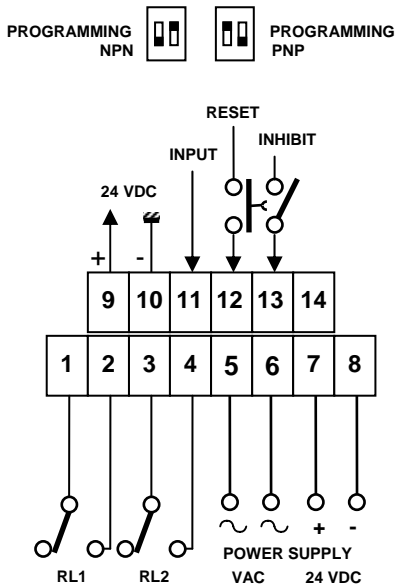

## INPUT SIGNALS

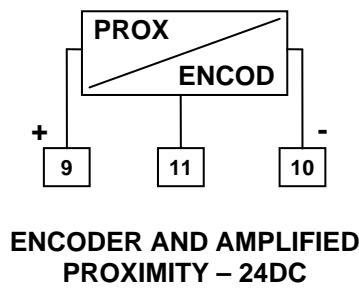

ENCODER AND AMPLIFIED PROXIMITY – 24DC

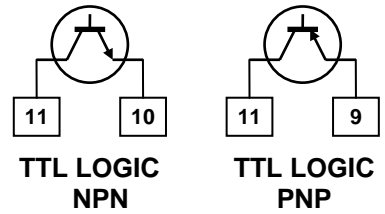

TTL LOGIC NPN

TTL LOGIC PNP

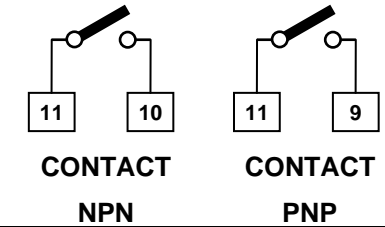

CONTACT NPN

CONTACT PNP

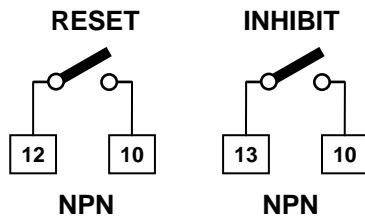

RESET NPN

INHIBIT NPN

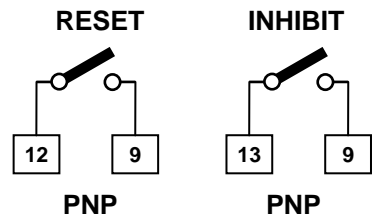

RESET PNP

INHIBIT PNP

## DIMENSIONS

### FRONT

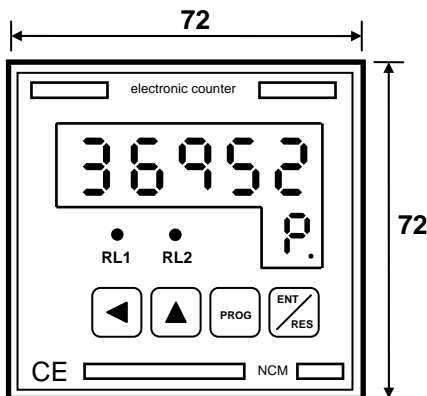

### SIDE

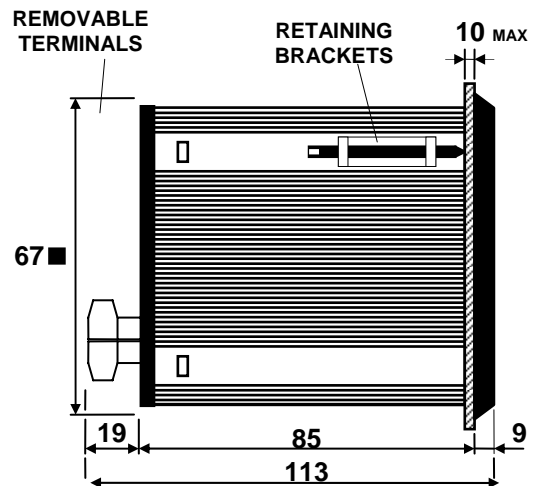

### REAR

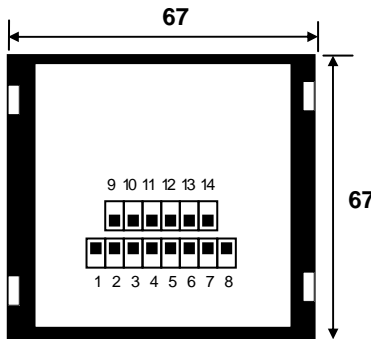

### DRILL TEMPLATE

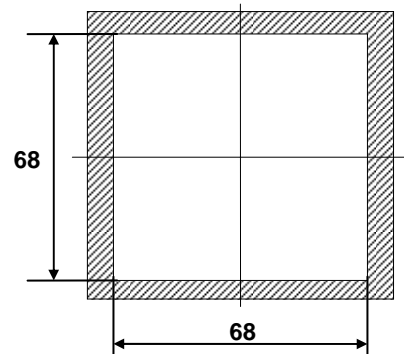

ACS-CONTROL-SYSTEM GmbH

Lauterbachstraße 57 ½  
 84307 Eggenfelden  
 Tel: 0 87 21/ 96 68-0  
 Fax: 0 87 21/ 96 68-30  
 e-mail: [info@acs-controlsystem.de](mailto:info@acs-controlsystem.de)  
 internet: [www.acs-controlsystem.de](http://www.acs-controlsystem.de)

Agent: