



VISUALIZED DIGITAL TIMER WITH ONE SET POINT

Typ:
NTM52E0
Stand 08/02

THE INSTRUMENTS OF SERIES **NTM** ARE DIGITAL INSTRUMENTS WIDE USABLE IN THE INDUSTRY FOR THEIR PROGRAMMABLE CHARACTERISTICS AND THE FLEXIBILITY OF THEIR EMPLOYMENT.

NTM52, TIMER WITH ONE PROGRAMMABLE SET POINT AND TWO RELAY OUTPUTS. MOREOVER, IT'S AVAILABLE A TOTALIZER OF THE TIME.

Bauform 72 x 72 mm



GENERAL FEATURES

- Frontal keyboard in polycarbonate (antiscratch, antioil, antacid).
- IP65 protection degree
- Accessible parameters with key software
- Removable terminals connection.
- Execution DIN 72 x 72.
- Recessed assembly.
- Special retaining brackets.

PROGRAMMABLE PARAMETERS

- One Set Point
- Automatic Time Reset
- 4 Time Scales
- UP / DOWN / SUPERIOR Timing
- Memory
- Reset Key
- START Input Selection
- OUTPUT Mode Selection

TECHNICAL CHARACTERISTICS

- | | |
|---------------------------------------|--|
| • POWER SUPPLY IN ALTERNATING CURRENT | : Single power 24 - 110 - 230 Vac (50 / 60 Hz). |
| • POWER SUPPLY IN CONTINUUM CURRENT | : Single power 24 Vdc |
| • POWER SUPPLY TOLERANCE | : +10% - 15%. |
| • ABSORPTION | : 2 W - 3 VA. |
| • OPERATING TEMPERATURE | : -5 °C + 55 °C. |
| • CLIMATIC CONDITIONS | : U.R. 95 % at 40 °C (without condensate). |
| • TIMINGS VISUALIZATION | : 5 digits, 11 mm high |
| • TIMINGS SCALES | : 999h59m - 9h59m59s - 9m59s99c - 999s99c |
| • START INPUT | : programmable as Continuous; Impulsive, Start/Stop |
| • AUXILIARY INPUTS POWER SUPPLY | : 24 Vdc - 80 mA available on terminals. |
| • COMMAND INPUTS | : 1 Start - 1 Reset Timing - 1 Inhibit Timing (Inhibit). |
| • OUTPUTS | : 2 relays; capacity 2A - 250Vac. |
| • RELAY RESET | : Manual or automatic with excitation time from 0,1 to 99,9 sec. |
| • PROGRAMMED DATA MEMORY | : static (without battery) |

DESCRIPTION OF THE FRONTAL KEYBOARD

 **WHITE**

The key '**LEFT ARROW**' in normal operating phase visualizes, blinking, all the programmings executed without the limitation of the insertion code. The time of scansion of the programmings is given from the pressure of the same key. It exits automatically from this phase after 5 sec of the last pressure of the same key.
In programming phase it moves the cursor of the figure towards left of a step, than at the beginning it is on the right side first one on the. At the end it resumes from the first one to right.

 **WHITE**

The key '**UP ARROW**' in normal operating phase it enter and exit to the Totalizer.
In programming phase it increases the value of the blinking figure.

 **WHITE**

The key '**PRG**' pressed for 2 sec. allows to enter in the programming phase, visualizing on display C.0000.
In the programming phase, pressing key 'PRG' impulsively, it exits from the programming phase. The instrument exits automatically from the programming phase, 60 sec. after the pressure of the last key.

 **RED**

The key '**ENT/RES**' in normal phase of counting has the 'RESET' function, with the modalities to it attributed in the programming phase.
In programming phase it confirms and memorizes the visualized data and passes to the successive function. If it has arrived to list end it resumes from the beginning.

INPUTS / OUTPUTS DESCRIPTION

DC POWER SUPPLY
(inputs 7 - 8)

24VDC Power Supply Input of the instrument.

AC POWER SUPPLY
(inputs 5 - 6)

AC Power Supply Input of the instrument; it can be to 24 - 110 - 230 VAC in according to demand.

24 VDC - 80mA
(inputs 9 - 10)

24 VDC – 80 mA auxiliary Power Supply that the instrument supply to feed the Encoder and amplified proximity.

START
(input 11)

START Input that execute the timing starting as the programming mode; it's configurable in Positive (PNP) or Negative (NPN) logic by the dip switches on the rear.

RESET
(input 12)

RESET Input that execute the timing reset; it's configurable in Positive (PNP) or Negative (NPN) logic by the dip switches on the rear.

INHIBIT
(input 13)

INHIBIT Input that execute the timing Inhibit; it's configurable in Positive (PNP) or Negative (NPN) logic by the dip switches on the rear.

RL1
(inputs 1 - 2 - 3)

Output of Relay 1, connected to the operation of the Set Point S1. The Common, Normally Open and Normally Close contacts are available.

RL2
(inputs 3 - 4)

Output of Relay 2, connected to the operation of the Set Point S2. The Common, Normally Open and Normally Close contacts are available.

DESCRIPTION OF THE LED's OPERATION

LED 1

It comes activated to the reaching of the Set Points S1.

LED 2

It comes activated to the reaching of the Set Points S2.

SET POINTS PROGRAMMING

For SET POINTS programming access, proceed as follow:

- Press key 'PRG' in impulsive mode; on display appears:

S.1
0. 00. 20

S.1 = SET POINT 1, main Set Point, programmable between 1 cent and 999h59m (depending to the selected scale). If programmed = 0 the Set Point is excluded and the instrument works like a totalizer and predisposes the count in UP mode.

S.2
0. 00. 20

S.2 = SET POINT 2, main Set Point, programmable between 2 cent and 999h59m (depending to the selected scale). If programmed = 0 the Set Point is excluded and the instrument works like a totalizer and predisposes the count in UP mode.

Key **ENT** confirms the data and passes to the successive programming. In order to exit the programming, press key **PRG**.

PROGRAMMING OF THE OPERATION PARAMETERS

The programmable parameters are divided in two groups and protect with a 4 figures code.

In order to approach the programming, proceed in the following way:

- Press key **PRG** for about 2 sec. On the display appears:

Cod
0000

GROUP 1 : in order to approach the parameters of group 1, insert code **2357** and press **ENT**

t.r. 99.9

t.r. = Time of Automatic Reset, programmable from 0.0 to 99.9 sec. This parameter allows to make to work the instrument in **automatic** mode. When the timing arrives to the value of S.1, it automatically resets the count, excites the RL1 relay and it resumes to count. The RL1 relay remains excited for the set up time in t.r. If the time of reset is programmed = 0 (0.0) the instrument gets ready to works in **manual** mode.

Particular cases: if the set up time t.r. is bigger than the time employed to the timing to arrive to the values of S.1, the relay will never come unactivated.

SCL. 1

SCL. = Time Scale. Selection of the maximum time scale of the timing. It's possible to choose between 4 different time scales:

1 = 9m59s99c - 2 = 9h59m59s - 3 = 999h59m - 4 = 999s99c

Cn UP
Cn dn
Cn Sp.

Count UP / DOWN / Superior.

Count = Up: Up; the timer gets ready to visualize the timing in increasing way (UP), starting from zero up to the programmed value of set point. To the end of timing it works in Manual or Automatic mode, as programmed in t.r. function.

Count = dn: Down; the timer gets ready to visualize the timing in decreasing way (DOWN), starting from the programmed value of set point to zero. To the end of timing it works in Manual or Automatic mode, as programmed in t.r. function.

Count = Sp: Superior; the timer gets ready to visualize the timing in increasing way (UP), starting from zero up to the programmed value of set point. To the end of timing it works in Manual mode and the timing goes on up to a new command (START, RESET, INHIBIT).

PROGRAMMING OF THE OPERATION PARAMETERS

The programmable parameters are divided in two groups and protect with a 4 figures code.

In order to approach the programming, proceed in the following way:

- Press key **PRG** for about 2 sec. On the display appears:

Cod
0000

GROUP 2 : in order to approach the parameters of group 1, insert code **2413** and press **ENT**

MEMon
MEMof

Active or excluded memory.

This parameter allows to program the saving of the current counter value during the power off the instrument.

MEM.on. = memorization of the count during the power off. When power on the instrument the display will visualize the last present value in the power off phase.

MEM.of. = excluded memorization of the count; every time that the instrument comes powered off and then powered on the count comes lost and the instrument restart always from the initial condition.

RES 0
RES 3

Function of RESET Key ; this programming enable and disable the RESET function of the RES frontal key during the normal timing:

RES. 0 = RESET function of the RES key disabled

RES. 1 = RESET function of the principal timing only

RES. 2 = RESET function of the global timing only

RES. 3 = RESET function of the principal and global timings

In I.
In C.
In S.

Programming of the START Input.

This programming allows to Start the timing in three different modes:

In. I. = Impulsive Mode; the timing starts with the impulsive closing of the START input.

In. C. = Continuously Mode; the timing starts with the closing of the START input; the timing is interrupted every time the START input comes opened.

In. S. = Start/Stop Mode; the timing starts with the impulsive closing of the START input and it stops to the subsequent closing. Closing another time the input the timing resume and it stops to the subsequent closing.

Auto I.
Auto F.

Programming of the Automatic Reset Mode

This parameter allows to activate the timing to the beginning or the end of the programmed time of the Automatic Reset.

Auto I. = Activation of the timing to the beginning of the Automatic Reset Time

Auto F. = Activation of the timing to the end of the Automatic Reset Time

Ou U-
Ou I-

Programming of the OUTPUT RL1. This parameter allows to activate the RL1 relay during the timing or at the end of the timing.

Ou.1. = Activation of the RL1 relay at the end of the timing

Ou.1. = Activation of the RL1 relay during the timing

AP. P.
AP. r.

Activation mode of the programmed parameters.

With this programming is possible to activate the executed programmings directly to the exit of the programming or, when exited of the programming, after a RESET (with frontal key or from rear input)

A.P. = P. Activation of the parameters to the exit of the programming.

A.P. = r. Activation of the parameters to the exit of the programming after a RESET.

Pressing the key the totalizer of time will be visualized for 5 sec.

tot.
00000

The totalizer visualizes the total time that the instrument has show.

It can be resetted through frontal key RES or from RESET input when it is visualized on the display.

CONNECTIONS

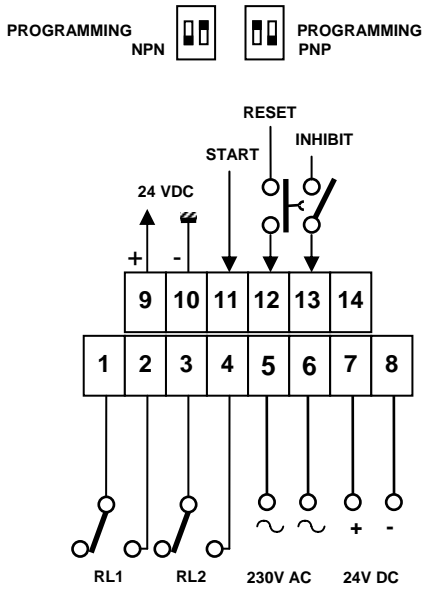

INPUT SIGNALS

START

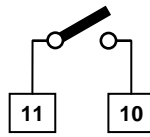

CONTACT
NPN

START

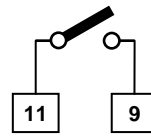

CONTACT
PNP

START

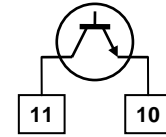

TTL LOGIC
NPN

START

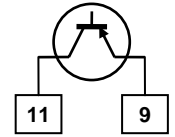

TTL LOGIC
PNP

RESET

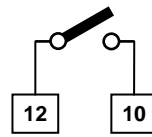

NPN

INHIBIT

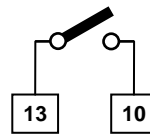

NPN

RESET

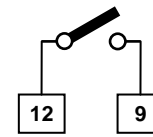

PNP

INHIBIT

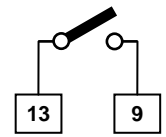

PNP

OVERAL DIMENSIONS (mm)

FRONT

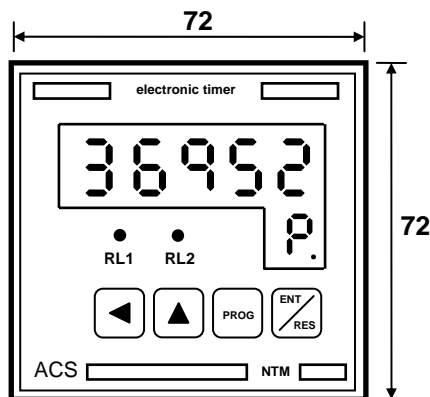

SIDE

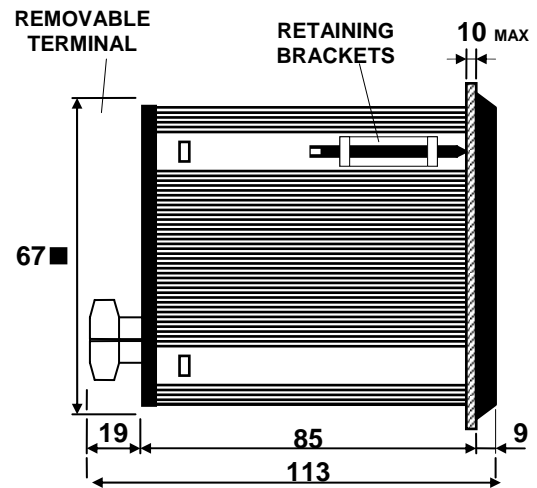

REAR

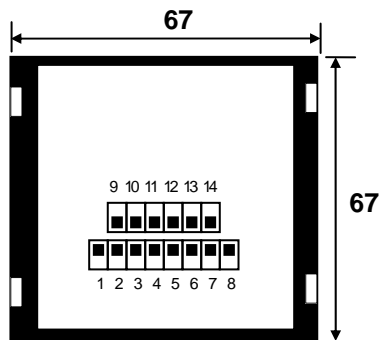

DRILL
TEMPLATE

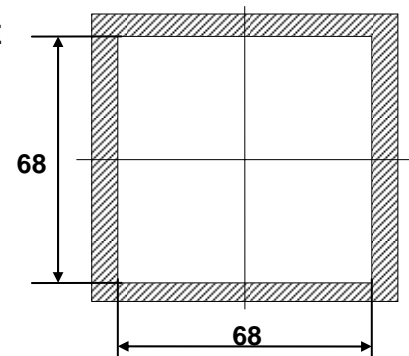

ACS-Control-System GmbH
Lauterbachstr. 57
D- 84307 Eggenfelden

Tel: +49 (0) 8721-9668-0
Fax: +49 (0) 8721-9668-30

info@acs-controlsystem.de
www.acs-controlsystem.de

ACS-CONTROL-SYSTEM
knowledge and systems



Your partner for measuring technology and automation