



VISUALIZED DOUBLE FREQUENCYMETER WITH TWO ANALOG OUTPUTS

Type:
VFM
240 AN64 AE

The **VFM 240 AN64 AE** instrument is a double frequencymeter that calculate continually the impulses frequency of the two inputs and displays the two frequencies and theirs difference and give to the outputs a direct current referred to the frequency showed.

For its characteristics and versatility this instrument can be used as tools counter, speed survey and where is necessary to control linear speed or rotation speed of motor trees with an external system.



GENERAL FEATURES

- Front push-button panel made of polycarbonate (antiscratch, oil and acid resistant).
- Protection grade IP 65.
- Access to parameters with software key.
- Removable terminal connections.
- DIN 96 X 96 execution.
- Recessed assembly.
- Special retaining brackets.





PROGRAMMABLE PARAMETERS

- Inputs multiplier factor (channel 1 and 2).
- Inputs division factor (channel 1 and 2).
- Automatic reset time.
- Refresh display time.
- Input selection (Fast-Slow).
- 2 Analog outputs selection.
- 2 Analog Initial Scale.
- 2 Analog Full Scale.

TECHNICAL FEATURES

- POWER SUPPLY IN ALTERNATE CURRENT : 24 - 110 - 230 Vac (50 / 60 Hz).
- POWER SUPPLY TOLERANCE : +10% - 15%.
- ABSORPTION : 2 W - 3 VA.
- OPERATING TEMPERATURE : -5 °C + 55 °C.
- CLIMATIC CONDITIONS : U.R. 95 % a 40 °C (without condense).
- COUNTER AND TOTALIZER VISUALIZATION : 4 digits for frequencies and 3 digits for the difference.
- MULTIPLICATION FACTOR FOR F1/F2 INPUT IMPULSES : from 1 to 10000.
- DIVISOR FACTOR FOR F1/F2 INPUT IMPULSES : from 1 to 10000.
- COUNTING INPUTS : 2 for Electromechanical or Logic Inputs - NPN and PNP
- REFRESH DISPLAY TIME : programmable between 0 and 9,9 sec.
- MAXIMUM FREQUENCY FOR DIGITAL IMPULSES : from 0,1 Hz to 5 KHz.
- MINIMUM TIME FOR ELECTROMECHANICAL IMPULSES : 8 Hz about.
- OUTPUTS : 4 - 20 mA for both the outputs
- CONVERTER RESOLUTION : 16 bit
- FREQUENCY PRECISION : 0,1 % (worst case).
- AUXILIARY INPUT SUPPLY : 12 Vdc - 80 mA available on the terminal 5-6
- PROGRAMMED DATA MEMORY : static (no battery).

DESCRIPTION OF THE FRONTAL KEYBOARD

 WHITE	In programming phase it moves the cursor of the figure towards left of a step, than at the beginning it is on the right side first one on the. At the end it resumes from the first one to right.
 WHITE	In programming mode it increases the blinking digit. In normal mode it switches the F1 / F2 visualization on the display. L1 and L2 Led show the two frequencies.
 WHITE	Pressed for 2 sec. allows to enter in the programming phase, visualizing on display C.0000. In the programming phase, pressing key 'PRG' impulsively, it exits from the programming phase. The instrument exits automatically from the programming phase, 60 sec. after the pressure of the last key.
 RED	In normal phase of counting has the 'RESET' function. In programming phase it confirms and memorizes the visualized data and passes to the successive function. If it has arrived to list end it resumes from the beginning.

INPUTS / OUTPUTS DESCRIPTION

DC POWER (input 1-2)	24V AC Power Supply of the instrument.
AC POWER (input 1-3)	110 VAC Power Supply of the instrument.
AC POWER (input 1-4)	230 VAC Power Supply of the instrument.
12 VDC - 80mA (input 5 - 6)	12 VDC - 80 mA auxiliary Power Supply that the instrument supply to feed the Encoder and amplified proximity.
INPUT 2 (input 7)	Counting input 2, fit for electromechanical and logical contacts, encoder and 3 wires proximity amplified, configurable in Positive (PNP) and Negative (NPN) logic by the dip switches on the rear.
INPUT 1 (input 8)	Counting input 1, fit for electromechanical and logical contacts, encoder and 3 wires proximity amplified, configurable in Positive (PNP) and Negative (NPN) logic by the dip switches on the rear.
A OUT 2 (input 1 - 2 upper connector)	4 - 20 mA Analog Output 2, referred to the programming under code 020.
A OUT 1 (input 4 - 5 upper connector)	4 - 20 mA Analog Output 1, referred to the programming under code 020.

DESCRIPTION OF THE DISPLAY AND LED'S OPERATION

LED +	It's ON when the F2 - F1 difference is positive.
LED -	It's ON when the F2 - F1 difference is negative.
LED 1	L1 It's ON when F1 frequency is displayed.
LED 2	L2 It's ON when F2 frequency is displayed.
LED 1 (REAR)	It signals the presence of the input signal 2, Frequency 2
LED 2 (REAR)	It signals the presence of the input signal 1, Frequency 1

PROGRAMMING OF THE OPERATION PARAMETERS

The programmable parameters are divided in two groups and protect with a 4 figures code.

In order to approach the programming, proceed in the following way:

- Press key **PRG** for about 2 sec. On the display appears:

000

Cod

GROUP 1 : in order to approach the parameters of group 1, insert code **101** and press **ENT**

000 1

M.F. 1

M.F. 1 = 4 digits multiplier, programmable from 1 to 10000. This parameter allows multiplying the number of the input impulses of channel 1, showing them on the display in another format. If it programmed = 0 it means programmed 10000.

000 1

d.F. 1

d.F. 1 = 4 digits divisor, programmable from 1 to 10000. This parameter allows to divide the number of the input impulses of channel 1, showing them on the display in another format. If it programmed = 0 it means programmed 10000.

000 1

M.F. 2

M.F. 2 = 4 digits multiplier, programmable from 1 to 10000. This parameter allows to multiply the number of the input impulses of channel 2, showing them on the display in another format. If it programmed = 0 it means programmed 10000.

000 1

d.F. 2

d.F. 2 = 4 digits divisor, programmable from 1 to 10000. This parameter allows to divide the number of the input impulses of channel 1, showing them on the display in another format. If it programmed = 0 it means programmed 10000.

PROGRAMMING OF THE OPERATION PARAMETERS

The programmable parameters are divided in two groups and protect with a 4 figures code.

In order to approach the programming, proceed in the following way:

- Press key **PRG** for about 2 sec. On the display appears:

000	GROUP 2 : in order to approach the parameters of group 1, insert code 020 and press ENT
Cod	
99	t.r. = Delay Time for Automatic Reset of the display (no input impulses) programmable between 1 and 99; if it is set to 0 the automatic reset is disabled. If the reset delay time is lower than the time between two impulses, there will be no visualization.
t.r.S	
01	d.d. 0,1 = Delay Display. Time delay to updating the display. This parameter, programmable between 1 and 99, allows to program the updating of the value on the display.
dd	
Slow	In Fast/Slow = This parameter allows to choose the input speed of the two frequencies. Slow = select the two inputs up to 8 Hz (electromechanical switches) Fast = select the two inputs up to 5 KHz (logical signals)
FAST	
In	d.S. 2 = Selection of the visualization on the 3 digits display. Frq. 1 = visualization frequency 1 Frq. 2 = visualization frequency 2 diFF. = visualization difference of F2 – F1
Frq 1	
Frq 2	
dS2	An. 1 = Select the measure on the Output 1: Frq. 2 = Frequency of Channel 2 diFF. = Difference F2 - F1
Frq 2	
Frq 1	
An1	An. 2 = Select the measure on the Output 2: Frq. 1 = Frequency of Channel 1 Frq. 2 = Frequency of Channel 2
Frq 1	
Frq 2	
An2	I.S. 1 = Initial Scale of the Output 1 This programming select the value corresponding to the Initial Scale of the Analog Output 1. It's programmable between 0 and 65536.
65536	
I.S.1	
65536	F.S. 1 = Full Scale of the Output 1 This programming select the value corresponding to the Full Scale of the Analog Output 1. It's programmable between 0 and 65536.
F.S.1	
65536	I.S. 2 = Initial Scale of the Output 2 This programming select the value corresponding to the Initial Scale of the Analog Output 2. It's programmable between 0 and 65536.
I.S.2	
65536	F.S. 2 = Full Scale of the Output 2 This programming select the value corresponding to the Full Scale of the Analog Output 2. It's programmable between 0 and 65536.
F.S.2	

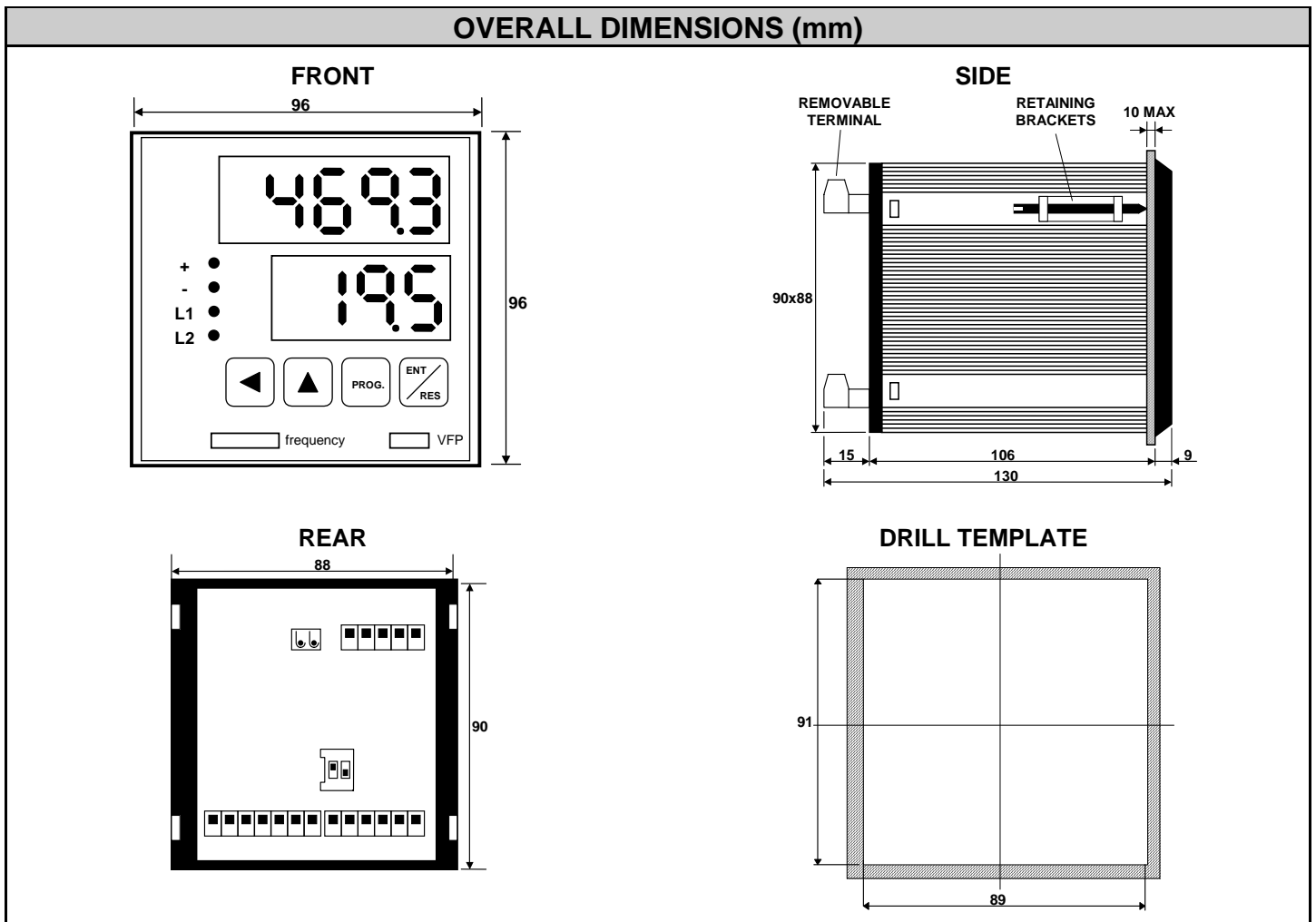
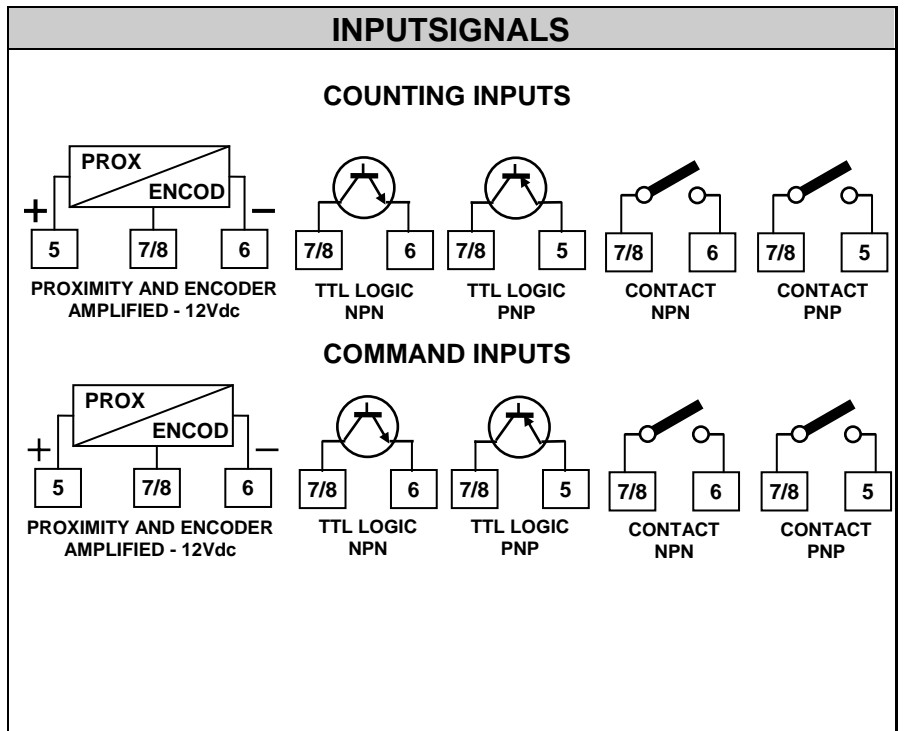
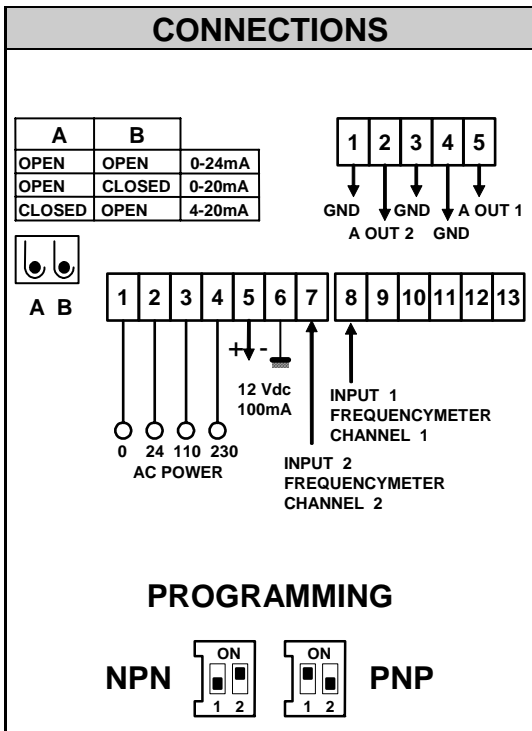

ACS-Control-System GmbH
Lauterbachstr. 57
D- 84307 Eggenfelden

Tel: +49 (0) 8721-9668-0
Fax: +49 (0) 8721-9668-30

info@acs-controlsystem.de
www.acs-controlsystem.de

ACS-CONTROL-SYSTEM
knowledge and systems



Your partner for measuring technology and automation