

Technical manual BA 0509



Signal converter

TVA – 080 / 100 / 120 / 180 / 200 / 220 Isolation amplifier – active

for galvanic isolation, conversion and
adjustment of electrical standard signals

Evaluable input signals

- Direct voltage 0...10V / 0...1V / -5...+5V / -0,5...+0,5V
- Direct current 0...20mA / 4...20mA / -10...+10mA
- Pulse frequency modulated (PFM) current signal 90...520Hz

Output signals

- Direct voltage 0...10V / 2...10V – simultaneous outputs
- Direct current 0...20mA / 4...20mA - simultaneous outputs

Signal adjustment of zero value and amplification – optional

Single or double channel version – optional

Integrated measurand transducer supply – optional

Space saving safe isolation with 4kV~

Wide range power supply from 20 to 253V AC and DC

ACS-CONTROL-SYSTEM
know how mit system



Lauterbachstr. 57 – 84307 Eggenfelden – Germany
Tel: +49 8721/9668-0 – Fax: +49 8721/9668-30
info@acs-controlsystem.de – www.acs-controlsystem.de

Index

Order code	2
Application	3
Function	3
Safety notes	4
Installation	4
Maintenance	4
Repair	4
Electrical connection	5 / 6
Operation and display elements	7
Technical data	8

	TVA – 080 – U0	TVA – 180 – U0	TVA – 100 – U0	TVA – 120 – U0	TVA – 200 – U0	TVA – 220 – U0
Fix adjusted version		X		X		X
Adjustable version	X		X		X	
Measurand transducer supply			X	X	X	X
Single channel version	X	X	X	X		
Double channel version					X	X

Order code

- TVA – 080 – U0 Version single channel device, adjustable
- TVA – 100 – U0 Version single channel device, adjustable, with measurand transducer supply
- TVA – 180 – AB – U0 Version single channel device, fix adjusted
- TVA – 120 – AB – U0 Version single channel device, fix adjusted, with measurand transducer supply

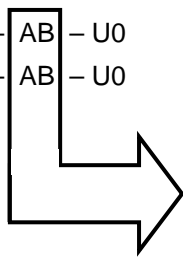

Input	code no. A
0...10V	1
0...20mA	2
4...20mA	3
90...520Hz – PFM	P
special range	Y

Output	code no. B
0...10V	1
0...20mA	2
4...20mA	3
special range	Y

- TVA – 200 – U0 Version double channel device, adjustable, with measurand transducer supply
- TVA – 220 – ABCD – U0 Version double channel device, fix adjusted, with measurand transducer supply

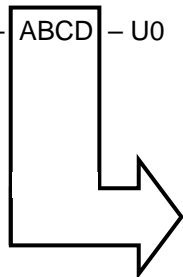

Input 1	order no. A
0...10V	1
0...20mA	2
4...20mA	3
special	Y

Input 2	order no. B
0...10V	1
0...20mA	2
4...20mA	3
special	Y

Output 1	order no. C
0...10V	1
0...20mA	2
4...20mA	3
special	Y

Output 2	order no. D
0...10V	1
0...20mA	2
4...20mA	3
special	Y

Application

The active isolation amplifier of the series **TVA** is used, dependent on version, for galvanic isolation of electrical standard signals 0..10V / 0..1V / -5..+5V / -0,5..+0,5V / 0..20mA / 4..20mA / -10..+10mA or a pulse frequency modulated (PFM) current signal 90...520Hz or for convert it into another standard signal or to adjust the signals in the zero value and/or end value resp. amplification.

A galvanic isolation is sometimes the only possibility at error generating ground loops, unwished signal overlapping and potential problems.

Thus, a current flow between more signal current circuits that distort the signal is avoided.

The free configurable resp. fix signal conversion, dependent on version, allows the flexible adaption of different systems among each other, e.g. for connection of a 2-wire-measurand transducer with a current signal 4...20mA to the input 0...10V of a SPS control.

The adjustable version is suitable, if sections, e.g. 5...14mA of a standard signal 4...20mA at the input should amplified to a complete standard signal e.g. 4...20mA or e.g. for zero value adjustment of a fix adjusted measurand transducer e.g. because of a position dependent zero value shifting.

At the versions TVA – 200 – U0 / TVA – 220 – U0 in one device there can be two electrical signals simultaneous transmitted separately or one electrical standard signal can be doubled into two separated electrical standard signals by parallel or series connection.

The signal input for pulse frequency modulated (PFM) current signal 90...520 Hz in combination with corresponding measurand transducer resp. signaling transmitter is especially suited for long transmission links of several 1000 m. The special type of the signal makes in insensitive against the negative characteristics of cables, that occurs only at higher length, like e.g. resistance and inductivity as well as error current through the isolation.

Function

Measuring principle

Version TVA – 080 – U0 / TVA – 100 – U0 / TVA – 200 – U0 – adjustable version

The connected electrical standard signal 0..10V / 0..1V / -5..+5V / -0,5..+0,5V / 0..20mA / 4..20mA / -10..+10mA is measured by the evaluation circuit, adjusted according to the front-sided trimmer and transmitted galvanically isolated to the simultaneous output signals 0...10V and 0...20mA or 2...10V and 4...20mA according to the settings of the internal configuration switches.

The respective current resp. voltage signals at the output can be used simultaneous. Therefore there are simultaneous 2 output signals at the single channel versions TVA – 080 – U0 / TVA – 100 – U0 and simultaneous 4 output signals at the double channel version TVA – 200 – U0 are available.

Examples:

- | | | | |
|------------------|-----------------|---|------------------------|
| ▪ TVA – 100 – U0 | Input signal: | 0...10V is converted to output signal: | 0...10V / 0...20mA |
| ▪ TVA – 100 – U0 | Input signal: | 5...18mA is converted to output signal: | 2...10V / 4...20mA |
| ▪ TVA – 200 – U0 | Input signal 1: | 0...10V is converted to output signal 1: | 0...10V / 0...20mA and |
| | Input signal 2: | 4...18mA is converted to output signal 2: | 2...10V / 4...20mA |

Version TVA – 120 – U0 / TVA – 180 – U0 / TVA – 220 – U0 – fix adjusted version

The connected electrical standard signal 0..10V / 0..20mA / 4..20mA or the pulse frequency modulated (PFM) current signal 90...520Hz (not for the version TVA – 220 – U0) is transmitted by the evaluation circuit galvanically isolated to the output signal 0...10V or 0...20mA or 4...20mA.

Examples:

- | | | | |
|------------------|-----------------|---|-------------|
| ▪ TVA – 120 – U0 | Input signal: | 0...10V is converted to output signal: | 0...10V |
| ▪ TVA – 120 – U0 | Input signal: | 90...520Hz is converted to output signal: | 4...20mA |
| ▪ TVA – 220 – U0 | Input signal 1: | 0...10V is converted to output signal 1: | 0...10V and |
| | Input signal 2: | 4...20mA is converted to output signal 2: | 0...20mA |

Measurand transducer supply

Version TVA – 100 – U0 / TVA – 120 – U0 / TVA – 200 – U0 / TVA – 220 – U0

The integrated measurand transducer supply allows the direct connection and thus the supply of 2-wire and 3-wire transmitter.

At the versions TVA – 200 – U0 / TVA – 220 – U0 the measurand transducer supply is two times available, one for each channel separately.

Version TVA – 080 – U0 / TVA – 180 – U0

A measurand transducer supply is not available.

Safety notes

Each person that is engaged with inauguration and operation of this device, must have read and understood this technical manual and especially the safety notes.

Installation, electrical connection, inauguration and operation of the device must be made by a qualified employee according to the informations in this technical manual and the relevant standards and rules.

The device may only be used within the permitted operation limits that are listed in this technical manual. Every use besides these limits as agreed can lead to serious dangers.

The device meets the legal requirements of all relevant EC directives. **CE**



Installation

The device is conceived for vertical installation on a standard fastening rail acc. to DIN EN 60715 TH 35-7,5 resp. TH 35-15.

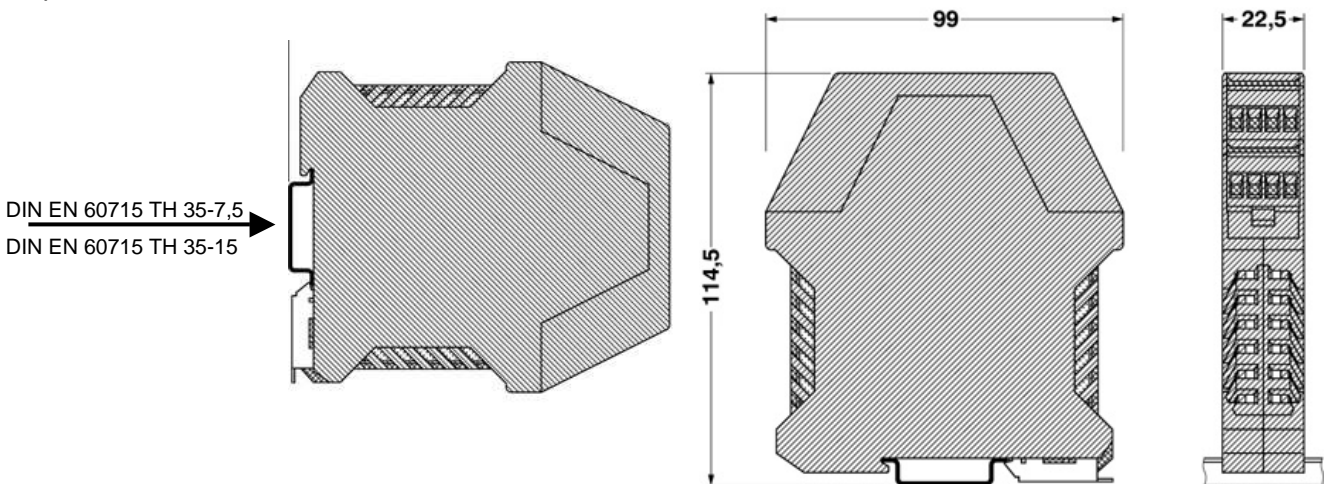

The device must be installed protected against dust and humidity, e.g. in control stations or in a suitable protection housing with a minimum protection classification IP55 acc. to DIN EN 60529.

The devices must be installed weather and stroke protected, ideally at places without direct solar radiation. This is especially important in warm climatic regions.

Maintenance

The device is free of maintenance.

Repair

A repair may only be carried out by the manufacturer. When sending back the device, add a note with the description of the error and the application.

Electrical connection

The electrical connection of the device must be carried out according to the respective country specific standards. Incorrect installation or adjustment could cause applicationally conditioned risks.

Power supply input, measuring input and signal output channels are safe galvanically isolated from each other. This is also valid for both measuring input and signal output channels among each other.

Connection of the signaling transmitter resp. measuring transducer – measuring inputs

For the two, three or four-wire connection cable between the isolation amplifier and the signaling transmitter resp. measuring transducer a standard installation cable or multi-wire cable for measuring intends with a maximum of 25 Ω per wire can be used.

The use of a shielded signal cable is recommended, if strong electromagnetic influences could happens, e.g. due to machines or radio equipment. In that case the shielding of the cable should be connected to earth only at the side of signaling transmitter resp. measuring transducer.

The signal cable should be installed separated from power leading wires.

The connected signaling transmitter resp. measuring transducer can be, dependent on version, powered by the integrated measuring transducer supply. The supply is overload and short circuit protected.

The maximum values of the inputs at the isolation amplifier (current input maximum 400mA - 30V / voltage input 50V) must not be transgressed. The current input is equipped with a self resetting fuse.

At activation of the fuse the signal current wire must be disconnected for app. 5 seconds.

Terminal occupation

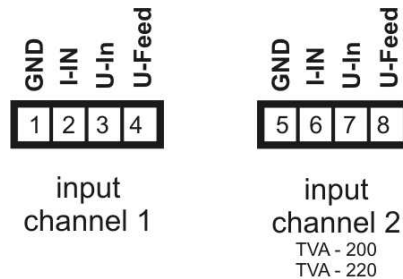

Connection scheme

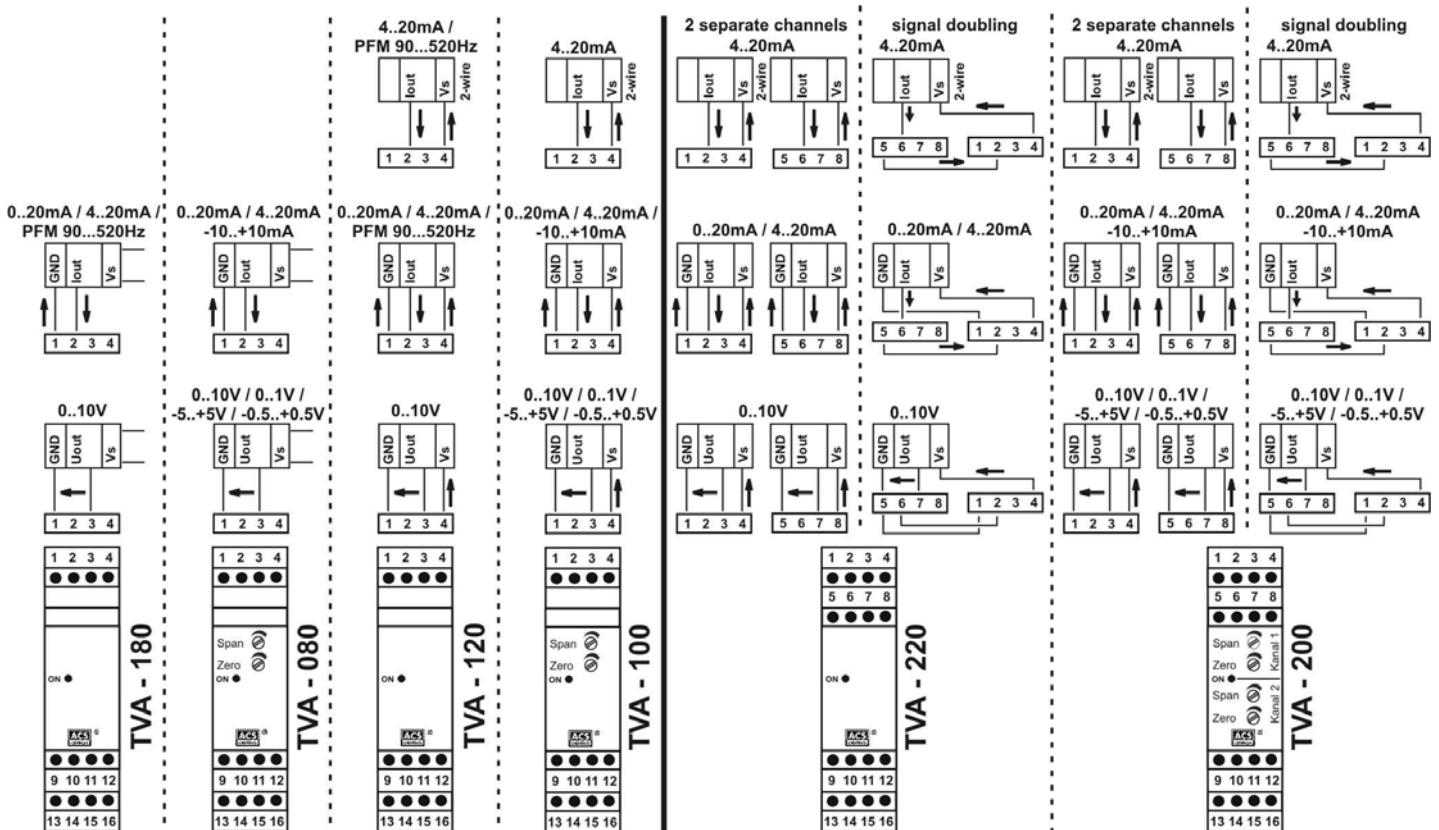

Electrical connection

Connection of the output

For the two-wire connection cable between the isolation amplifier and the connected devices a standard installation cable or multi-wire cable for measuring intends with a maximum of 25 Ω per wire can be used.

The use of a shielded signal cable is recommended, if strong electromagnetic influences could happens, e.g. due to machines or radio equipment. In that case the shielding of the cable should be connected to earth only at the side of the connected device. When connecting a SPS input stage there must be paid attention that mostly the signal circuit must be connected to earth by connection the minus terminal with measuring earth. The signal cable should be installed separated from power leading wires.

For inauguration it is suggested, to deactivate all connected control devices, to avoid unwanted control reactions.

Connection of the power supply voltage

Due to the integrated wide range power supply, for connection to supply voltages from 20...253V AC / DC, the isolation amplifier is suitable for using in all common energy supply networks.

The connection is reverse polarity protected.

A fuse is integrated internally at the power supply circuit. Due to this the installation of a fine protection is not necessary.

Terminal occupation

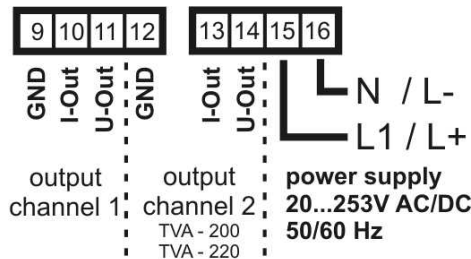

Connection scheme

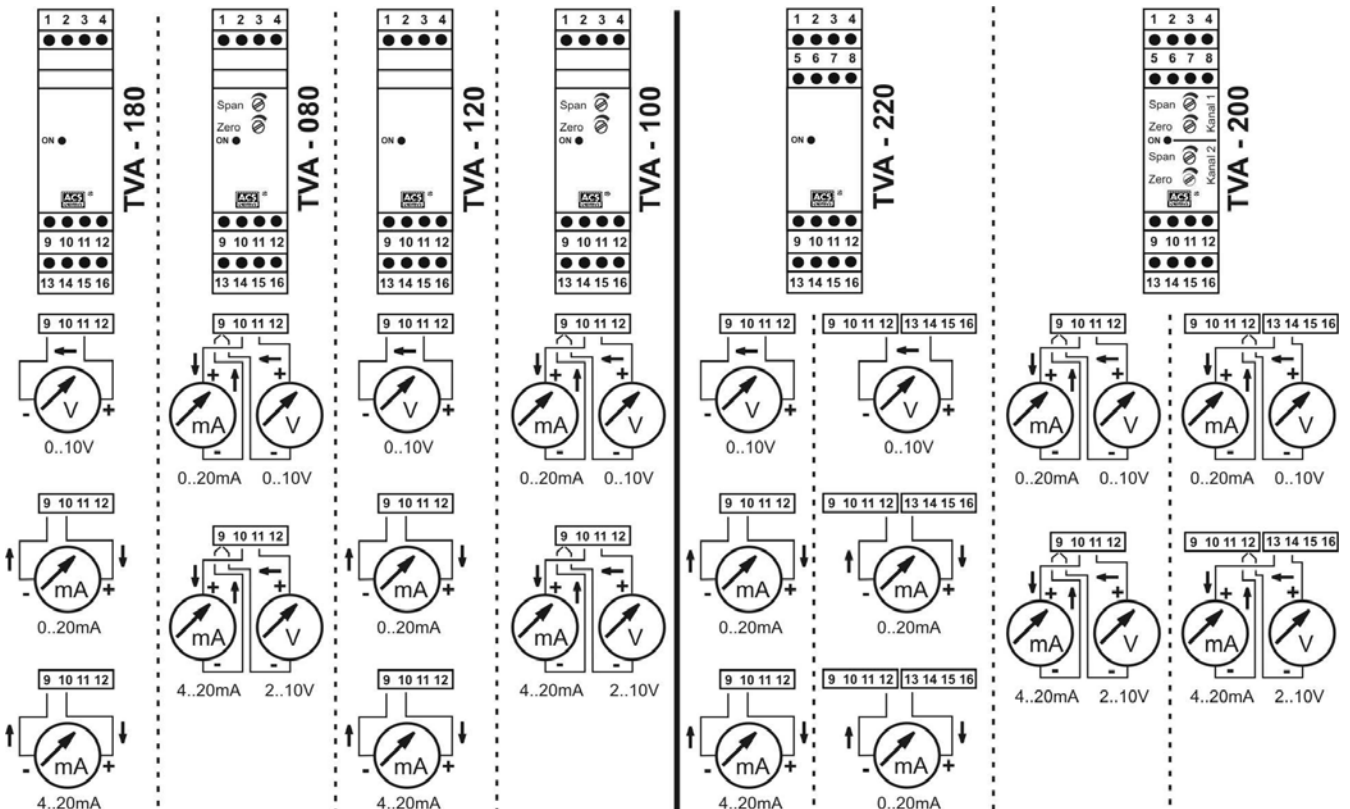

Operation and display elements

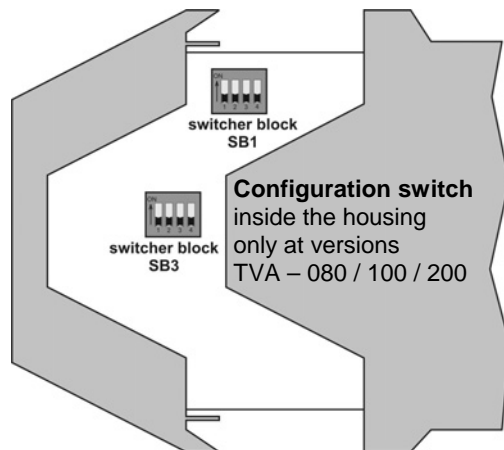
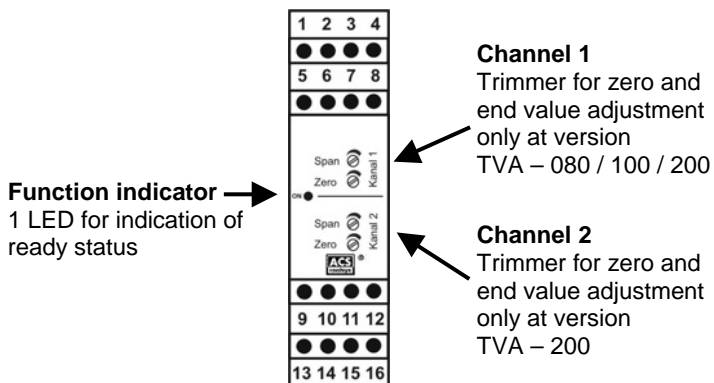

Function indicator

- ON → green LED → ready status, power supply voltage on

Trimmer

For adjustment of zero and end value per channel. Only available at versions TVA – 080 / 100 / 200.

For an accurate results the adjustment zero value – end value must be proceeded repeatedly with connected signal, because zero and end value adjustment effects each other.

Configuration switches

The configuration of the input and output signal ranges is made per dip switches inside the housing.



Dangerous voltage

Ensure a safe switching off the supply voltage when opening the housing

For configuration release the upper housing part at top and bottom side behind the terminals by using a screwdriver and pull it out of the housing. Drop-in pin's avoid a complete pulling out. Following the respective dip switches can be set according to the desired functions to ON or OFF.

Input signal range channel 1 switcher block SB1

Switch 1, 2, 3 (SB1) → measuring range

switching state S1	switching state S2	switching state S3	measuring range CH 1
OFF	ON	ON	-0,5...+0,5V / -10...+10mA
ON	OFF	OFF	4...20mA
OFF	OFF	ON	0...1V / 0...20mA
OFF	ON	OFF	-5...+5V / -10...+10mA
OFF	OFF	OFF	0...10V / 0...20mA

Input signal range channel 2 switcher block SB3

Switch 1, 2, 3 (SB3) → measuring range

switching state S1	switching state S2	switching state S3	measuring range CH 2
OFF	ON	ON	-0,5...+0,5V / -10...+10mA
ON	OFF	OFF	4...20mA
OFF	OFF	ON	0...1V / 0...20mA
OFF	ON	OFF	-5...+5V / -10...+10mA
OFF	OFF	OFF	0...10V / 0...20mA

Output signal range channel 1 switcher block SB1

Switch 4 (SB1) → signal range

switch	switching state ON	switching state OFF
4	0...10V / 0...20mA	2...10V / 4...20mA

Output signal range channel 2 switcher block SB3

Switch 4 (SB3) → signal range

switch	switching state ON	switching state OFF
4	0...10V / 0...20mA	2...10V / 4...20mA

Technical data

Auxiliary power supply

Permitted supply voltage:	20 V to 253 V AC / DC 48...62 Hz, reverse polarity protected
Power consumption:	≤ 3 VA / 1,5 W (TVA – 080 / 180) resp. ≤ 5 VA / 3 W (TVA – 100 / 120) resp. ≤ 7 VA / 5 W (TVA – 200 / 220)
Overvoltage category:	II acc. to DIN EN 61010-1
Protection classification:	II double or reinforced insulation
Isolation voltage:	4kV~ auxiliary power to signal inputs to signal outputs
Galvanic isolation:	All supply, input and output channels among each other as well as both input and output channels from each other are safe galvanically isolated.

Signal input (1x resp. 2x available, depends on version)

Direct voltage:	0...10 V / 0...1 V / -5...+5 V / -0,5...+0,5 V / max. 50V / input resistance 1,1MΩ		
Direct current:	0...20mA / 4...20mA / -10...+10mA / max. 400mA at 30V self resetting fuse / input resistance 25Ω + 0,2V		
PFM modulated current signal:	90...520 Hz, overlapping current pulse 5mA±10%, T _{Pulse} =110µs±20%		
Measurand transducer supply:	overload and short circuit protected		
▪ TVA – 100 / 120	3- wire-sensor: ≥ 19,2V at 20mA	≥ 18,8V at 27,5mA	min. 27,5mA / max. 25V
	2- wire-sensor: ≥ 18,8V at 20mA	≥ 18,4V at 27,5mA	min. 27,5mA / max. 25V
▪ TVA – 200 / 220	3- wire-sensor: ≥ 18,1V at 20mA	≥ 18,0V at 22,5mA	min. 22,5mA / max. 25V
	2- wire-sensor: ≥ 17,8V at 20mA	≥ 17,6V at 22,5mA	min. 22,5mA / max. 25V

Signal output (1x resp. 2x available, depends on version)

Direct voltage:	0...10 V / 2...10 V, max. 17V, overload and short circuit protected	
Permitted load direct voltage:	<ul style="list-style-type: none"> ▪ TVA – 080 / 100 / 120 / 180 R_L ≥ 1250Ω at 10V / R_L ≥ 2000Ω at 10V (at simultaneous output I_{out} with 20mA) ▪ TVA – 200 / 220 R_L ≥ 3333Ω at 10V / R_L ≥ 6666Ω at 10V (at simultaneous output I_{out} with 20mA) 	
Direct current:	0...20mA / 4...20mA, max. 28mA	
Permitted load direct current:	<ul style="list-style-type: none"> ▪ TVA – 080 / 100 / 120 / 180 R_L ≥ 880Ω at 20mA / R_L ≥ 680Ω at 20mA (at simultaneous output U_{out} with 5mA) ▪ TVA – 200 / 220 R_L ≥ 570Ω at 20mA / R_L ≥ 530Ω at 20mA (at simultaneous output U_{out} with 1,5mA) 	
Adjustment range zero value:	-25...+5%	of respective nominal measuring range
Adjustment range end value:	-5...+45%	of respective nominal measuring range
Transmission frequency:	≤ 500 Hz	
Limit value deviation:	≤ 0,2%	of factory calibrated measuring range (delivery setting)
Range changing deviation:	≤ 2% of respective nominal measuring range	
Characteristic deviation:	≤ 0,05% of respective nominal measuring range	
Temperature deviation:	≤ 0,05% / 10 K of respective nominal measuring range	
Long term deviation:	≤ ±0,1% of respective nominal measuring range / year	
Influence output load:	≤ 0,05% of respective nominal measuring range	

Materials

Connection housing:	PA – polyamide
Terminal housing:	PA – polyamide
Sticker:	PE – polyester

Connection terminals

Number:	3 resp. 4 terminal blocks with each 4 terminals, everlasting screws
Connection cross-section:	maximum 1 x 2,5 mm or 2 x 1,5 mm

Housing style

Housing:	Series installation housing, 22,5mm wide
Weight:	100 g

Environmental conditions

Environmental temperature:	Single installation	- 40°C...+70°C	versions TVA – 080 / 100 / 120 / 180
		- 40°C...+60°C	versions TVA – 200 / 220
	Series installation	- 40°C...+60°C	versions TVA – 080 / 100 / 120 / 180
		- 40°C...+50°C	versions TVA – 200 / 220
Climatic classification:	3K3 resp. 3M2	DIN EN 60721-3-3	
Protection classification:	IP20	DIN EN 60529	
EM – compatibility:	emission	DIN EN 61326-1	operation device class B
	immunity	DIN EN 61326-1	industrial range