

Technical manual BA 0110



signal converter

Transcont WTA – 100

Temperature transmitter – passive

for conversion and supervision of a
Pt100 temperature signal

Input signal Pt100 in 2- or 3-wire-technology

- Zero value $-100^{\circ}\text{C} \dots +100^{\circ}\text{C}$
- Measuring range 30K...700K
- 12 standard measuring ranges or adjustment by specification

Output signals

- Direct current 4...20mA
- Direct voltage 0...10V
- 2x PNP switching output

High accuracy

ATEX II (1) G [Ex ia] IIC

Certification for the connection of temperature measuring resistors Pt100 in explosion hazardous areas

ACS-CONTROL-SYSTEM
know how mit system



Lauterbachstr. 57 – 84307 Eggenfelden – Germany
Tel: +49 8721/9668-0 – Fax: +49 8721/9668-30
info@acs-controlsystem.de – www.acs-controlsystem.de

Index

1.	Application	3
2.	Function	3
3.	Safety notes	4
4.	Installation	5
5.	Electrical connection	5
6.	Maintenance	6
7.	Repair	6
8.	Technical data	7
9.	Order code overview	8

1. Application

The passive temperature transmitter **Transcont WTA – 100** is used, to linearize Pt100 temperature signals in the range from -100°C to $+600^{\circ}\text{C}$ with a measuring span between 20 Kelvin and 700 Kelvin and to convert it into an electrical standard signals 4...20mA resp. 0...10V.

In the variants type AS resp. BS, two per potentiometer freely adjustable, overload and short circuit protected PNP switching outputs are integrated. Thus in many applications the use of separate evaluation devices are not necessary.

For the connection of temperature measuring resistors Pt100 in explosion hazardous areas, the device is equipped with a intrinsically safe supply and signal circuit ATEX II (1) G [Ex ia] IIC.

2. Function

Measuring principle

The connected resistance proportional electrical Pt100 voltage signal is measured by the evaluation circuit, linearized, adjusted according to the factory settings and transmitted to the output signal 4...20mA or 0...10V.

Function supervision

The device is equipped with a function supervision.

The voltage signal of the Pt100 is monitored continuously. At wire break resp. wire short circuit a fail information is generated at the 4...20 mA resp. 0...10V output signal.

At wire break the output signal rises up to 21,7 mA resp. 10,85 V, at wire short circuit the output signal falls to 3,55mA resp. 0V.

At a short circuit between terminals 5 and 6 the device will operate in 2-wire-connection.

Signal evaluation – PNP switching outputs

There are two per potentiometer freely adjustable, overload and short circuit protected PNP switching outputs integrated, for which the safety function (minimum resp. maximum safety) can be freely set.

The limit value can be adjusted by a front sided potentiometer according to the output signal using a helping voltage that can be measured at the front sided measurement sleeves. The voltage difference 0,2V at the front sided sleeves equals the output zero signal 4mA resp. 0V and the voltage difference 1,0V at the front sided sleeves equals the output end signal 20mA resp. 10V.

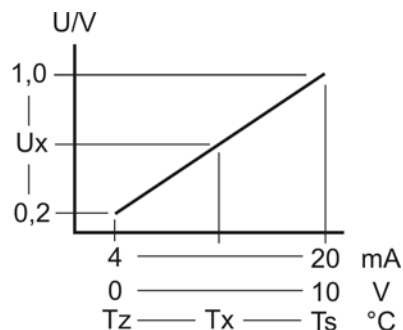

The voltage difference between the front sided sleeves for a needed limit value can be calculated.

$$U_x = 0,2V + \left(\frac{0,8V}{(T_s - T_z)} \times (T_x - T_z) \right)$$

with

U_x = voltage difference to be adjusted at the front sided sleeves

T_x = needed temperature limit value

T_z = factory set temperature zero value (zero)

T_s = factory set temperature end value (Span)

The calculation must be proceeded with correct sign. For $(T_s - T_z)$ this results e.g. at a factory set device setting $-100^{\circ}\text{C} \dots +100^{\circ}\text{C}$ for $T_s = +100^{\circ}\text{C}$ and $T_z = -100^{\circ}\text{C}$ to $+100^{\circ}\text{C} - (-100^{\circ}\text{C}) = 200^{\circ}\text{C}$

The transgression resp. underrun of the set limit value causes the switching of the respective switching output depending on the configured safety function (minimum resp. maximum safety).

Safety function

The safety function defines the operation principle of the output.

- Maximum safety: The output switches off, if the switching level is exceeded or the power supply fails.
- Minimum safety: The output switches off, if the switching level is underrun or the power supply fails.

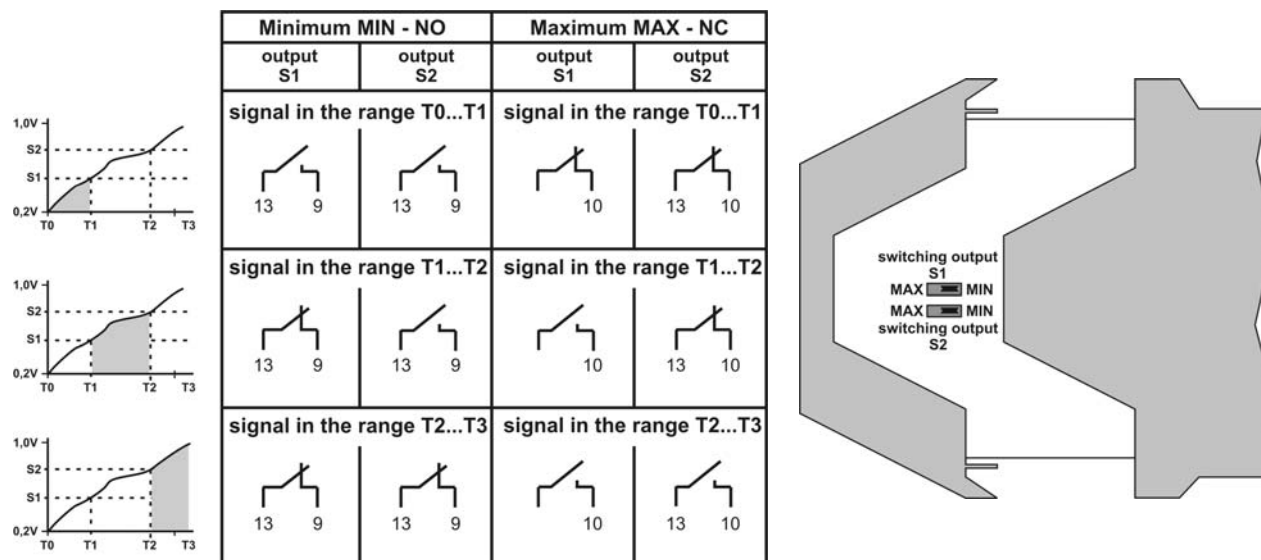

The configuration of the safety function per switching output is carried out by jumper, inside the device.

For configuration release the upper housing part at top and bottom side behind the terminals by using a screwdriver and pull it out of the housing. Drop-in pin's avoid a complete pulling out. Following the respective jumper can be set according to the desired functions to MAX or MIN.

3. Safety notes

Each person that is engaged with inauguration and operation of this device, must have read and understood this technical manual and especially the safety notes.



Installation, electrical connection, inauguration and operation of the device must be made by a qualified employee according to the informations in this technical manual and the relevant standards and rules.

The device may only be used within the permitted operation limits that are listed in this technical manual. Every use besides these limits as agreed can lead to serious dangers.

The device meets the legal requirements of all relevant EC directives. **CE 0158**

Safety notes for electrical operating supplies for explosive hazardous areas

If a device is installed and operated in explosive hazardous areas, the general Ex construction standards (DIN EN 60079-14, VDE0165), this safety notes and the enclosed EC conformity certificate must be observed. The installation of explosive hazardous systems must be carried out principally by specialist staff.

The device meets the classification:

II (1) G [Ex ia] IIC resp. II (2) G [Ex ib] IIC

The device is conceived for measurement of temperatures in explosive hazardous areas, that needs devices of category 1. The measured medium may also be combustible gases, vapors, liquids and dusts.

The permissible maximum values for U_i , I_i and P_i are equal for variants. To this there must be paid especially attention in the case of combining more intrinsically safe circuits at the variant B0 with voltage output 0...10V and at the variants AS und BS with PNP switching outputs. The rules for combination of intrinsically safe circuits must be applied.

The device is a affiliated operating supply and may only be used outside explosion hazardous areas.

4. Installation

The device is conceived for vertical installation on a standard fastening rail acc. to DIN EN 60715 TH 35-7,5 resp. TH35-15.

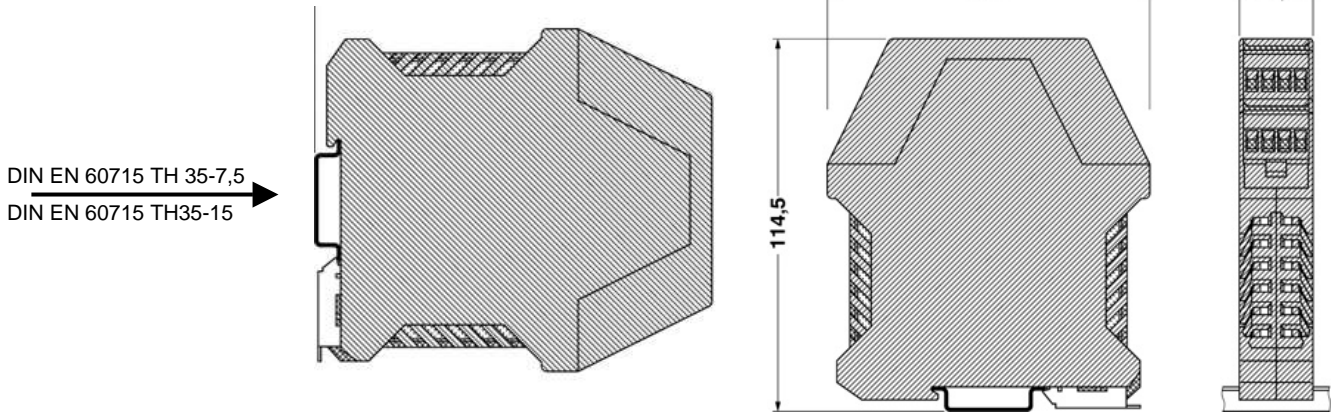

The device must be installed protected against dust and humidity, e.g. in control stations or in a suitable protection housing with a minimum protection classification IP55 acc. to DIN EN 60529.

The devices must be installed weather and stroke protected, ideally at places without direct solar radiation. This is especially important in warm climatic regions.

5. Electrical connection

The electrical connection of the device must be carried out according to the respective country specific standards. Incorrect installation or adjustment could cause applicationally conditioned risks.

For inauguration it is suggested, to deactivate all connected control devices, to avoid unwanted control reactions. Measuring input and signal output resp. both PNP switching outputs are not galvanically isolated from each other.

For the connection cable between the device and the Pt100 resp. connected devices a standard installation cable or multi-wire cable for measuring intends with a maximum of 25 Ω per wire can be used. For the connection use only suitable cables, that fulfills the requirements e.g. regarding temperature, chemical resistance or laying at the place of installation.

The use of a shielded signal cable is recommended, if strong electromagnetic influences could happens, e.g. due to machines or radio equipment. In that case the shielding of the cable should be connected to earth only at the side of the Pt100 resp. of the connected device.

The signal cable should be installed separated from power leading wires.

Connection of the Pt100 – measuring input

The resistance temperature sensor Pt100 is connected to the head transmitter in 2- or 3-wire-connection.

Because the measured Pt100 voltage signal is very small, the resistance of the leads can cause an error source that may not be neglected.

The constant feed current also produces at the resistance of the leads a voltage drop and according to the requirements of the measurement it must be tried to neutralize this measurement error. Using resp. connecting a Pt100 in 3-wire-connection it is possible to completely eliminate the influence of the lead resistance.

If a Pt100 in 2-wire-connection is used, the measuring error, that is generated by the lead resistance, will result in the case of a signal increase.

Connection scheme

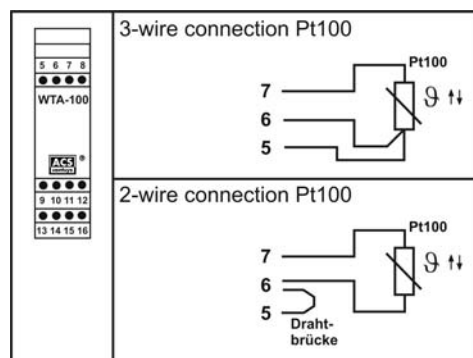

Connection supply voltage / signal output / PNP switching output

The voltage applied to the terminal contacts may not exceed 40 V at the variants A0 / AS resp. 35 V at the variants B0 / BS, to avoid damage of the electronic. All connections are polarity protected.

A load, e.g. the measuring shunt of an evaluation device, in series with a temperature transmitter of the variant A0 / AS with 4...20 mA current signal in 2-wire-technology reduces the supply voltage available at the temperature transmitter.

This results in a maximum value for this resistor, where a correct function is still possible.

The maximum load at signal current 20mA results from:

$$R_L = \frac{(V_s - 8,5V)}{20mA} \quad \text{with } V_s = \text{applying supply voltage.}$$

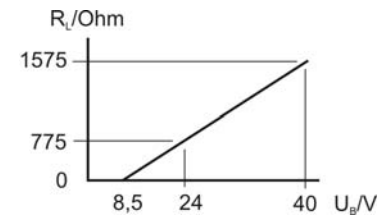

The graph besides shows the characteristics for the resistor values at 24 V and 40 V.

Inductive loads at the pnp switching outputs, e.g. relays or contactors may only be used with a free-wheeling diode or a RC protection circuit to avoid high voltage peaks.

The loads at the PNP switching outputs will be connected to the +terminal of the supply voltage by a semiconductor switch contactless and by this bounce-free. At an activated switching state a positive signal near supply voltage is feed to the outputs.

At deactivated switching state and at failure of supply voltage the semiconductor switch is shut off.

The PNP switching outputs are current limited to 0,2...0,25 A and are overload and short circuit protected.

Connection scheme

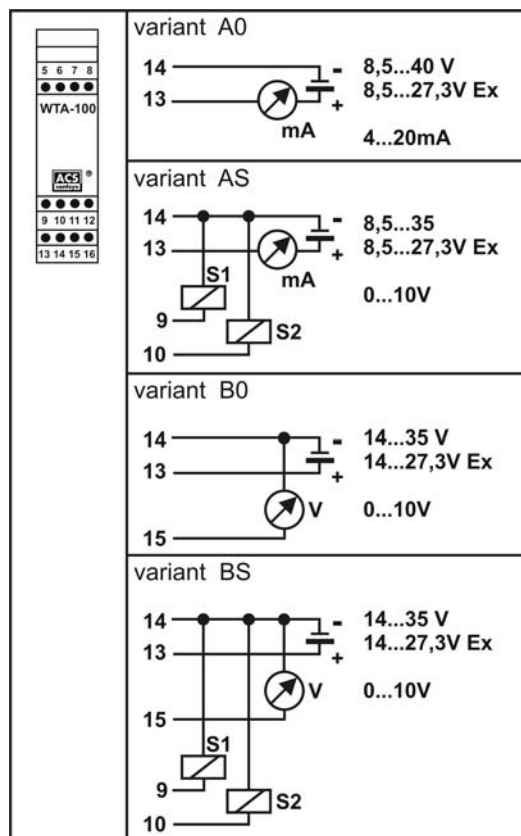

6. Maintenance

The device is free of maintenance.

7. Repair

A repair may only be carried out by the manufacturer. When sending back the device, add a note with the description of the error and the application.

8. Technical data

Auxiliary power supply

Permitted supply voltage:	Reverse polarity protected		
	Variant A0/AS	8,5...40 V DC	Ex 8,5...27,3 V DC
	Variant B0/BS	14...35 V DC	Ex 14...27,3 V DC
Ripple voltage:	≤ 2 V _{PP} condition: within the permitted supply voltage range		
Supply current:	2-wire-technology	4...20 mA ≤ 22 mA	PNP switching outputs no load
	3-wire-technology	0...10 V ≤ 10 mA	PNP switching outputs no load

Signal input

Temperature resistor Pt100:	3- / 2-wire-connection, temperature linear, meas. current 2 x 0,5mA ± 0,2mA
Measuring signal range:	-100°C...+600°C, dependent on settings resp. configuration
Wire resistance:	≤ 40 Ω per wire

Signal output 4...20mA

Direct current:	Linear characteristic from 3,55 mA ... 20,7 mA, 2-wire-technology
Error monitoring input:	Output signal 20,7 mA at wire break Output signal 3,55 mA at short circuit terminals 5/7 resp. 6/7 Measurement in 2-wire-connection at short circuit terminals 5/6
Permitted load:	$R_L \max = (V_S - 8,5) / 20\text{mA}$
Minimum delay time:	≤ 2 ms

Signal output 0...10V

Direct voltage:	Linear characteristic from ≤ 0,01 V ... 10,35 V, 3-wire-technology
Error monitoring input:	Output signal 10,85 V at wire break Output signal ≤ 0,01 V at short circuit terminals 5/7 resp. 6/7 Measurement in 2-wire-connection at short circuit terminals 5/6
Permitted load:	$R_L \geq 2500 \Omega$, equals 4 mA at signal 10 V, current limited
Minimum delay time:	≤ 2 ms

PNP switching outputs

Function ²⁾ :	2x PNP switching to +V _s Function NO/NC configurable by jumper Adjustment 0%...100% by multi-turn potentiometer, hysteresis 1% ± 0,25%	
Output voltage:	$V_{OUT} \geq +V_s - 1,5 V$	
Output current:	≤ 250 mA, min. 200 mA	current limited, short circuit protected
Rise up time:	≤ 700 μs	output load ≤ 3000 Ω resp. ≥ 4,5 mA
Delay time:	≤ 2 ms	
Switching cycles:	≥ 100.000.000	

Measuring accuracy

Accuracy ^{2) 8) 12)} :	≤ 0,2K or 0,1%	higher value is valid
Characteristic deviation ^{3) 5) 8) 12)} :	≤ 0,1%	
Temperature deviation ^{2) 8) 12)} :	≤ 0,05% / 10K	
Long term drift ^{2) 8) 12)} :	≤ ±0,1 K / year or 0,05% / year	higher value is valid
Influence of output load ¹³⁾ :	≤ 0,02% / 100Ω	
Influence of supply voltage ^{8) 12) 13)} :	≤ 0,02% / 10V	

²⁾ Referring to nominal measuring span resp. full scale (FS)
³⁾ Nonlinearity + Hysteresis + Reproducibility
⁵⁾ At limit value adjustment
⁸⁾ At reference conditions
¹²⁾ Higher values for special measuring range
¹³⁾ Of the nominal output signal span 16mA/10V

Materials

Connection housing:	PA – polyamide
Terminal housing:	PA – polyamide
Sticker:	PE – polyester

Connection terminals

Number:	2 resp. 3 terminal blocks with each 4 terminals, everlasting screws
Connection cross-section:	maximum 1 x 2,5 mm or 2 x 1,5 mm

Housing style

Housing:	Series installation housing, 22,5mm wide
Weight:	100 g

Environmental conditions

Environmental temperature:	– 40°C...+85°C		
Climatic classification:	3K3 resp. 3M2	DIN EN 60721-3-3	
Moisture condensation:	Allowable		
Protection classification:	IP20	DIN EN 60529	
EM – compatibility:	Emission	DIN EN 61326-1	operation device class B
	Immunity	DIN EN 61326-1	industrial range
Reference conditions:	DIN EN 60770-1		
	T = 25 °C, relative humidity 45...75 %, Environmental air pressure 860...1060 kPa		

9. Order code overview

Type:

WTA-100 Standard
Ex WTA-100 ATEX II (1) G [Ex ia] IIC

Temperature range:

A Range	0°C to +50,0°C	H Range	0°C to +400,0°C	
B Range	0°C to +100,0°C	J Range	0°C to +500,0°C	
C Range	0°C to +150,0°C	L Range	0°C to +600,0°C	
E Range	0°C to +200,0°C	Q Range	-40°C to +60,0°C	
F Range	0°C to +250,0°C	O Range	-50°C to +100,0°C	
G Range	0°C to +300,0°C	N Range	-100°C to +50,0°C	
		Y	special measuring range	separate spec. necessary

Transmitter electronic:

A0	4...20 mA	2-wire-technology	
AS	4...20 mA	2-wire-technology	with 2x PNP switching output
B0	0...10 V	3-wire-technology	
BS	0...10 V	3-wire-technology	with 2x PNP switching output

— — — — GO