

Operating Instructions

ExTVA-600-U0

Active barrier, 1-channel for 4 to 20 mA,
HART® transparent, supply 24 to 230 V_{AC/DC},
input and output active/passive, Ex-certification

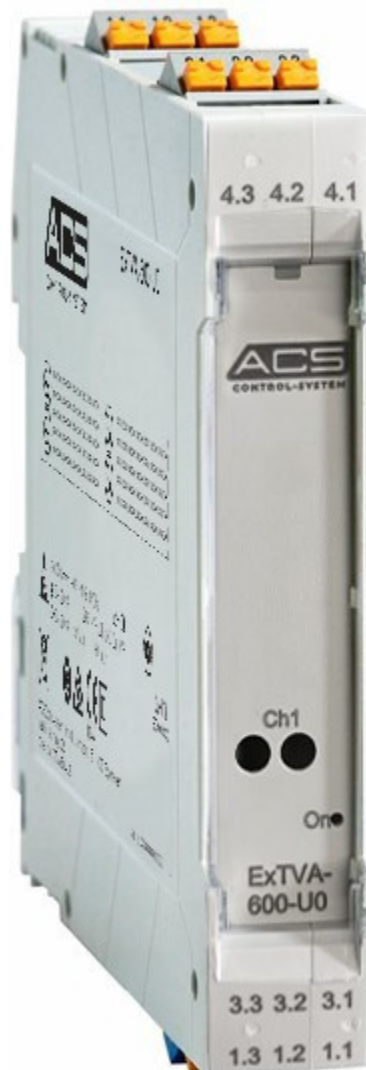

Table of contents

1	About this document	3	11	Repair	14
1.1	Symbols.....	3	11.1	General information.....	14
1.2	Documentation.....	4	11.2	Spare parts	14
1.3	Registered trademarks	4	11.3	Return	14
2	Basic safety instructions.....	5	11.4	Disposal.....	15
2.1	Requirements for the personnel	5	12	Technical data	16
2.2	Intended use.....	5	12.1	Function and system design	16
2.3	Workplace safety.....	5	12.2	Input.....	16
2.4	Operational safety	5	12.3	Output.....	16
2.5	Product safety.....	6	12.4	Power supply.....	17
2.6	Installation instructions.....	6	12.5	Performance characteristics.....	19
3	Product descriptions.....	6	12.6	Mounting.....	19
3.1	Product description	6	12.7	Environment.....	20
4	Incoming acceptance and product identification	7	12.8	Mechanical construction.....	21
4.1	Incoming acceptance.....	7	12.9	Display and operating elements.....	22
4.2	Product identification	7	12.10	Ordering information	22
4.3	Storage and transport	8	12.11	Accessories	22
5	Mounting	8	12.12	Certificates and approvals.....	23
5.1	Mounting requirements	8	12.13	Supplementary documentation	23
5.2	Installing a DIN rail device.....	8	13	Appendix: system overview	24
5.3	Disassembling the DIN rail device	9	13.1	Power supply	24
6	Electrical connection.....	9	13.2	Applications of the isolating amplifiers	24
6.1	Connecting requirements.....	9			
6.2	Special connection instructions	10			
6.3	Quick wiring guide.....	11			
6.4	Connecting the supply voltage.....	11			
6.5	Post-connection check.....	12			
7	Operation options	12			
7.1	Display and operating elements.....	12			
8	Commissioning.....	13			
8.1	Post-installation check	13			
8.2	Switching on the device	13			
9	Diagnostics and troubleshooting.....	13			
9.1	General troubleshooting.....	13			
10	Maintenance and cleaning.....	14			
10.1	Cleaning of surfaces not in contact with the medium.....	14			

1 About this document

1.1 Symbols

1.1.1 Safety symbols

DANGER

This symbol alerts you to a dangerous situation. Failure to avoid this situation will result in serious or fatal injury.

WARNING

This symbol alerts you to a potentially dangerous situation. Failure to avoid this situation can result in serious or fatal injury.













CAUTION

This symbol alerts you to a potentially dangerous situation. Failure to avoid this situation can result in minor or medium injury.



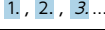

NOTICE

This symbol alerts you to a potentially harmful situation. Failure to avoid this situation can result in damage to the product or something in its vicinity.

1.1.2 Symbols for certain types of information

Symbol	Meaning
	Permitted Procedures, processes or actions that are permitted.
	Preferred Procedures, processes or actions that are preferred.
	Forbidden Procedures, processes or actions that are forbidden.
	Tip Indicates additional information.
	Reference to documentation
	Reference to page
	Reference to graphic
	Notice or individual step to be observed
	Series of steps
	Result of a step
	Help in the event of a problem
	Visual inspection



1.1.3 Electrical symbols

	Direct current		Alternating current
	Direct current and alternating current		Ground connection A grounded terminal which, as far as the operator is concerned, is grounded via a grounding system.

1.1.4 Symbols in graphics

1, 2, 3,...	Item numbers	A, B, C, ...	Views
-------------	--------------	--------------	-------

1.1.5 Symbols at the device

	Warning Observe the safety instructions contained in the associated Operating Instructions
	Equipment protected throughout by DOUBLE INSULATION or REINFORCED INSULATION

1.2 Documentation

The following document types are available in the Downloads area of the ACS website (www.acs-controlsystem.com), depending on the device version:

Document type	Purpose and content of the document
Brief Operating Instructions (KA)	Guide that takes you quickly to the 1st measured value The Brief Operating Instructions contain all the essential information from incoming acceptance to initial commissioning.
Operating Instructions (BA)	Your reference document The Operating Instructions contain all the information that is required in various phases of the life cycle of the device: from product identification, incoming acceptance and storage, to mounting, connection, operation and commissioning through to troubleshooting, maintenance and disposal.
Safety instructions (XA)	Depending on the approval, safety instructions for electrical equipment in hazardous areas are also supplied with the device. These are an integral part of the Operating Instructions. The nameplate indicates which Safety Instructions (XA) apply to the device.

1.3 Registered trademarks

HART®

Registered trademark of the FieldComm Group, Austin, Texas, USA

2 Basic safety instructions

2.1 Requirements for the personnel

The personnel for installation, commissioning, diagnostics and maintenance must fulfill the following requirements:

- ▶ Trained, qualified specialists must have a relevant qualification for this specific function and task.
- ▶ Are authorized by the plant owner/operator.
- ▶ Are familiar with federal/national regulations.
- ▶ Before starting work, read and understand the instructions in the manual and supplementary documentation as well as the certificates (depending on the application).
- ▶ Follow instructions and comply with basic conditions.

The operating personnel must fulfill the following requirements:

- ▶ Are instructed and authorized according to the requirements of the task by the facility's owner-operator.
- ▶ Follow the instructions in this manual.

2.2 Intended use

The active barrier is used for the safe isolation of 0/4 to 20 mA standard signal circuits. An intrinsically safe version is optionally available for operation in Zone 2. The device is designed for installation on DIN rails in accordance with IEC 60715.

Product liability: The manufacturer does not accept any responsibility for damage that results from non-designated use and from failure to comply with the instructions in this manual.

2.3 Workplace safety

When working on and with the device:

- ▶ Wear the required personal protective equipment as per national regulations.

2.4 Operational safety

Risk of injury!

- ▶ Operate the device only if it is in proper technical condition, free from errors and faults.
- ▶ The operator is responsible for interference-free operation of the device.

Modifications to the device

Unauthorized modifications to the device are not permitted and can lead to unforeseeable dangers:

- ▶ If modifications are nevertheless required, consult with the manufacturer.

Repair

To ensure continued operational safety and reliability:

- ▶ Carry out repairs on the device only if they are expressly permitted.
- ▶ Observe federal/national regulations pertaining to the repair of an electrical device.
- ▶ Use only original spare parts and accessories from the manufacturer.

Hazardous area

To eliminate danger to persons or the facility when the device is used in the hazardous area (e.g. explosion protection):

- Check the nameplate to verify if the device ordered can be put to its intended use in the hazardous area.
- Observe the specifications in the separate supplementary documentation that is an integral part of these instructions.

2.5 Product safety

This device is designed in accordance with good engineering practice to meet state-of-the-art safety requirements, has been tested, and left the factory in a condition in which it is safe to operate.

2.6 Installation instructions

- The device's IP20 degree of protection is intended for a clean and dry environment.
- Do not expose the device to mechanical and/or thermal stress that exceeds the specified limits.
- The device is intended for installation in a cabinet or similar housing. The device may only be operated as an installed device.
- To protect against mechanical or electrical damage, the device must be installed in an appropriate housing with a suitable degree of protection according to IEC/EN 60529.
- The device fulfills the EMC regulations for the industrial sector.

3 Product descriptions

3.1 Product description

3.1.1 Product design

Active barrier, 1-channel

- The active barrier is used for the transmission and galvanic isolation of 0/4 to 20 mA/ HART signals. The device has an active/passive current input to which a 2- or 4-wire transmitter can be directly connected. The output of the device can be operated actively or passively. The current signal is then available to the PLC / controller or to other instrumentation at plug-in screw terminals or optional push-in terminals.
- HART communication signals are transmitted bidirectionally by the device. Connection sockets for connecting HART communicators are integrated into the front of the device.
- The device is optionally available as an "associated apparatus", which allows devices to be connected in Ex Zone 0/20 [ia] and operated in Ex Zone 2 [ec]. 2-wire transmitters are supplied with power, and transmit analog 0/4 to 20 mA/HART measured values from the hazardous area to the non-hazardous area. These devices are accompanied by separate Ex documentation, which is an integral part of this manual. Compliance with the installation instructions and connection data in this documentation is mandatory!

4 Incoming acceptance and product identification

4.1 Incoming acceptance

On receipt of the delivery:

1. Check the packaging for damage.
Report all damage immediately to the manufacturer.
Do not install damaged components.
2. Check the scope of delivery using the delivery note.
3. Compare the data on the nameplate with the order specifications on the delivery note.
4. Check the technical documentation and all other necessary documents, e.g. certificates, to ensure they are complete.

 If one of the conditions is not satisfied, contact the manufacturer.

4.2 Product identification

The device can be identified in the following ways:

- Nameplate specifications

4.2.1 Nameplate

Do you have the correct device?

The nameplate provides you with the following information on the device:

- Manufacturer identification, device designation
 - Order code
 - Extended order code
 - Serial number
 - Tag name (TAG) (optional)
 - Technical values, e.g. supply voltage, current consumption, ambient temperature, communication-specific data (optional)
 - Degree of protection
 - Approvals with symbols
 - Reference to Safety Instructions (XA) (optional)
- Compare the information on the nameplate with the order.

4.2.2 Name and address of manufacturer

Name of manufacturer:	ACS Control-System GmbH
Address of manufacturer:	Lauterbachstrasse 57, 84307 Eggenfelden www.acs-controlsystem.com

4.3 Storage and transport

Storage temperature: -40 to +80 °C (-40 to +176 °F)

Maximum relative humidity: < 95%

 Pack the device for storage and transportation in such a way that it is reliably protected against impact and external influences. The original packaging provides the best protection.

Avoid the following environmental influences during storage:

- Direct sunlight
- Proximity to hot objects
- Mechanical vibration
- Aggressive media

5 Mounting

5.1 Mounting requirements

5.1.1 Dimensions

 For information on device dimensions, see the "Technical data" section.

5.1.2 Mounting location

The device is designed for installation on 35 mm (1.38 in) DIN rails in accordance with IEC 60715 (TH35).

NOTICE

- When using in hazardous areas, the limit values of the certificates and approvals must be observed.

 For information on ambient conditions, see the "Technical data" section.

5.2 Installing a DIN rail device

The device can be installed in any position (horizontal or vertical) on the DIN rail without lateral clearance from neighboring devices. No tools are required for installation. The use of end brackets (type WEW "35/1" or similar) on the DIN rail is recommended as an end support for the device.

 When installing several devices side by side, it is important to ensure that the maximum side wall temperature of 80 °C (176 °F) of the individual devices is not exceeded. If this cannot be guaranteed, mount the devices at a distance from one another or ensure sufficient cooling.

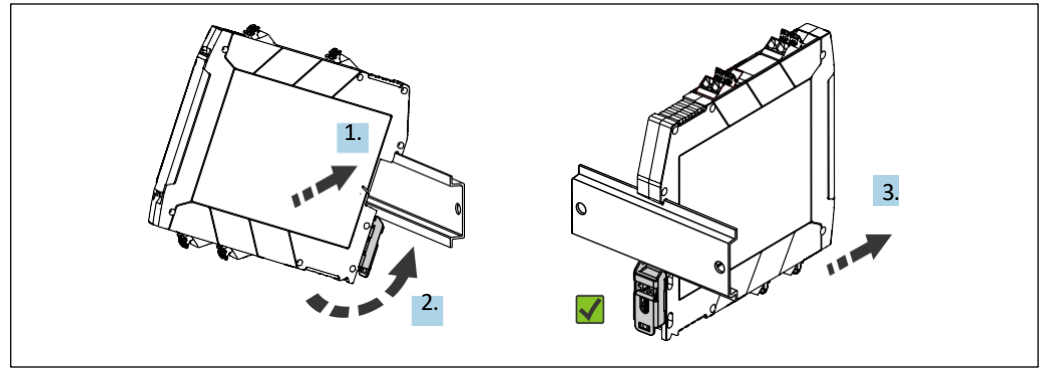

1 Installing on DIN rail

1. Position the top DIN rail groove at the top end of the DIN rail.
2. While holding the front of the device horizontally, lower it until you hear the locking clip of the device click into place on the DIN rail.
3. Pull gently on the device to check if it is correctly mounted on the DIN rail.

5.3 Disassembling the DIN rail device

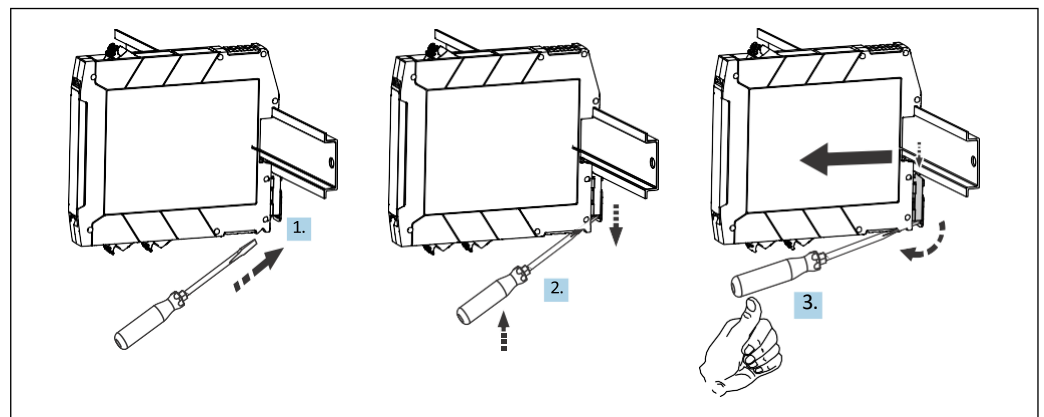

2 Disassembling the DIN rail device

1. Insert a screwdriver into the tab of the DIN rail clip.
2. Use the screwdriver to pull down on the DIN rail clip as shown in the diagram.
3. Hold down the screwdriver to remove the device from the DIN rail.

6 Electrical connection

6.1 Connecting requirements

A flat-blade screwdriver is required to establish an electrical connection to screw or push-in terminals.

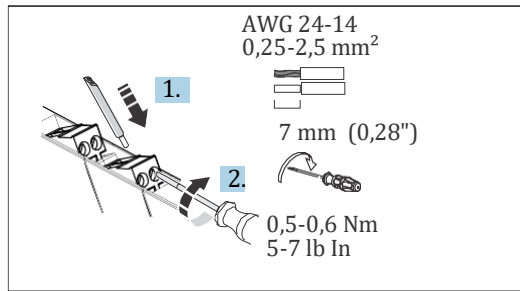

3 Electrical connection

CAUTION

Destruction of parts of the electronics

- Switch off the power supply before installing and connecting the device.

NOTICE

Destruction or malfunction of parts of the electronics

- ⚠ ESD - electrostatic discharge. Protect the terminals and HART sockets on the front from electrostatic discharge.
- A shielded cable is recommended for HART communication. Observe grounding concept of the plant.

i For information on the connection data, see the "Technical data" section.

i Only use copper cables with a minimum temperature rating of 75 °C (167 °F) as the connecting cables.

6.2 Special connection instructions

- Disconnecting devices and auxiliary circuit protective systems with suitable AC or DC values must be provided within reach in the building installation.
- A switch/power circuit breaker must be provided close to the device and clearly marked as a disconnecting unit for this device.
- A circuit breaker (nominal current ≤ 10 A; break capacity 6 kA; e.g. type B) must be available within reach for the supply line.

i For information on the connection data, see the "Technical data" section.

6.3 Quick wiring guide

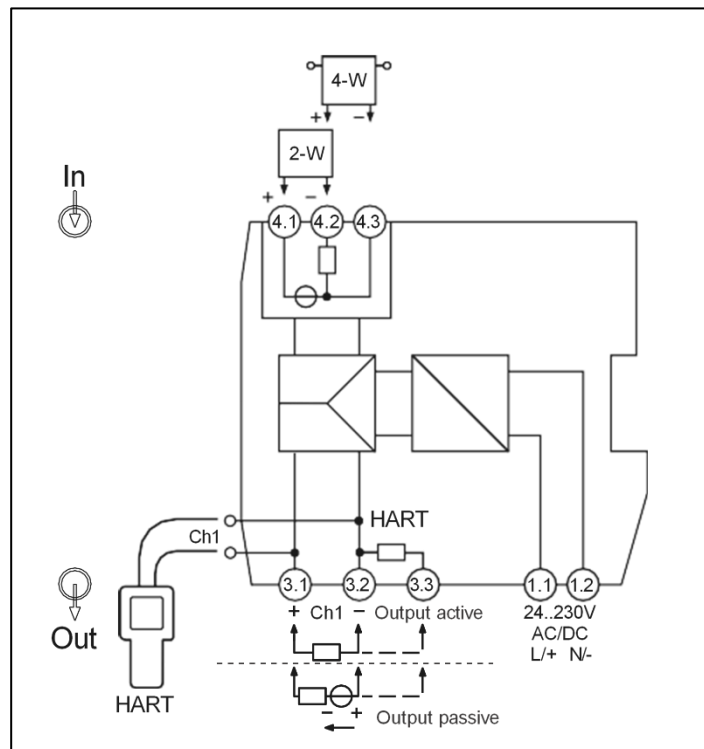

4 Terminal assignment

Connection for operation with active output:

1. Connect + to 3.1.
 2. Connect - to 3.2.
- Switching of the mode of operation occurs automatically.

Connection for operation with passive output:

1. Connect + to 3.2.
 2. Connect - to 3.1.
- Switching of the mode of operation occurs automatically.

- i** HART communicators can be connected to the HART connection sockets. Ensure that there is an adequate external load ($\geq 230 \Omega$) in the output circuit. If the external load is not sufficient, an internal 250Ω communication resistor can be added to the measuring loop via the alternative terminal assignment (terminal 3.3.) to use the HART connection sockets.

6.4 Connecting the supply voltage

The power is supplied via terminals 1.1 and 1.2.

6.5 Post-connection check

Device condition and specifications	Notes
Are the device or cables free from damage (visual check)?	--
Do the ambient conditions match the device specification (e.g. ambient temperature, measuring range, etc.)?	See 'Technical data'.
Electrical connection	Notes
Does the supply voltage match the information on the nameplate?	Active barrier: U = 24 to 230 V
Are the power supply and signal cables connected correctly?	--
Are all the screw terminals well tightened and have the connections of the push-in terminals been checked?	--

7 Operation options

7.1 Display and operating elements

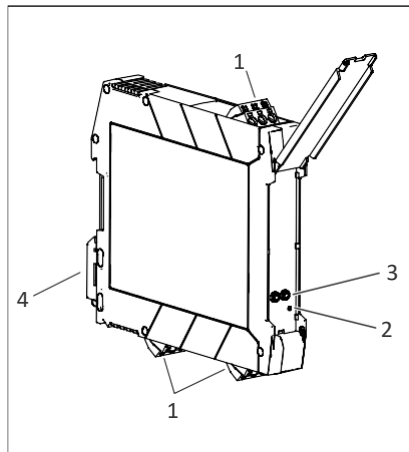

A0045155

5 Display and operating elements

- 1 Plug-in screw terminal
- 2 Green LED "On", power supply
- 3 Connection sockets for HART communication (channel 1)
- 4 DIN rail clip for DIN rail mounting

7.1.1 Local operation

Hardware settings / configuration

No manual hardware settings are required at the device for commissioning.

Attention must be paid to the different terminal assignment when connecting 2/4-wire transmitters. At the output side, the connected system is detected and automatic switching takes place between the active and passive mode.

8 Commissioning

8.1 Post-installation check

Before commissioning the device, ensure that all post-mounting and post-connection checks have been carried out.

NOTICE

- Before commissioning the device, make sure that the supply voltage matches the voltage specifications on the nameplate. Failure to perform these checks may result in damage to the device caused by the incorrect supply voltage.

8.2 Switching on the device

Switch on the supply voltage. The green LED display on the front of the device indicates that the device is operational.

-  To prevent incorrect wiring, the output current should be verified when simulating a high alarm at the input.

9 Diagnostics and troubleshooting

9.1 General troubleshooting

Always start troubleshooting with the checklists below if faults occur after startup or during operation. The checklists take you directly (via various queries) to the cause of the problem and the appropriate remedial measures.

-  Due to its design, the device cannot be repaired. However, it is possible to send the device in for examination. See the "Return" section.

General faults

Fault	Possible cause	Remedial action
Device does not respond.	Supply voltage does not match the voltage specified on the nameplate.	Check the voltage directly using a voltmeter and correct.
	Connecting cables are not in contact with the terminals.	Ensure electrical contact between the cable and the terminal.
	Electronics module is defective.	Replace the device.
HART communication is not working.	Missing or incorrectly installed communication resistor.	Install the communication resistor (230 Ω) correctly.
	HART modem is not properly connected.	Connect HART modem correctly.
	HART modem is not set to "HART".	Set HART modem selector switch to "HART".
The power LED on the DIN rail device is not lit (green).	Power failure or insufficient supply voltage.	Check the supply voltage and check if wiring is correct.
High-alarm at the input cannot be output at the output.	Output load is too high (max. output load active / passive: see technical data)	Reduce output load.
	Passive mode: external voltage at the output is incorrectly connected.	Connect external voltage correctly to output.

10 Maintenance and cleaning

No special maintenance work is required for the device.

10.1 Cleaning of surfaces not in contact with the medium

- Recommendation: Use a lint-free cloth that is either dry or slightly dampened using water.
- Do not use any sharp objects or aggressive cleaning agents that corrode the surfaces (displays, housing, for example) and seals.
- Do not use high-pressure steam.
- Observe the degree of protection of the device.

 The cleaning agent used must be compatible with the materials of the device configuration. Do not use cleaning agents with concentrated mineral acids, bases or organic solvents.

11 Repair

11.1 General information

Due to the device's design and construction, it cannot be repaired.

11.2 Spare parts

For spare parts currently available for the product, see online at:
www.acs-controlsystem.com

11.3 Return

The requirements for safe device return can vary depending on the device type and national legislation.

1. If returning the device, pack the device in such a way that it is reliably protected against impact and external influences. The original packaging offers the best protection.

11.4 Disposal



If required by the Directive 2012/19/EU on waste electrical and electronic equipment (WEEE), the product is marked with the depicted symbol in order to minimize the disposal of WEEE as unsorted municipal waste. Do not dispose of products bearing this marking as unsorted municipal waste. Instead, return them to the manufacturer for disposal under the applicable conditions.

12 Technical data

12.1 Function and system design

Product description	<p>Product design</p> <p><i>Active barrier, 1-channel</i></p> <ul style="list-style-type: none"> • The active barrier is used for the transmission and galvanic isolation of 0/4 to 20 mA/ HART signals. The device has an active/passive current input to which a 2- or 4-wire transmitter can be directly connected. The output of the device can be operated actively or passively. The current signal is then available to the PLC / controller or to other instrumentation at plug-in screw terminals. • HART communication signals are transmitted bidirectionally by the device. Connection sockets for connecting HART communicators are integrated into the front of the device. • The device is optionally available as an "associated apparatus", which allows devices to be connected in Ex Zone 0/20 [ia] and operated in Ex Zone 2 [ec]. 2-wire transmitters are supplied with power, and transmit analog 0/4 to 20 mA/HART measured values from the hazardous area to the non-hazardous area. These devices are accompanied by separate Ex documentation, which is an integral part of this manual. Compliance with the installation instructions and connection data in this documentation is mandatory!
---------------------	---

Dependability	We only provide a warranty if the device is installed and used as described in the Operating Instructions.
---------------	--

12.2 Input

Version	The following versions are available: 1-channel
---------	---

Input data, measuring range	<table border="1"> <tr> <td>Input signal range (underrange / overrange)</td> <td>0 to 22 mA</td> </tr> <tr> <td>Function range, input signal</td> <td>0/4 to 20 mA</td> </tr> <tr> <td>Input voltage drop signal for 4-wire connection</td> <td>< 7 V at 20 mA</td> </tr> <tr> <td>Transmitter supply voltage</td> <td>17.5 V ± 1 V at 20 mA Open-circuit voltage: 24.5 V ± 5 %</td> </tr> </table>	Input signal range (underrange / overrange)	0 to 22 mA	Function range, input signal	0/4 to 20 mA	Input voltage drop signal for 4-wire connection	< 7 V at 20 mA	Transmitter supply voltage	17.5 V ± 1 V at 20 mA Open-circuit voltage: 24.5 V ± 5 %
Input signal range (underrange / overrange)	0 to 22 mA								
Function range, input signal	0/4 to 20 mA								
Input voltage drop signal for 4-wire connection	< 7 V at 20 mA								
Transmitter supply voltage	17.5 V ± 1 V at 20 mA Open-circuit voltage: 24.5 V ± 5 %								

12.3 Output

Output data	<table border="1"> <tr> <td>Output signal range (underrange / overrange)</td> <td>0 to 22 mA</td> </tr> <tr> <td>Function range, output signal</td> <td>0/4 to 20 mA</td> </tr> <tr> <td>Transmission behavior</td> <td>1:1 to input signal</td> </tr> <tr> <td>NAMUR NE 43</td> <td>A current at the input that is valid according to NAMUR NE 43 is transmitted to the output (within the specified measuring uncertainty range)</td> </tr> <tr> <td>Maximum load, active mode</td> <td>≤ 500 Ω</td> </tr> <tr> <td>Open-circuit voltage, active mode</td> <td>17.5 V (± 5%)</td> </tr> <tr> <td>Maximum load, passive mode</td> <td>$R_{max} = (U_{ext} - 4 V) / 0.022 A$</td> </tr> </table>	Output signal range (underrange / overrange)	0 to 22 mA	Function range, output signal	0/4 to 20 mA	Transmission behavior	1:1 to input signal	NAMUR NE 43	A current at the input that is valid according to NAMUR NE 43 is transmitted to the output (within the specified measuring uncertainty range)	Maximum load, active mode	≤ 500 Ω	Open-circuit voltage, active mode	17.5 V (± 5%)	Maximum load, passive mode	$R_{max} = (U_{ext} - 4 V) / 0.022 A$
Output signal range (underrange / overrange)	0 to 22 mA														
Function range, output signal	0/4 to 20 mA														
Transmission behavior	1:1 to input signal														
NAMUR NE 43	A current at the input that is valid according to NAMUR NE 43 is transmitted to the output (within the specified measuring uncertainty range)														
Maximum load, active mode	≤ 500 Ω														
Open-circuit voltage, active mode	17.5 V (± 5%)														
Maximum load, passive mode	$R_{max} = (U_{ext} - 4 V) / 0.022 A$														

External voltage, passive mode	U _{ext} = 12 to 30 V
Transmissible communication protocols	HART

Signal on alarm	Line break in input	Input 0 mA / output 0 mA
	Line short circuit in input	Input > 22 mA/ output > 22 mA

Ex connection data See associated XA Safety Instructions

Galvanic isolation	Power supply for input/output	Testing voltage: 3 000 V _{AC} 50 Hz, 1 min
	Input to output	Testing voltage: 1 500 V _{AC} 50 Hz, 1 min

12.4 Power supply

Terminal assignment Quick wiring guide

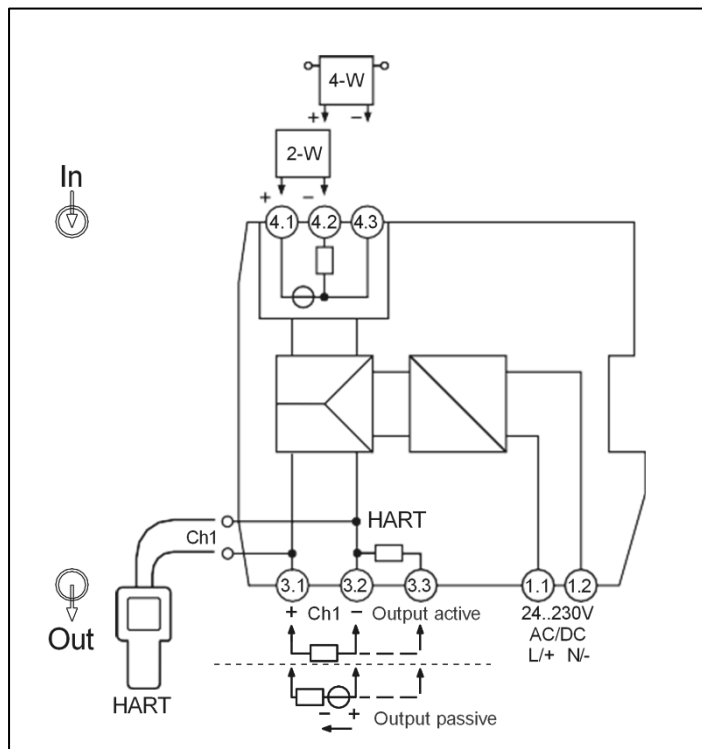

6 Terminal assignment

Connection for operation with active output:

1. Connect + to 3.1.
 2. Connect - to 3.2.
- Switching of the mode of operation occurs automatically.

Connection for operation with passive output:

1. Connect + to 3.2.
 2. Connect - to 3.1.
- Switching of the mode of operation occurs automatically.

i HART communicators can be connected to the HART connection sockets. Ensure that there is an adequate external load ($\geq 230 \Omega$) in the output circuit. If the external load is not sufficient, an internal 250Ω communication resistor can be added to the measuring loop via the alternative terminal assignment (terminal 3.3.) to use the HART connection sockets.

Connecting the supply voltage

The power is supplied via terminals 1.1 and 1.2.

Special connection instructions

- Disconnecting units and auxiliary circuit protective systems with suitable AC or DC values must be provided in the building installation.
- A switch/power circuit breaker must be provided close to the device and clearly marked as a disconnecting unit for this device.
- An overcurrent protection unit ($I \leq 10 \text{ A}$) must be provided in the installation. For information on the connection data, see the "Technical data" section.

Performance characteristics *Power supply*¹⁾

Supply voltage	24 to 230 V _{AC/DC} (-20% / +10%, 0/50/60 Hz)
Power consumption	$\leq 4.9 \text{ VA} / 2.4 \text{ W}$ (20 mA); $\leq 5 \text{ VA} / 2.5 \text{ W}$ (22 mA)
Power loss	$\leq 2 \text{ W}$ (20 mA); $\leq 2.1 \text{ W}$ (22 mA)
Current consumption at 24 V _{DC}	$\leq 0.1 \text{ A}$ (20 mA); $\leq 0.1 \text{ A}$ (22 mA)
Current consumption at 230 V _{AC}	$\leq 0.02 \text{ A}$ (20 mA); $\leq 0.02 \text{ A}$ (22 mA)

1) The data apply for the following operating scenario: input active / output active / output load 0 Ω . When external voltages are connected to the output, the power loss in the device may increase. The power loss in the device can be reduced by connecting an external output load.

Terminals

A flat-blade screwdriver is required to establish an electrical connection to screw terminals.

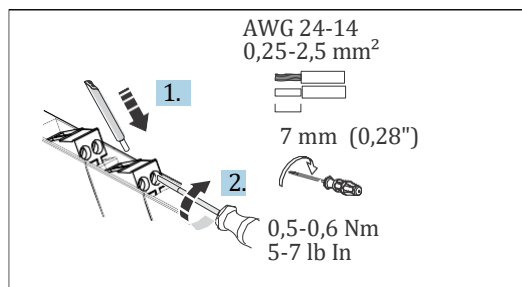

7 *Electrical connection via screw terminals*

Terminal design	Cable design	Cable cross-section
Screw terminals Tightening torque: minimum 0.5 Nm/maximum 0.6 Nm	Rigid or flexible (Stripping length = 7 mm (0.28 in))	0.2 to 2.5 mm ² (24 to 14 AWG)
	Flexible with wire end ferrules (with or without plastic ferrule)	0.25 to 2.5 mm ² (24 to 14 AWG)

Cable specification A shielded cable is recommended for HART communication. Observe grounding concept of the plant.

12.5 Performance characteristics

Response time	Step response (10 to 90 %)	≤ 1 ms
---------------	----------------------------	--------

Reference conditions

- Calibration temperature: +25 °C ±3 K (77 °F ±5.4 °F)
- Supply voltage: 230 V_{AC}
- Output load: 225 Ω
- External output voltage (passive output): 20 V_{DC}
- Warm-up: > 1 h

Maximum measured error *Accuracies*

Transmission error	< 0.1 % / of full scale value (<20 μA)
Temperature coefficient	< 0.01 % /K

Long-term drift Max. ±0.1 %/year (of full scale value)

12.6 Mounting

Mounting location The device is designed for installation on 35 mm (1.38 in) DIN rails in accordance with IEC 60715 (TH35).

NOTICE

- ▶ When using in hazardous areas, the limit values of the certificates and approvals must be observed.



For information on ambient conditions, see the "Technical data" section.

Installing a DIN rail device The device can be installed in any position (horizontal or vertical) on the DIN rail without lateral clearance from neighboring devices. No tools are required for installation. The use of end brackets (type WEW "35/1" or similar) on the DIN rail is recommended as an end support for the device.

i When installing several devices side by side, it is important to ensure that the maximum side wall temperature of 80 °C (176 °F) of the individual devices is not exceeded. If this cannot be guaranteed, mount the devices at a distance from one another or ensure sufficient cooling.

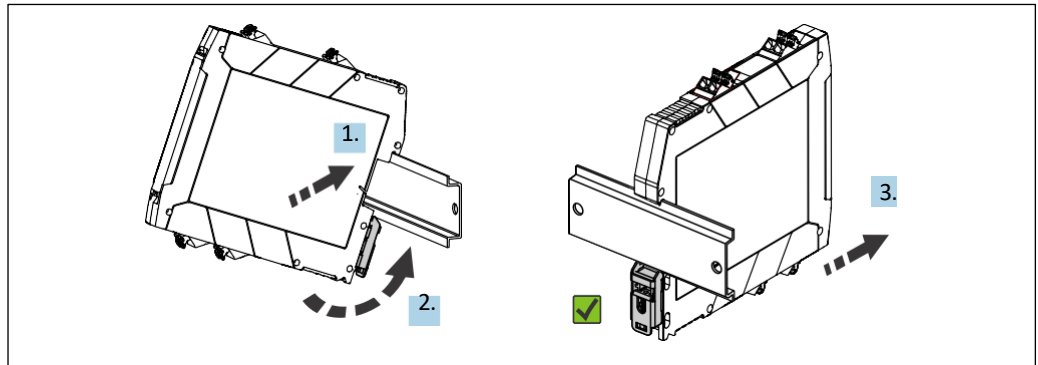

8 Installing on DIN rail

A0041736

1. Position the top DIN rail groove at the top end of the DIN rail.
2. While holding the front of the device horizontally, lower it until you hear the locking clip of the device click into place on the DIN rail.
3. Pull gently on the device to check if it is correctly mounted on the DIN rail.

12.7 Environment

Important ambient conditions	Ambient temperature range	-40 to 60 °C (-40 to 140 °F)	Storage temperature	-40 to 80 °C (-40 to 176 °F)
	Degree of protection	IP 20	Overvoltage category	II
	Pollution degree	2	Humidity	5 to 95 %
	Operating altitude, hazardous area version	≤ 2 000 m (6 562 ft)	Operating altitude, non-hazardous area version	≤ 4 000 m (13 123 ft)
			Insulation class	Class II

Maximum temperature change rate: 0.5 °C/min, no condensation permitted

Shock and vibration resistance: Sinusoidal vibrations, in accordance with IEC 60068-2-6

- 5 to 13.2 Hz: 1 mm peak
- 13.2 to 100 Hz: 0.7g peak

Electromagnetic compatibility (EMC): CE compliance

Electromagnetic compatibility in accordance with all the relevant requirements of the IEC/EN 61326 series and NAMUR Recommendation EMC (NE21). For details, refer to the Declaration of Conformity.

- Maximum measured error < 1% of full scale value
- Strong, pulse-like EMC interference can result in transient (< 1 s) deviations in the output signal ($\geq \pm 1\%$)
- Interference immunity as per IEC/EN 61326 series, industrial requirements
- Interference emission according to IEC/EN 61326 series (CISPR 11) Group 1 Class A

i This unit is not intended for use in residential environments and cannot guarantee adequate protection of the radio reception in such environments.

12.8 Mechanical construction

Design, dimensions

Dimensions in mm (in)

Terminal housing for mounting on DIN rail

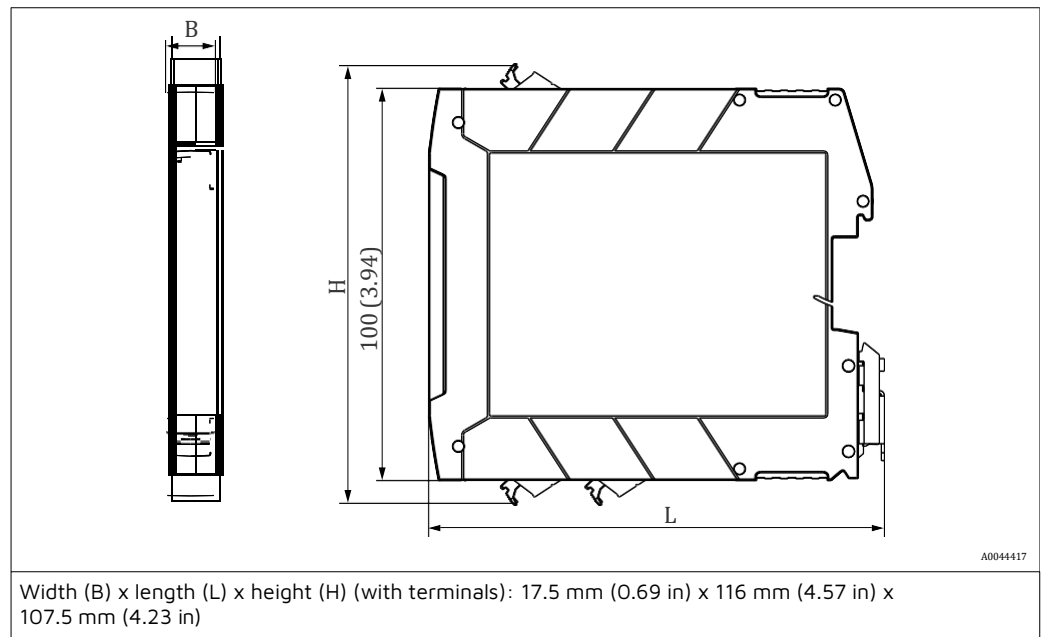

Weight

Device with terminals (values rounded up): Approx. 135 g (4.76 oz)

Color

Light gray

Materials

All the materials used are RoHS-compliant.

Housing: polycarbonate (PC); flammability rating according to UL94: V-0

12.9 Display and operating elements

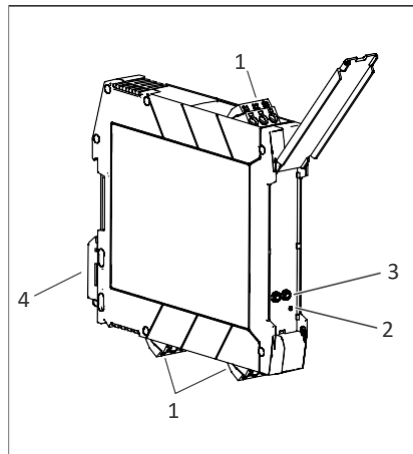

- 9 *Display and operating elements*
- 1 *Plug-in screw terminal*
 - 2 *Green LED "On", power supply*
 - 3 *Connection sockets for HART communication (channel 1)*
 - 4 *DIN rail clip for DIN rail mounting*

Local operation

Hardware settings / configuration

No manual hardware settings are required at the device for commissioning.

Attention must be paid to the different terminal assignment when connecting 2/4-wire transmitters. At the output side, the connected system is detected and automatic switching takes place between the active and passive mode.

12.10 Ordering information

Detailed ordering information is available from your nearest sales organization

www.acs-controlsystem.com

1. Select the product using the filters and search field.
2. Open the product page.
3. Select Configuration.

12.11 Accessories

Detailed ordering information is available from your nearest sales organization

www.acs-controlsystem.com

12.12 Certificates and approvals

 For certificates and approvals valid for the device: see the data on the nameplate

 Approval-related data and documents: www.acs-controlsystem.com

12.13 Supplementary documentation

The following document types are available in the Downloads area of the ACS website (www.acs-controlsystem.com):

Document type	Purpose and content of the document
Brief Operating Instructions (KA)	Guide that takes you quickly to the 1st measured value The Brief Operating Instructions contain all the essential information from incoming acceptance to initial commissioning.
Operating Instructions (BA)	Your reference document These Operating Instructions contain all the information that is required in the various life cycle phases of the device: from product identification, incoming acceptance and storage, to mounting, connection, operation and commissioning, through to troubleshooting, maintenance and disposal.
Safety Instructions (XA)	Depending on the approval, safety instructions for electrical equipment in hazardous areas are also supplied with the device. These are an integral part of the Operating Instructions. Information on the Safety Instructions (XA) that are relevant for the device is provided on the nameplate.

13 Appendix: system overview

13.1 Power supply

13.1.1 General information on the power supply



Read the information leaflet enclosed in the package of the individual products.

13.1.2 Power supply (24 to 230 V)

The ExTVA-600-U0 active barrier is available with an extended supply voltage range of 24 to 230 V_{AC/DC}. This module is powered individually and exclusively via the terminals on the device and is not suitable for power supply via the DIN rail bus connector.

13.2 Applications of the isolating amplifiers

This section describes the typical applications of the devices.

These devices perform various functions during signal conditioning:

- Amplification
- Normalization
- Filtering
- Galvanic isolation
- Supply of electrical power to connected sensors
- Line monitoring

The devices for these tasks are collectively known as isolating amplifiers or signal isolators and are available with different functions. Different types of signals are conditioned in this context.

13.2.1 Types of signals

Signals are referred to as analog signals if they can continuously assume every value between a minimum and maximum value (e.g. 0/4-20 mA) and are therefore also known as "value-continuous" signals. The value range in this interval is huge and is practically infinite in terms of measurement accuracy.

Electrical analog signals are generated with the help of a sensor, for example, which records the states, or changes of state, of physical variables and converts them to an electrical signal.

The following variables are typically measured in system and process engineering using ACS measuring instruments:

- Temperature
- Pressure
- Level
- Flow rate
- Analysis values (e.g. turbidity, conductivity, pH etc.)

These analog signals are evaluated in the controller (PLC) and the signals can be used in a "target device": e.g. for

- Display devices, e.g. level indication,
- Control unit, e.g. level control
- Actuators, e.g. to fill a tank

A transmitter can also be connected downstream of the sensor. This transmitter converts the analog measured value signal to a standard signal and thereby enables the further processing of the signal with additional standardized, electrical modules. The transmitter can also be integrated in the sensor housing.

Binary signals only assume two values and signal the states "on" or "off" / "1" or "0" with these values. Binary signals are often equated with "digital" signals because digital signals are generally binary encoded.

HART (Highway Addressable Remote Transducer) signals are essentially characterized by the fact that they are operated and used as a complement to classic analog standard signals, in contrast to other digital fieldbus systems. HART therefore does not replace point-to-point wiring but rather enables the integration of intelligent field devices. The digital signals are modulated onto an analog 4 to 20 mA standard current signal by means of HART modulation in order to transmit digital information in addition to the analog information of the process value.

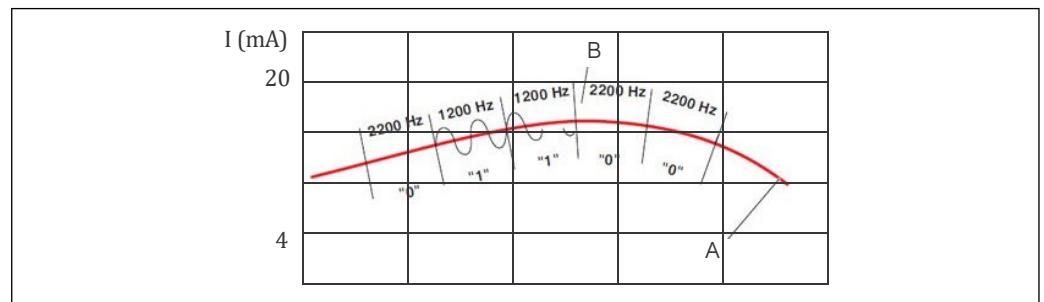

A0045578

10 Modulated HART signal

A Analog signal
B Digital signal

NAMUR sensors are operated with a transmitted current and have four states so that sensor errors can also be detected by an analog evaluation unit. This is sometimes referred to as the "closed circuit current principle".

NAMUR sensors can adopt four states at the output:

- Current 0 mA: wire break; circuit open
- Current <1.2 mA: sensor ready, undamped
- Current >2.1 mA: sensor ready, damped
- Current maximum value >6 mA: short-circuit, maximum current

13.2.2 ExTVA-600-U0 active barrier

The active barriers perform several functions. In addition to galvanic signal isolation and the proportional transmission of analog 0/4-20 mA signals, they also provide power to connected sensors. The ExTVA-600-U0 devices is HART-transparent, i.e. they also transmit the HART information. Via the HART connections on the front, HART signals can be measured or connected "SMART" sensors can be easily configured.

The following are examples of typical applications of the ExTVA-600-U0 active barrier. Each application is explained briefly and described in a schematic diagram.

Please note: the devices have an active and passive current input to which a 2-wire or 4-wire transmitter can be directly connected. The output of the device can be operated actively or passively. The current signal is then available to the PLC / controller or to other instrumentation.

Example: pressure measurement in a hazardous area

- The passive 2-wire sensor supplies a current signal proportional to the pressure to the active input of the ExTVA-600-U0 active barrier
- The ExTVA-600-U0 active barrier supplies an active current output signal proportional to the input signal to a passive input of the evaluation unit

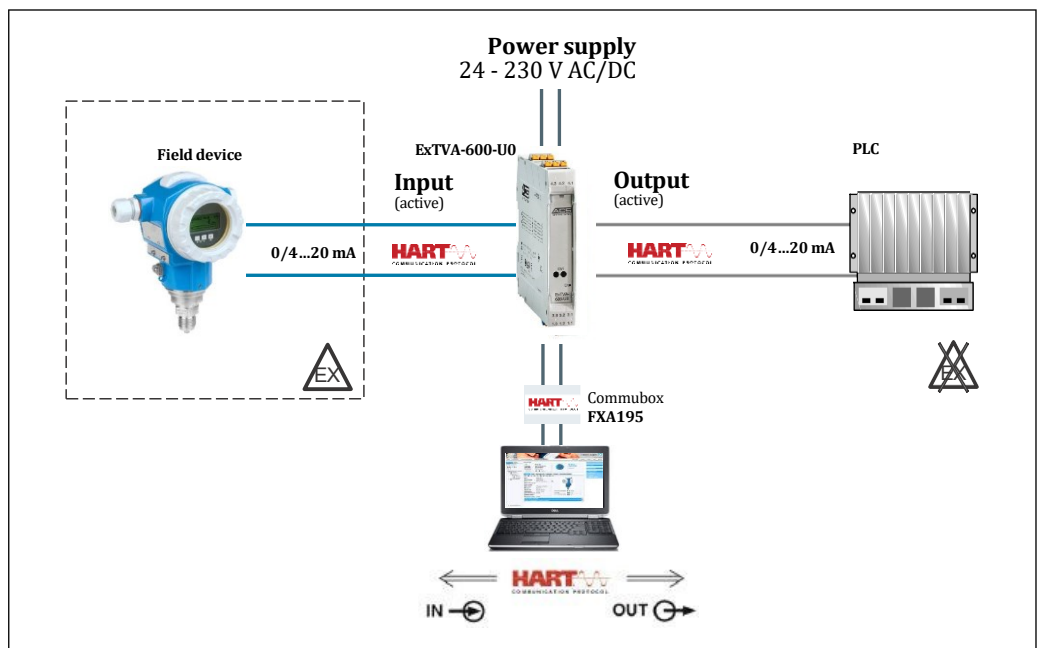

A0045917

11 Pressure measurement in a hazardous area

Flow measurement in a hazardous area

- The active 4-wire sensor supplies a current signal proportional to the flow to the passive input of the ExTVA-600-U0 active barrier
- The ExTVA-600-U0 active barrier supplies a passive current output signal proportional to the input signal to an active input of the evaluation unit

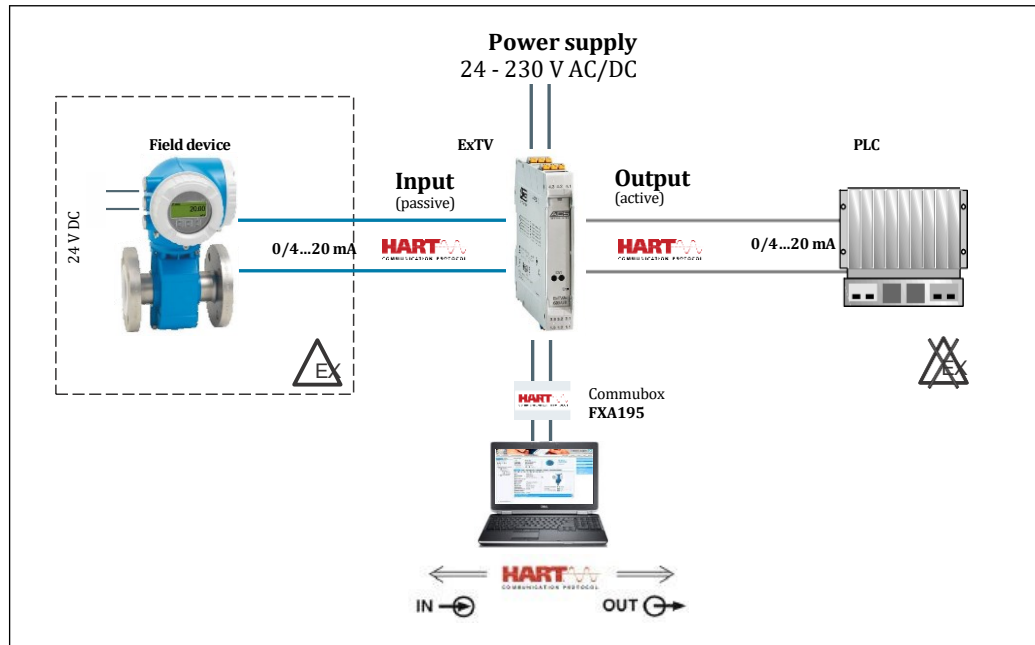

w12 Flow measurement in the hazardous area



FEEL FREE TO
CONTACT US

ACS Control-System GmbH
Lauterbachstr. 57
84307 Eggenfelden - Germany
info@acs-controlsystem.de
www.acs-controlsystem.com
+49 (0) 8721-9668-0

YOUR PARTNER FOR MEASUREMENT & AUTOMATION