

Brief Operating Instructions

ExTVA-600-U0

Active barrier, 1-channel for 4 to 20 mA, HART® transparent,
Supply 24 to 230 V_{AC/DC}, input and output active/passive, Ex certification

These Brief Operating Instructions are not a substitute for the Operating Instructions pertaining to the device. Detailed information can be found in the Operating Instructions and the additional documentation.

Available via:

- Internet: www.acs-controlsystem.com

Basic safety instructions

Requirements for the personnel

The personnel must fulfill the following requirements for its tasks:

- Trained, qualified specialists must have a relevant qualification for this specific function and task.
- Are authorized by the plant owner/operator.
- Are familiar with federal/national regulations.
- Before starting work, read and understand the instructions in the manual and supplementary documentation as well as the certificates (depending on the application).
- Follow instructions and comply with basic conditions.

Intended use

The active barrier is used for the safe isolation of 0/4 to 20 mA standard signal circuits. An intrinsically safe version is optionally available for operation in Zone

2. The device is designed for installation on DIN rails in accordance with IEC 60715.

Product liability: The manufacturer does not accept any responsibility for damage that results from non-designated use and from failure to comply with the instructions in this manual.

Operational safety

Risk of injury!

- Operate the device only if it is in proper technical condition, free from errors and faults.
- The operator is responsible for interference-free operation of the device.

Hazardous area

To eliminate danger to persons or the facility when the device is used in the hazardous area (e.g. explosion protection):

- Check the nameplate to verify if the device ordered can be put to its intended use in the hazardous area.
- Observe the specifications in the separate supplementary documentation that is an integral part of these instructions.

Product safety

This device is designed in accordance with good engineering practice to meet state-of-the-art safety requirements, has been tested, and left the factory in a condition in which it is safe to operate.

Installation instructions

- The device's IP20 degree of protection is intended for a clean and dry environment.
- Do not expose the device to mechanical and/or thermal stress that exceeds the specified limits.
- The device is intended for installation in a cabinet or similar housing. The device may only be operated as an installed device.
- To protect against mechanical or electrical damage, the device must be installed in an appropriate housing with a suitable degree of protection according to IEC/EN 60529.
- The device fulfills the EMC regulations for the industrial sector.

Incoming acceptance and product identification

Incoming acceptance

On receipt of the delivery:

1. Check the packaging for damage.
Report all damage immediately to the manufacturer.
Do not install damaged components.
2. Check the scope of delivery using the delivery note.
3. Compare the data on the nameplate with the order specifications on the delivery note.
4. Check the technical documentation and all other necessary documents, e.g. certificates, to ensure they are complete.



If one of the conditions is not satisfied, contact the manufacturer.

Product identification

The device can be identified in the following way:

- Nameplate specifications

Nameplate

Do you have the correct device?

The nameplate provides you with the following information on the device:

- Manufacturer identification, device designation
- Order code
- Extended order code

- Serial number
- Tag name (TAG) (optional)
- Technical values, e.g. supply voltage, current consumption, ambient temperature, communication-specific data (optional)
- Degree of protection
- Approvals with symbols
- Reference to Safety Instructions (XA) (optional)

▶ Compare the information on the nameplate with the order.

Name and address of manufacturer

Address of manufacturer:	Lauterbachstrasse 57, 84307 Eggenfelden or www.acs-controlsystem.com
Name of manufacturer:	ACS-Control-System GmbH

Mounting

Mounting requirements

Dimensions

Width (B) x length (L) x height (H) (with terminals): 17.5 mm (0.69 in) x 116 mm (4.57 in) x 107.5 mm (4.23 in)

Mounting location

The device is designed for installation on 35 mm (1.38 in) DIN rails in accordance with IEC 60715 (TH35).

NOTICE

- ▶ When using in hazardous areas, the limit values of the certificates and approvals must be observed.

Important ambient conditions

Ambient temperature range	-40 to 60 °C (-40 to 140 °F)	Storage temperature	-40 to 80 °C (-40 to 176 °F)
Degree of protection	IP 20	Overvoltage category	II

Electrical connection

Connecting requirements

A flat-blade screwdriver is required to establish an electrical connection to screw terminals.

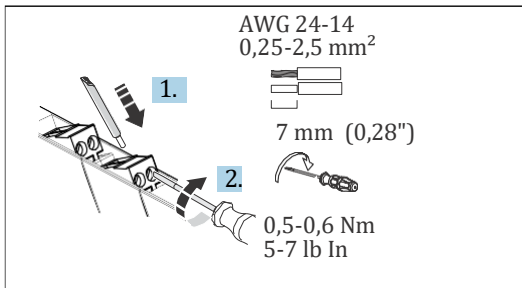

1 Electrical connection

CAUTION

Destruction of parts of the electronics

- ▶ Switch off the power supply before installing and connecting the device.

NOTICE

Destruction or malfunction of parts of the electronics

- ▶ ⚠ ESD - electrostatic discharge. Protect the terminals and HART sockets on the front from electrostatic discharge.
- ▶ A shielded cable is recommended for HART communication. Observe grounding concept of the plant.

i Only use copper cables with a minimum temperature rating of 75 °C (167 °F) as the connecting cables.

Storage and transport

Storage temperature: -40 to +80 °C (-40 to +176 °F)

Maximum relative humidity: < 95%

i Pack the device for storage and transportation in such a way that it is reliably protected against impact and external influences. The original packaging provides the best protection.

Avoid the following environmental influences during storage:

- Direct sunlight
- Proximity to hot objects
- Mechanical vibration
- Aggressive media

Pollution degree	2	Humidity	5 to 95 %
Operating altitude, hazardous area version	≤ 2000 m (6562 ft)	Operating altitude, non-hazardous area version	≤ 4000 m (13123 ft)
		Insulation class	Class II

Installing a DIN rail device

The device can be installed in any position (horizontal or vertical) on the DIN rail without lateral clearance from neighboring devices. No tools are required for installation. The use of end brackets the DIN rail is recommended as an end support for the device.

i When installing several devices side by side, it is important to ensure that the maximum side wall temperature of 80 °C (176 °F) of the individual devices is not exceeded. If this cannot be guaranteed, mount the devices at a distance from one another or ensure sufficient cooling.

Special connection instructions

- Disconnecting devices and auxiliary circuit protective systems with suitable AC or DC values must be provided within reach in the building installation.
- A switch/power circuit breaker must be provided close to the device and clearly marked as a disconnecting unit for this device.
- A circuit breaker (nominal current ≤ 10 A; break capacity 6 kA; e.g. type B) must be available within reach for the supply line.

Important connection data

Performance characteristics

Power supply¹⁾

Supply voltage	24 to 230 V _{AC/DC} (-20% / +10%, 0/50/60 Hz)
Power consumption	≤ 4.9 VA / 2.4 W (20 mA); ≤ 5 VA / 2.5 W (22 mA)
Power loss	≤ 2 W (20 mA); ≤ 2.1 W (22 mA)
Current consumption at 24 V _{DC}	≤ 0.1 A (20 mA); ≤ 0.1 A (22 mA)
Current consumption at 230 V _{AC}	≤ 0.02 A (20 mA); ≤ 0.02 A (22 mA)

1) The data apply for the following operating scenario: input active / output active / output load 0 Ω. When external voltages are connected to the output, the power loss in the device may increase. The power loss in the device can be reduced by connecting an external output load.

Input data

Input signal range (underrange / overrange)	0 to 22 mA
Function range, input signal	0/4 to 20 mA
Transmitter supply voltage	≥ 16.5 V / (20 mA)

Output data

Output signal range (underload/overload range)	0 to 22 mA
Function range, output signal	0/4 to 20 mA
Transmission behavior	1:1 to input signal
Step reponse (10 to 90 %)	≤ 1 ms
Load	≤ 500 Ω (for active mode)
Transmissible communication protocols	HART

Accuracies

Transmission error max. (0 to 20.5 mA)	< 0.1 % / of full scale value (< 20 µA)
Temperature coefficient	< 0.01 % /K

Galvanic isolation

Power supply to input/output	Testing voltage: 3 000 V _{AC} 50 Hz, 1 min
Input to output	Testing voltage: 1 500 V _{AC} 50 Hz, 1 min

 For detailed technical data, see the Operating Instruction

Quick wiring guide

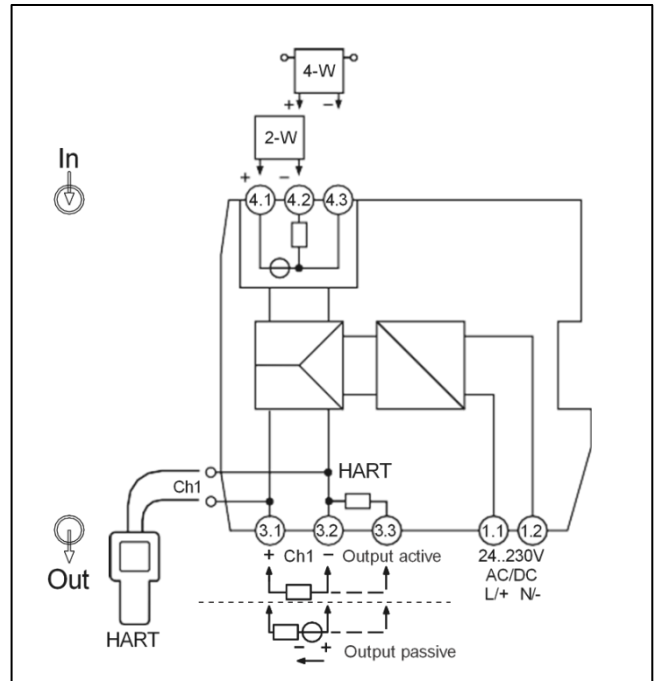

2 Terminal assignment

Connection for operation with active output:

1. Connect + to 3.1.
2. Connect - to 3.2.

Switching of the mode of operation occurs automatically.

Connection for operation with passive output:

1. Connect + to 3.2.
2. Connect - to 3.1.

Switching of the mode of operation occurs automatically.

 HART communicators can be connected to the HART connection sockets. Ensure that there is an adequate external load (≥ 230 Ω) in the output circuit. If the external load is not sufficient, an internal 250 Ω communication resistor can be added to the measuring loop via the alternative terminal assignment (terminal 3.3.) to use the HART connection sockets.

Connecting the supply voltage

The power is supplied via terminals 1.1 and 1.2.

Display and operating elements

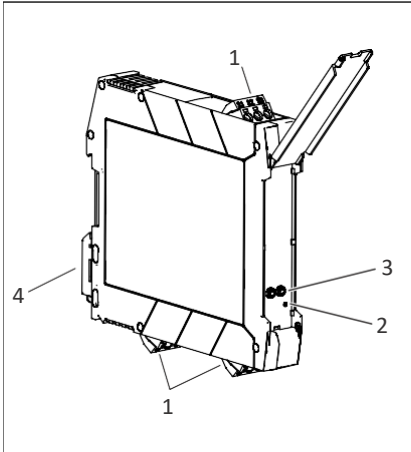

3 Display and operating elements

- 1 Plug-in screw terminal
- 2 Green LED "On", power supply
- 3 Connection sockets for HART communication (channel 1)
- 4 DIN rail clip for DIN rail mounting

Local operation

Hardware settings / configuration

No manual hardware settings are required at the device for commissioning.

Attention must be paid to the different terminal assignment when connecting 2/4-wire transmitters. At the output side, the connected system is detected and automatic switching takes place between the active and passive mode.

Maintenance and cleaning

No special maintenance work is required for the device.

Cleaning of surfaces not in contact with the medium

- Recommendation: Use a lint-free cloth that is either dry or slightly dampened using water.
- Do not use any sharp objects or aggressive cleaning agents that corrode the surfaces (displays, housing, for example) and seals.

- Do not use high-pressure steam.
- Observe the degree of protection of the device.



The cleaning agent used must be compatible with the materials of the device configuration. Do not use cleaning agents with concentrated mineral acids, bases or organic solvents.