

OPERATING MANUAL - BA05.24

Hydrolog HLF4

Data logger with data remote transmission
for water level recording



Index	
1. About this document	3
1.1. Dokument function	3
1.2. Terms	3
1.3. Other documents	3
2. Safety instructions	4
2.1. Authorized personnel	4
2.2. Appropriate use	4
2.3. Operational safety	4
3. Product description	5
3.1. Function	5
3.2. Construction	5
3.3. Product label	6
3.4. Product code	6
3.5. Dimensions	6
3.6. Packaging, transport, storage	7
3.7. Accessories	8
3.7.1. Antennas	8
3.7.2. Batteries	8
3.7.3. PV module	8
3.7.4. Mounting accessories, connection cable	8
3.7.5. Level pipe caps	8
4. Installation	9
4.1. Ambient and process conditions	9
4.2. Installation place	9
4.3. Installation notes	9
4.4. Open the device	9
4.5. Close the device	9
5. Electrical connection	10
5.1. Terminals	10
5.2. Terminal assignment	10
5.2.1. Auxiliary power supply	11
5.2.2. Transmitter power supply - Uo1/Uo2/Uo3/Uo4	12
5.2.3. Measuring input analogue - Ai1/Ai2	12
5.2.4. Communication input RS485 Modbus-RTU - Ci1/Ci2	12
5.2.5. Digital input switch / counter - Di1	12
6. Operation	13
6.1. Bluetooth®	13
6.2. Cellular communication	13
7. Error diagnosis and Troubleshooting	14
8. Maintenance	14
8.1. Battery change	14
9. Repair	15
9.1. Dismounting	15
9.2. Return	15
9.3. Disposal	15
10. Technical Data	16
10.1. Auxiliary power supply	16
10.2. Inputs	16
10.2.1. Analogue - Current 0/4...20mA	16
10.2.2. Communication - RS485 Modbus-RTU	16
10.2.3. Digital - Switch / Counter	16
10.2.4. Transmitter power supply Uo	16
10.3. Outputs	16
10.3.1. Interface - Bluetooth®	16
10.3.2. Interface - Cellular LTE-M1 / LTE-NB2 / EGPRS	16
10.4. Data logger	17
10.4.1. Memory	17
10.4.2. Time	17
10.5. Environmental conditions	17
10.6. Materials	17
11. Revision	18

1. About this document

1.1. Dokument function

These instructions for use describe the structure, functions and the use of the product and will help to operate the product as intended.

Read these instructions carefully before using the product. This is to avoid possible damage to persons, property or the device.

The Operating manual is part of the device and must be kept always accessible nearest its installation location.

All statements within this document correspond to the information available at the time of printing. Subject to change without prior notice.

1.2. Terms

NOTE	Notes to prevent failures, malfunctions, damage to devices or plants.
WARNING	Non-observance of the information may result in serious or fatal personal injury.
[04-5]	Exemplary notice to a type variant (>> chapter Product description - Product code)

1.3. Other documents

Besides this document the following material can be found on the Internet at www.acs-controlsystem.com:

- EU Declaration of Conformity (current version)
- Manufacturer declarations
- Certificates
- 3D-CAD models

2. Safety instructions

2.1. Authorized personnel

Installation, electrical connection, commissioning, operation, maintenance, dismantling and disposal of the device must be made by a qualified and authorized expert according to the information's in the Operating manual and the relevant standards and rules.

This expert must have read and understood the Operating manual and especially the safety instructions. During work on and with the device, the required personal protective equipment must always be worn.

2.2. Appropriate use

The device is an electronic data logger with integrated data remote transmission, for autonomous recording of different measurands.

The device may not be used in areas where the using of mobile phones is not allowed, e.g. in hospitals or explosive hazardous areas. Electromagnetically sensitive devices can be interfered in their operation because of the high energetic radio waves at the moment of data transmission.

The operational reliability of the device is ensured only at the intended use. Inappropriate or incorrect use of this product can give risk to application specific hazards, e.g. vessel overflow through incorrect mounting or adjustment. Damage to property and persons or environmental contamination can result. Also, the characteristics of the instrument can be impaired.

An inappropriately use, disregarding the Operating manual and the technical rules, using under-qualified personnel, making unauthorized alterations as well as damage of the device releases the manufacturer from liability for any resulting damage. This renders the manufacturer's warranty null and void.

2.3. Operational safety

The device is safely built and tested according to state-of-the-art technology. The instrument must only be operated in a technically flawless and reliable condition. The operator is responsible for the trouble-free operation of the instrument. The device may only be used within the permitted operation limits. Every use besides these limits as agreed can lead to serious dangers.

The materials of the device must be checked for compatibility with the respective application requirements before use. An unsuitable material can lead to damage, abnormal behavior or destruction of the device and to the resulting dangers.

The sensors may not be used as sole device for prevention of dangerous conditions in machines and plants.

For safety and warranty reasons, any invasive work on the device beyond that described in the Operating manual may be carried out only by personnel authorized by the manufacturer. Arbitrary conversions or modifications are explicitly forbidden. For safety reasons, only the accessory specified by the manufacturer must be used.

The device meets the legal requirements of all relevant EU directives. This is confirmed by attaching the CE mark to the device. The associated EU-Declaration of Conformity can be ordered or downloaded from the homepage.

3. Product description

3.1. Function

The device is an electronic data logger with integrated data remote transmission, for autonomous recording of different measurands.

The priority use of the device is local independent measurement value recording and data remote transmission of level probes, ultrasonic sensors or similar sensors, which are suitable for water level measurement.

The device was especially developed for measuring in slim tubes from 2".

The connected sensors, analogue with current signal 0/4...20mA or digital RS485 Modbus RTU or impulse / switch input are supplied by the device with energy and the recorded measurement values are stored internally loss-protected.

The data transmission of the measuring values to the ACS-Web-Portal or to an FTP server is made automatically per mobile communication.

Innovative alarm management allows to detect and to report risks due to flooding or low water punctually.

The energy supply of the device can be made either by a high performance battery, a Li-ION rechargeable battery, possibly in combination with a PV module or by an external direct voltage.

The device is hermetically sealed and is floodable up to 3m.

The parameterization and operation can be made by the integrated Bluetooth® interface or by the ACS-Web-Portal.

3.2. Construction

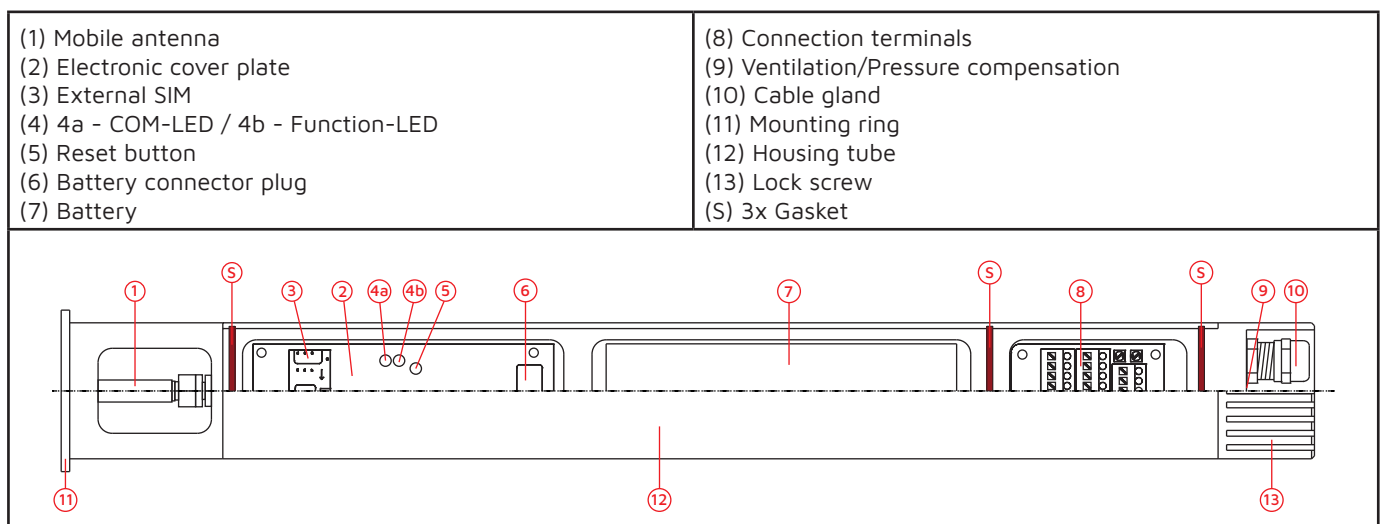

The mobile radio antenna (1) can be unscrewed and replaced with another one, e.g. a level pipe cap or directional radio antenna.

The electronics is located under a cover plate (2). A push-pull SIM card holder (3) is mounted on this to alternatively accommodate an external SIM card. The integrated SIM card should preferably be used.

Two function LEDs (4) signal different operating states.

COM-LED for cellular communication

Function-LED for various informations

Reset button (5) for restart of the device. ATTENTION: Use only in exceptional cases! Risk of data loss!

The high-performance battery (7) or the LiION rechargeable battery (7) used ensures a reliable energy supply for the device for many years, depending on use. The connection is made via a socket (6)

Up to 5 sensors, a PV module and/or an auxiliary power supply are connected via 3 cable glands (10) and the connection terminals (8).

The reference air supply required for a relative pressure measurement occurs via a hydrophobic/oleophobic membrane via the waterproof pressure compensation opening (9).

The device is hung directly into a 2" level pipe cap in the system using the hanging ring (11). Installation in larger caps is done using adapter plates.

The housing tube (12), the locking screw (13) and 3 gaskets (S) seal the device watertight up to 3m flooding.

A laser marking of the product label ensures the identifiability of the device throughout the entire lifetime.

3.3. Product label

The product label contains the most important data for identification and use of the instrument.

①	Hydrolog HLF4SR2B24MX2S S/N: 482569/2024	⚠	⑤	(1) Product code
②	⚡ Us = LiSOCl2 35Ah / DC 7...32V	⚡ Uo = 2x 16,6V/30mA		(2) Serial number
	⚡ Ci = 2x RS485 Modbus RTU	⚡ Uo = 2x 6,7V/100mA		(3) Technical data supply / input
③	⚡ Ai-I = 2x 0/4...20mA	⚡ Co = Bluetooth® 5.2	④	(4) Technical data output
	⚡ Di = 1x Count/Switch	⚡ Co = LTE-M / NB-IoT / EGPRS		(5) Safety notes
	84307 Eggenfelden / Germany www.acs-controlsystem.com		⑥	(6) Approvals

3.4. Product code

HLF4 [01][02][03][04][05][06][07][95][98]

01	Approval	S	Standard
02	Enclosure type	R2	In-tube enclosure Ø 48mm / tube 2"
03	Electronic – Supply	B1	Battery lithium 19Ah / DC supply 7...32V
03		B2	Battery lithium 35Ah / DC supply 7...32V
03		A1	Rechargeable battery Li-ION 20Ah / DC supply 7...32V / PV module
04	Electronic – Function	0	Bluetooth® 5.2
04		5	LTE-M, NB-IoT, EGPRS / Bluetooth® 5.2
05	Electronic – Input	M	2x Ai 0/4...20mA / 2x Ci RS485 / 1x Di
06	Tariff	0	Separate billing / without
06		XS1B	ACS DataComplete XS, Basic
06		XS1S	ACS DataComplete XS, Standard
06		XS1P	ACS DataComplete XS, Premium
06		S1B	ACS DataComplete S, Basic
06		S1S	ACS DataComplete S, Standard
06		S1P	ACS DataComplete S, Premium
06		M1B	ACS DataComplete M, Basic
06		M1S	ACS DataComplete M, Standard
06		M1P	ACS DataComplete M, Premium
06		L1B	ACS DataComplete L, Basic
06		L1S	ACS DataComplete L, Standard
06		L1P	ACS DataComplete L, Premium
07		S	Standard
95	Additional option	-ML	Measurement point designation / TAG – Laser marking
98	Additional option	-KF	Configuration / Preset

Differing versions are normally marked by the character Y at the product code.

3.5. Dimensions

Dimensions in mm

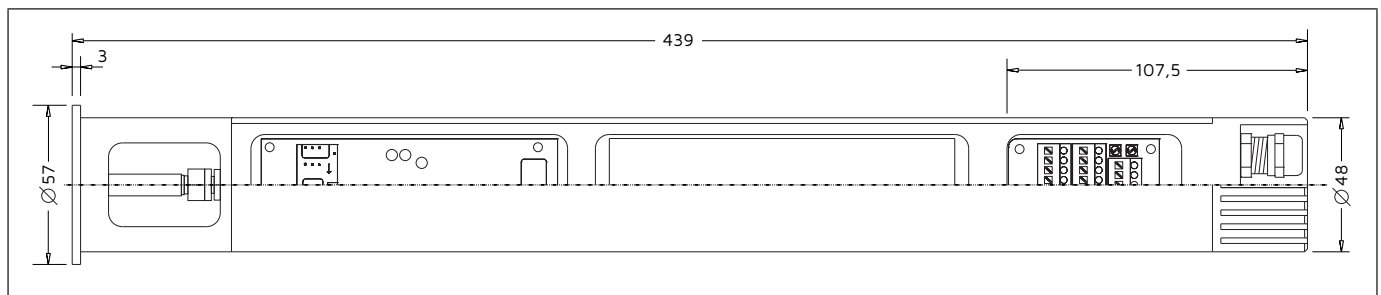

3.6. Packaging, transport, storage

The device is protected by packaging. It can handle normal loads during transport. Transport must be carried out in due consideration of the notes on the transport packaging.

Nonobservance of these instructions can cause damage to the device.

The delivery must be checked for completeness and possible transit damage immediately at receipt. Ascertained transit damage or concealed defects must be appropriately dealt with.

Up to the time of installation, the packages must be left closed and, unless otherwise indicated, must be stored only under the following conditions:

- Not in the open
- Dry and dust free
- Not exposed to corrosive media
- Protected against solar radiation
- Avoiding mechanical shock and vibration
- Storage and transport temperature -20...+85°C
- Relative humidity 20...85%

3.7. Accessories

3.7.1. Antennas

Art.No.	Description
611000539	Rod antenna, screw mounting, connection cable 5m, mounting bracket
611000540	Dome antenna, screw mounting, connection cable 3m
611000552	Dome antenna for 2" level pipe cap, screw mounting, connection cable shortened
611000599	Dome antenna for 3" / 4" level pipe cap, screw mounting, connection cable shortened
611000600	Dome antenna for 5" / 6" level pipe cap, screw mounting, connection cable shortened
611000541	Flat antenna, adhesive mounting, connection cable 3m
611000662	Directional antenna R1-LTE, antenna gain 7-9dBi, wall or mast mounting, connection cable 5m
611000665	Directional antenna R2-LTE, antenna gain 9-11dBi, wall or mast mounting, connection cable 10m
911001827	Antenna extension cable, L=5m, cable RG58, 2x circular SMA connectors

3.7.2. Batteries

Art.No.	Description
611000566	Battery BAT19AH, lithium 19Ah
611000567	Battery BAT35AH, lithium 35Ah
611000569	Rechargeable battery AKKU20AH, LiION 20Ah
611000629	Charger 230Vac (90...264Vac) for LiION rechargeable battery, output voltage 24Vdc/1A/24W

3.7.3. PV module

Art.No.	Description
911001822	SM10W01, voltage 12V, power 10 watts

3.7.4. Mounting accessories, connection cable

Art.No.	Description
611000610	Strain relief sensor (total sensor weight > 1kg)
611000549	Adapter plate for 3" / 4" ACS level caps, outer diameter 107.5mm
611000550	Adapter plate for 4 1/2" / 5" ACS level caps, outer diameter 136mm
611000551	Adapter plate for 6" ACS level caps, outer diameter 158mm
611000578	Pole/wall mount for solar module SM10W01, tiltable -5...+30°, tube diameter 30...63mm
611000630	Connection cable PV module - HLF4, 2-wire, 5m, UV resistant

3.7.5. Level pipe caps

Art.No.	Description
121000006	VK-A-200-0 level cap, painted aluminum, thread 2", 6-point closure
	VK-A-300-0 level cap, painted aluminum, thread 3", 6-point closure
	VK-A-400-0 level cap, painted aluminum, thread 4", 6-point closure
	VK-A-412-0 level cap, painted aluminum, thread 4 1/2", 6-point closure
	VK-A-500-0 level cap, painted aluminum, thread 5", 6-point closure
	VK-A-600-0 level cap, painted aluminum, thread 6", 6-point closure

4. Installation

4.1. Ambient and process conditions

The correct function of the device within the specific technical data can only be guaranteed, if the permitted ambient conditions at the installation place (» chapter Technical Data) will not be exceeded.
 Make sure before mounting that all parts of the instrument (e.g. enclosure, cable glands, seals) are suitable for the existing conditions (e.g. temperature, mechanical influences).

4.2. Installation place

The installation place has substantial influence to the quality of the mobile communication connection. Especially near buildings, vegetation, covering by leaves or snow can damp or even block the signal.

Before installation the signal strength of the mobile network at the installation place must be checked. At insufficient mobile network strength a data transmission can be impossible and there will be exhausted essentially more battery capacity. This will considerably reduce the run time of the device. By use of an optimal mounted external antenna or eventually a directional antenna the signal strength can be substantially increased. The antenna must be protected against covering by leaves or snow resp. must be cleaned if necessary. Eventually another installation place must be chosen.

At running water in the case of high water there is the increased danger of damaging due to driftwood, e.g. tree trunks. A sufficient mechanical protection must be provided or eventually another installation place must be chosen.

4.3. Installation notes

Do not remove packaging until just before mounting and check the device for any damage.

The device can be inserted into level pipe caps for water level tubes 2", into wider level pipe caps by adapter plates.

The construction of the device allows damage protected flooding up to 3m water column.

NOTE	Pollution or damaging of the pressure compensation opening (enclosure bottom side) can lead to faulty measuring results of a connected hydrostatic water level sensor.
NOTE	At very cold temperatures rising moisture can lead to strong icing at the bottom side of the device and thus to a sealing of the pressure compensation element. This can be reduced substantially by installing a breathable foam part into the water level tube.
NOTE	Before inserting the device into the level pipe check if all cable glands, the enclosure tube and the antenna plug are tightly screwed.
NOTE	Connected sensors should slide slowly into the water level pipe. An unbraked falling sensor can lead to an overload of the strain relief.
NOTE	Suspension sensors from ACS with electrical connection option H - cable assembly Hydrolog and length L1, in combination with the data logger, result in the installation length L1 based on the hanging edge of the level tube cap or adapter plate.

4.4. Open the device

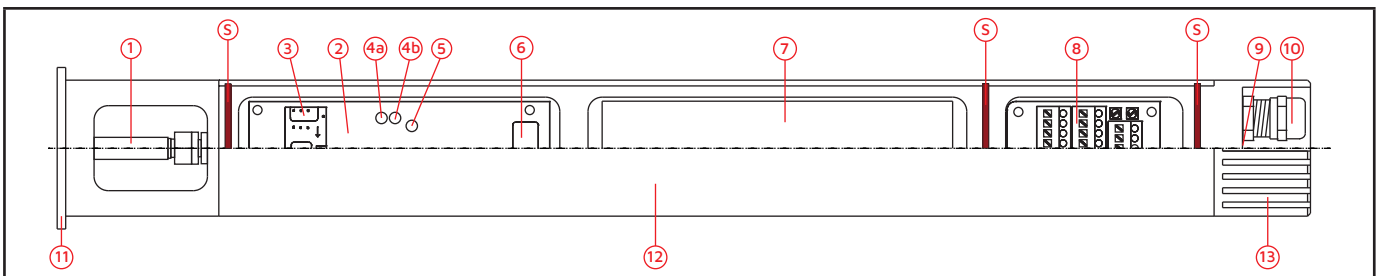

Release lock screw (13) counterclockwise and pull off together with housing tube (12).

NOTE	Avoid the pollution of the internal area of the device with humidity or dirt, otherwise this can lead to abnormal behavior, damage or destruction and to the resulting dangers.
-------------	---

4.5. Close the device

If necessary, lightly coat 3x seals (S) all around with a suitable, silicone-compatible lubricant to enable the housing tube to be moved easily. Replace damaged seals. These are available from the manufacturer.

Slide on the housing tube (12) and fix it hand-tight with the lock screw (13) turning clockwise.

5. Electrical connection

NOTE	Instructions for opening the device - Section 4.4. and closing the device - Section 4.5.
NOTE	Install the device only when power supply is off. Switch off DC supply.
NOTE	The cable of the connected sensor is sealed by the cable gland, but is not held securely. To safely prevent slipping, for example, a steel core, the cable shield or even unused strands must be clamped in the double screw blocks located on the side of the 5-pin terminal. These serve to provide strain relief up to a maximum of 1kg sensor weight. Sensors weighing more than 1 kg must be secured using the additional heavy-duty strain relief. This high-load strain relief is available separately as an accessory.

5.1. Terminals

	<p>Uo1/2/3/4 - Sensor supply 4 channels Ai1-I - Analogue input current 0/4-20mA - channel 1 Ai2-I - Analogue input current 0/4-20mA - channel 2 Di1 - Digital switch / count input - channel 1 Ci1-A+/B- - Interface RS485 Modbus-RTU - channel 1 Ci2-A+/B- - Interface RS485 Modbus-RTU - channel 2 GND - reference potential</p> <p>+DC/-DC - Auxiliary power DC voltage +PV/-PV - PV module NC - not connected</p> <p>fixing clamp - strain relief up to 1kg sensor weight</p>
--	---

The terminals are suitable for connection of:

Solid conductor / fine-wire conductor	0,2...1,5mm ²
Fine-wire conductor with ferrule	0,25...1,0mm ²
Stripping length	8,5...9,5mm
Clamping area cable gland	2x 4...8mm / 1x 3,5...5mm

5.2. Terminal assignment

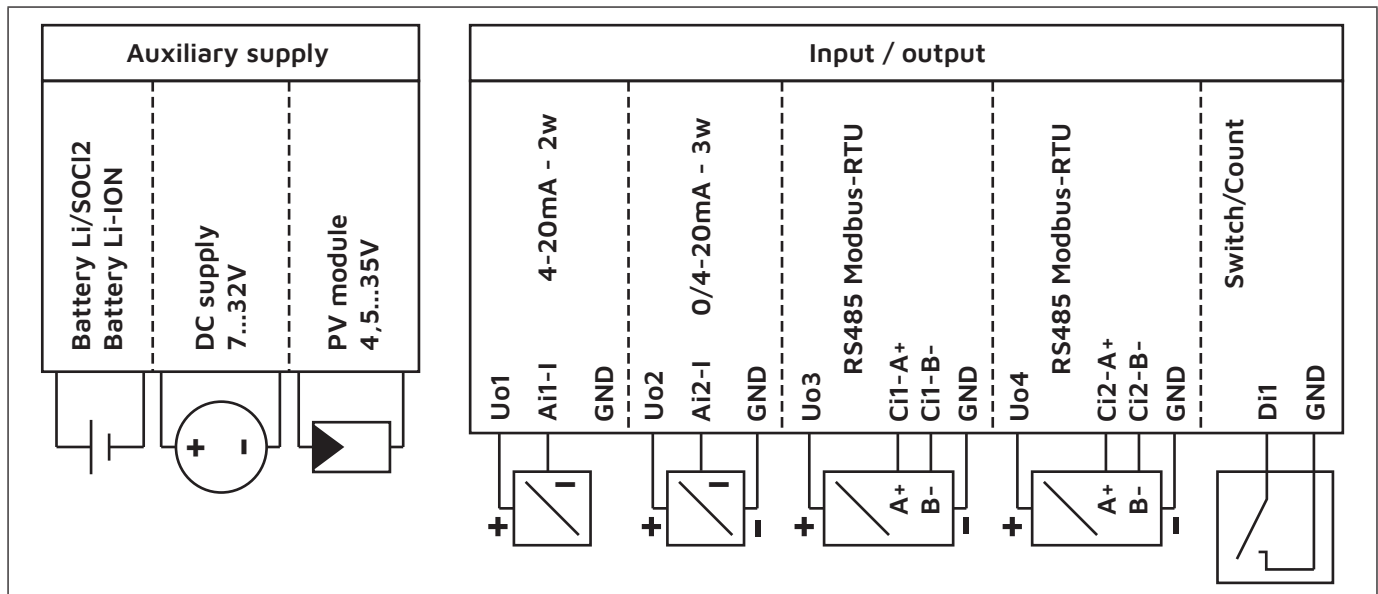

5.2.1. Auxiliary power supply

WARNING	Only suitable batteries may be used, otherwise this can lead to abnormal behavior, damage or destruction of the device and to the resulting dangers.
WARNING	The primary battery may not be charged. There is explosion or fire hazard.
NOTE	Charging the rechargeable battery can be made: <ul style="list-style-type: none"> • internal devices by a connected suitable PV module or a connected direct voltage. • external devices by a suitable DC power supply.
NOTE	The plug of the connection cable to the battery can be only pulled off after releasing the locking lever at the plug jack.
NOTE	For modification from primary to rechargeable battery the three retaining clips must be removed.

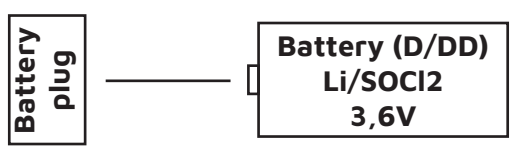
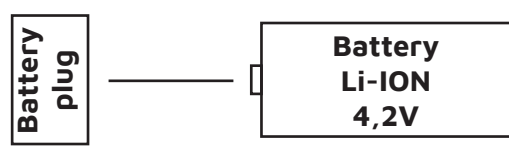
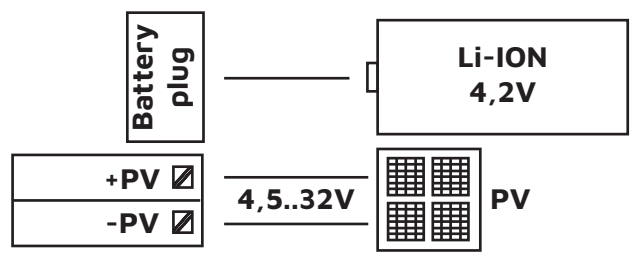
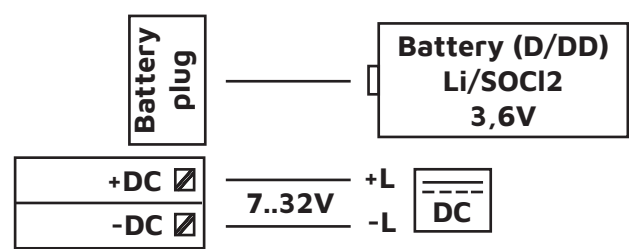
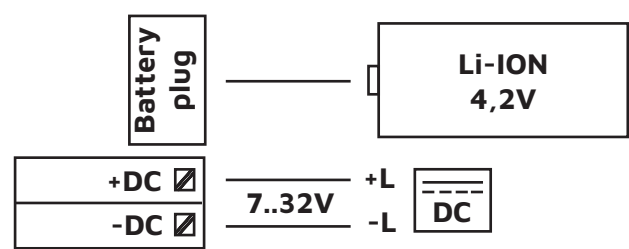
<p>Battery The battery is the only source of energy. Requires replacement when battery is low.</p> 	<p>Li-ION rechargeable battery The rechargeable battery is the only source of energy. Recharging required when battery level is low.</p> 
	<p>Li-ION rechargeable battery / PV module The rechargeable battery is the main source of energy. The rechargeable battery is recharged by the PV module.</p> 
<p>DC supply / Battery The DC supply is the main source of energy. The battery takes over the energy supply if the DC supply fails. Battery replacement required when battery is low.</p> 	<p>DC supply / Li-ION rechargeable battery The DC supply is the main source of energy. The rechargeable battery takes over the energy supply if the DC supply fails. The rechargeable battery is recharged via the DC supply.</p> 

5.2.2. Transmitter power supply - Uo1/Uo2/Uo3/Uo4

Note	The outputs Uo1...Uo4 are used for temporarily limited sensor supply.
-------------	---

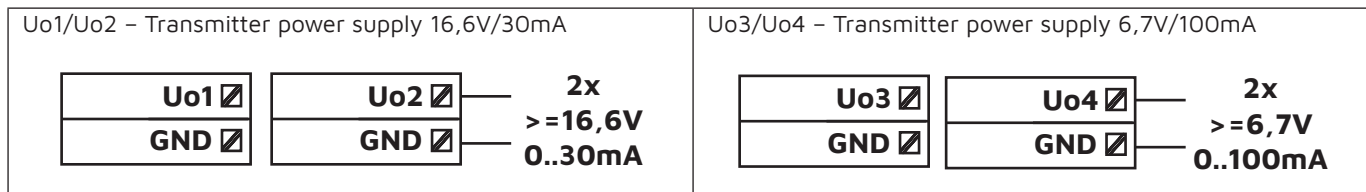

5.2.3. Measuring input analogue - Ai1/Ai2

HINWEIS	The connection diagrams apply to standard sensors. By the user specific sensor configuration the use of the current saving sensor supplies Uo3/Uo4 is possible.
----------------	---

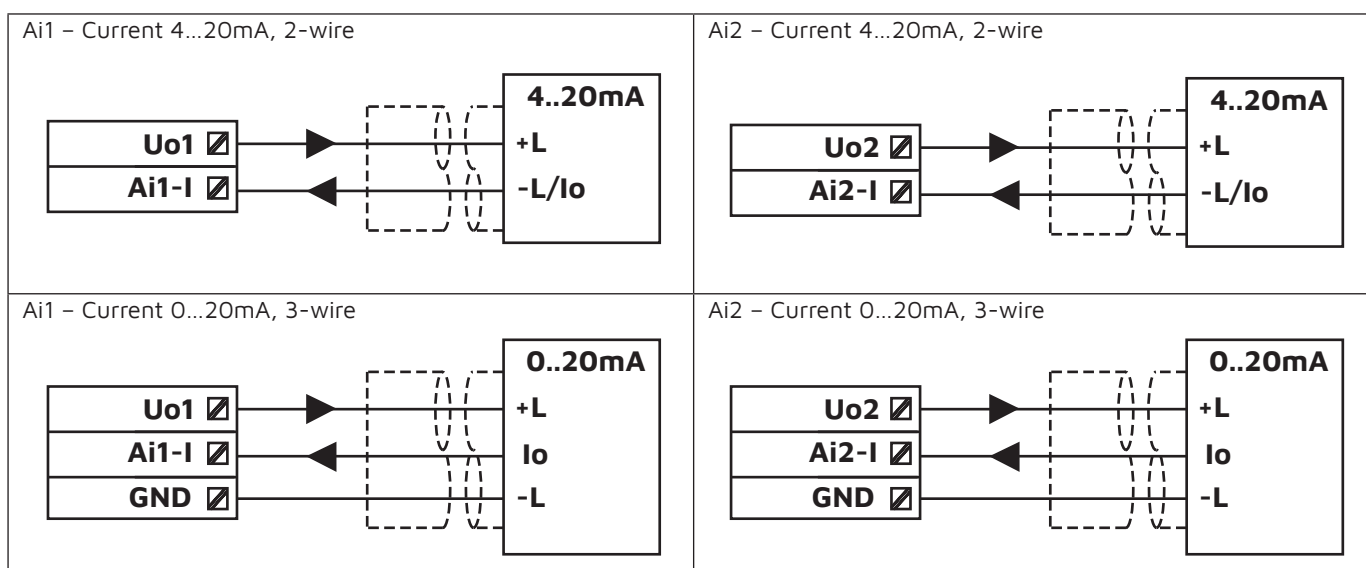

5.2.4. Communication input RS485 Modbus-RTU - Ci1/Ci2

Note	The connection diagrams apply to standard sensors. By the user specific sensor configuration the use of the sensor supply with higher voltage Uo1/Uo2 is possible.
-------------	--

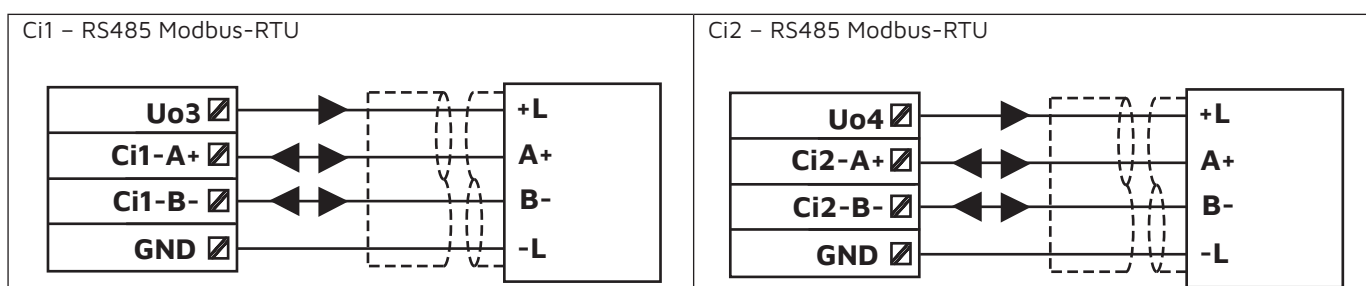

5.2.5. Digital input switch / counter - Di1

Note	The input can be configured as control input (e.g. a float switch) as well as impulse counter (e.g. a flow meter)
-------------	---

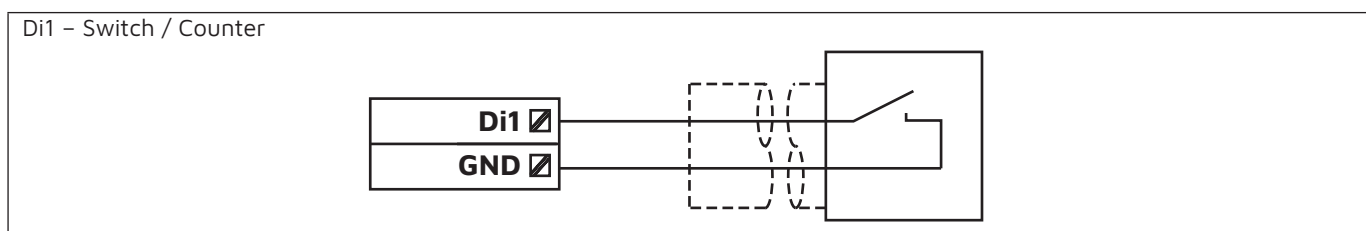

6. Operation

NOTE	Instructions for opening the device - Section 4.4. and closing the device - Section 4.5.
-------------	--

NOTE	<p>The configuration of the device contributes significantly to the energy consumption of the device. An unfavourable configuration can reduce the runtime.</p> <p>The most important factors for the runtime of the device are:</p> <ul style="list-style-type: none"> • Frequency of the mobile communication • Quality of the mobile network • Frequency of measuring value logging • Supply current of the sensors • On-time of the sensors
-------------	--

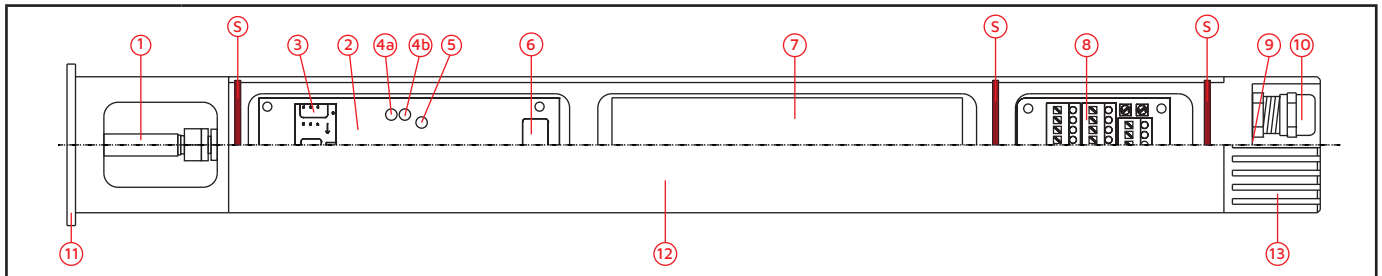

NOTE	<p>An activated communication connection is signaled internally the device by cyclic flashing of Function-LED (4b) and COM-LED (4a).</p> <p>Function-LED (4b):</p> <ul style="list-style-type: none"> • 100ms on / 100ms off: Data transmission • 500ms on / 500ms off: Connection Bluetooth® • 1000ms on / 1000ms off: Connected with portal <p>COM-LED (4a):</p> <ul style="list-style-type: none"> • 1800ms on / 200ms off: Connected to mobil network • 200ms on / 1800ms off: Searching mobile network • 125ms on / 125ms off: Data transmission
-------------	---

NOTE	In the case of a fail function, the device can be reset by an internal RESET pushbutton. The successful restart is signaled by a double flash of the Function-LED (4b).
-------------	---

6.1. Bluetooth®

NOTE	The operation device must be equipped with Bluetooth® 4.1 and higher, recommended is Bluetooth® 4.2 and higher.
-------------	---

NOTE	<p>The operation is made per app ACS-SmartConnect, which must be loaded and installed from app stores. The password for the first access is the device serial number.</p> <p>Due to safety reasons the assignment of an own safe password is suggested.</p>
-------------	---

6.2. Cellular communication

NOTE	To use the online portal, activation of the integrated SIM card is required.
-------------	--

NOTE	<p>An embedded SIM card is installed at the factory and is permanently linked to the ACS WEB portal. If you want to use your own SIM card, it must be inserted into the SIM card holder (3) and activated using the app ACS-SmartConnect.</p> <p>By using your own SIM card, you lose the ability to transfer the data to the ACS WEB portal and thus also all the functionalities of the WEB portal. The collected measured values are then transferred to an FTP server to be provided by the user.</p>
-------------	---

NOTE	At the initial dial-up of the device at a provider in a non-german foreign country, the initial registration at the regional mobile network is necessary. Dependent on the country and the provider this can while up to several minutes. To reduce the energy load for the battery, the action "connection test" at the menu item "service" must be run by the app ACS-SmartConnect.
-------------	---

7. Error diagnosis and Troubleshooting

The operator of the system is responsible for taking suitable measures to rectify faults.

In case of malfunction check:

Component / area	Check	Troubleshooting
Enclosure	Damage	Replace device or send in for repair
Pressure compensation opening	Pollution	Replace device or send in for repair
	Damage	Replace device or send in for repair
Battery	Low charge level	Replace battery / charge rechargeable battery
	Contact	Replace battery resp. connection cable
	Damage	Replace battery
Antennea	Contact	Replace antenna resp. send in for repair
	Damage	
Cable	Short circuit	Replace cable
	Wire break	Send in the connected device for repair
	Damage	
Supply voltage DC	Operating voltage available	Switch-on resp. repair operating voltage
		Check terminals resp. repair
	Operating voltage reverse connected	Reverse operation voltage connection
	Operating voltage too low	Adapt resp. repair
	Operating voltage too high	Send in the device for repair
	Connection cable damaged	Replace or repair cable

If the malfunction cannot be eliminated, please contact the manufacturer.

8. Maintenance

At appropriate use, the device is free of maintenance.

If energy consumption increases, it may be necessary to replace the battery used or to recharge the rechargeable battery externally.

A rechargeable battery can also be recharged during operation using a connected PV module or DC direct voltage. This eliminates the need for external recharging.

8.1. Battery change

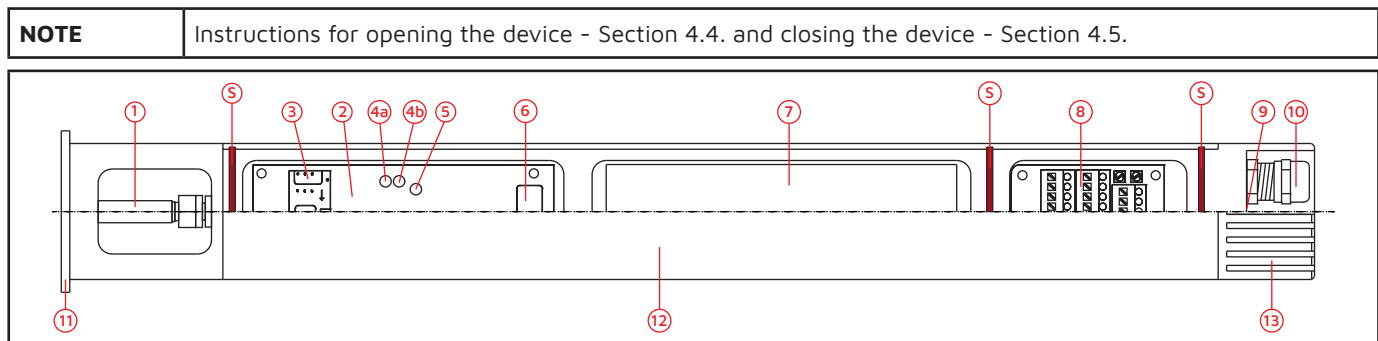

Remove the plug of the battery connecting cable from the socket (6). The plug of the connecting cable to the battery can only be removed after pressing the locking lever on the plug socket.

Remove the battery and also disconnect the cable from the battery.

Attach the cable to the new battery and insert the new battery into the battery compartment (7).

Insert the plug of the battery connecting cable into the socket (6).

9. Repair

The device is not intended for repair by the user. A repair may only be carried out by the manufacturer.

9.1. Dismounting

Use suitable protective clothing, e.g. goggles, gloves.

WARNING	Let the device and the system cool down sufficiently fore dismounting it. There is a risk of hot surfaces as well as dangerous and hot media escaping.
----------------	--

WARNING	Dismount the device only when the system is pressureless. There is a risk of fast escaping media resp. pressure blow.
----------------	---

9.2. Return

Returns can only be accepted if the device has been equipped with a Decontamination declaration enclosed. The decontamination declaration is available at <https://www.acs-controlsystem.com> at the download area and must be completely filled in, and affixed securely and weather-proof to the outside of the packaging.

9.3. Disposal



As required by the Directive 2012/19/EU on waste electrical and electronic equipment (WEEE), products of ACS are marked with the depicted symbol in order to minimize the disposal of WEEE as unsorted municipal waste. Such products may not be disposed of as unsorted municipal waste and can be returned to ACS for disposal.

The return follows the conditions stipulated in the General Terms and Conditions or as individually agreed by ACS.

10. Technical Data

Reference conditions	Ta = +15°C..+25°C (+59°F..+77°F) / pa = 860..1060kPa / r.F. = 45..75% ton = 240s / Battery 35Ah
Measurement deviation	EN/IEC 60770-1: Characteristic deviation – Limit value adjustment

10.1. Auxiliary power supply

Battery B1	Lithium / 3,6V-19Ah
Battery B2	Lithium / 3,6V-35Ah
Battery rechargeable A1	LiION / 4,1V-20Ah
Supply voltage DC	7...32VDC / ≤ 350mA
PV module	4,5...32VDC / ≤ 2A

10.2. Inputs

10.2.1. Analogue - Current 0/4...20mA

Signal range Ai1/Ai2	0/4...20mA / FSI: 0...28mA / Ri 27R
Resolution	FSI 16 Bit
Characteristic deviation	≤ ±0,05% FSI
Temperature deviation	≤ ±0,1% FSI / 10K
Long term deviation	≤ ±0,05% FSI / year

10.2.2. Communication - RS485 Modbus-RTU

Interface Ci1 / Ci2	RS485, bidirectional / Modbus-RTU / 9600 Baud (4800...38400 Baud)
Input resistance	96kΩ

10.2.3. Digital - Switch / Counter

Operating range Di1	≤ 20kOhm / ≤ 1kHz
---------------------	-------------------

10.2.4. Transmitter power supply Uo

Output voltage Uo1/Uo2	16,6V ±0,3V (0mA) / 15,9V ±0,3V (30mA) / 0...30mA, max. 40mA
Output voltage Uo3/Uo4	6,7V ±0,2V (0mA) / 6,6V ±0,2V (100mA) / 0...100mA, max. 300mA

10.3. Outputs

10.3.1. Interface - Bluetooth®

Standard	Bluetooth® 5.2
Spezifikation	2Mbit/s, Advertising Mode 2s
Transmit power	≤ 0,1W
Range	Outdoor max. 200m / Indoor max. 40m

10.3.2. Interface - Cellular LTE-M1 / LTE-NB2 / EGPRS

Standard	4G LTE-M1
	LTE-FDD: B1/B2/B3/B4/B5/B8/B12/B13/B18/B19/B20/B25/B26/B27/B28/B66/B85
	4G LTE-NB2 (NB-IoT)
	LTE-FDD: B1/B2/B3/B4/B5/B8/B12/B13/B18/B19/B20/B25/B28/B66/B71/B85
Priority	2G EGPRS
	850/900/1800/1900MHz
Priority	4G (LTE-M1 or LTE-NB2), fallback 2G (EGPRS)
Transmit power	4G ≤ 0,2W
	2G ≤ 2W
SIM	Internal SIM + external Micro-SIM
Antenna connector	Connector SMA / 500ohm

10.4. Data logger

10.4.1. Memory

Type	Dataflash, nonvolatile
Memory size	8 MB
Memory content	≥ 800.000 measuring values

10.4.2. Time

Cycle accuracy	≤ ±4 seconds / month, internet time synchronization 1x/day
	≤ ±2 minutes / month, without internet time synchronization
Frequency base	Quartz

10.5. Environmental conditions

Ambient temperature Ta	-20...+60°C (-4°F...+140°F)
	[03-A1] rechargeable battery Lilon charge temperature 0...+45°C (+32°F...+113°F), internally limited
Protection level	IP68 [≤3m/≤0,3bar] (EN/IEC 60529)
Climatic classification	4K4H (EN/IEC 60721-3-4)
Shock classification	15g [11ms] (EN/IEC 60068-2-27)
Vibration classification	4g [10...2000 Hz] (EN/IEC 60068-2-6)
EM compatibility	Operation device class B / Industrial range (EN/IEC 61326)
Altitude above sea level	2000m above sea level
MTTF	258 years
Weight	0,9kg

10.6. Materials

Processwetted	PA, aluminum/PES lacquered, PUR, brass, nickel, silicone, NBR
---------------	---

11. Revision

Version	Changes
BA02.20/TI02.20	Original version
BA02.20/TI12.20	Technical data: <ul style="list-style-type: none">• Auxiliary supply PV module 4,5...32V / \leq 2A• Change channel labels I>>i / O>>o• Input analogue signal range 0/4...20mA Produkt code: <ul style="list-style-type: none">• Electronic – supply – A1: 20Ah
BA05.23	Integration BA/TI - full rework Change: <ul style="list-style-type: none">• Option [04-4] - LTE Cat-1, EGPRS• Option [04-5] - LTE-M1, LTE-NB2, EGPRS



FEEL FREE TO
CONTACT US

ACS-CONTROL-SYSTEM GmbH
Lauterbachstr. 57
84307 Eggenfelden - Germany
info@acs-controlsystem.de
www.acs-controlsystem.com
+49 (0) 8721-9668-0