

OPERATING MANUAL - BA12.25

---

## Hydrocont HP4SC

Hydrostatic filling level transmitter,  $\varnothing 22\text{mm}$   
with capacitive ceramic pressure measuring sensor,  
temperature sensor and conductivity sensor



<b>Index</b>	
<b>1. About this document</b>	<b>3</b>
1.1. Dokument function	3
1.2. Terms	3
1.3. Other documents	3
<b>2. Safety instructions</b>	<b>4</b>
2.1. Authorized personnel	4
2.2. Appropriate use	4
2.3. Operational safety	4
<b>3. Product description</b>	<b>6</b>
3.1. Function	6
3.2. Construction	6
3.3. Product label	6
3.4. Product code	7
3.5. Dimensions	8
3.6. Packaging, transport, storage	9
3.7. Accessories	9
<b>4. Installation</b>	<b>10</b>
4.1. Ambient and process conditions	10
4.2. Installation place	10
4.3. Installation notes	10
<b>5. Electrical connection</b>	<b>11</b>
5.1. Electronic output [09-A]/[09-X] – Current 4...20mA, FSK	11
5.1.1. Function	11
5.1.2. Terminal assignment	11
5.1.3. Connection cable	11
5.1.4. Connection notes	12
5.1.5. Analogue output Io	12
5.2. Electronic output [09-V] – RS485 Modbus-RTU	12
5.2.1. Function	12
5.2.2. Terminal assignment	13
5.2.3. Connection cable	13
5.2.4. Connection notes	13
<b>6. Operation</b>	<b>14</b>
6.1. Electronic output [09-A] – Current 4...20mA, FSK	14
6.2. Electronic output [09-V] – RS485 Modbus-RTU	14
6.2.1. Parameter	14
<b>7. Error diagnosis and Troubleshooting</b>	<b>15</b>
<b>8. Maintenance</b>	<b>15</b>
8.1. Calibration conductivity sensor	15
<b>9. Repair</b>	<b>15</b>
9.1. Dismounting	15
9.2. Return	15
9.3. Disposal	15
<b>10. Technical Data</b>	<b>16</b>
10.1. Inputs	16
10.1.1. Input pressure/fill level [08-##]	16
10.1.2. Input temperature [10-1] – Pt100, 3-wire	16
10.1.3. Input temperature [10-3]/[10-4] – Pt1000	16
10.1.4. Input conductivity [10-4]	17
10.2. Ausgänge	17
10.2.1. Electronic output [09-A] – Current 4...20mA, FSK	17
10.2.2. Electronic output [09-V] – RS485 Modbus-RTU	17
10.3. Environmental conditions	18
10.4. Materials	18
<b>11. Revision</b>	<b>19</b>

## 1. About this document

### 1.1. Dokument function

These instructions for use describe the structure, functions and the use of the product and will help to operate the product as intended.

Read these instructions carefully before using the product. This is to avoid possible damage to persons, property or the device.

The Operating manual is part of the device and must be kept always accessible nearest its installation location.

All statements within this document correspond to the information available at the time of printing. Subject to change without prior notice.

### 1.2. Terms

<b>NOTE</b>	Notes to prevent failures, malfunctions, damage to devices or plants.
<b>WARNING</b>	Non-observance of the information may result in serious or fatal personal injury.
<b>[04-5]</b>	Exemplary notice to a type variant (>> chapter Product description - Product code)

### 1.3. Other documents

Besides this document the following material can be found on the Internet at [www.acs-controlsystem.com](http://www.acs-controlsystem.com):

- EU Declaration of Conformity (current version)
- Manufacturer declarations
- Certificates
- Parameter lists
- 3D-CAD models

## 2. Safety instructions

### 2.1. Authorized personnel

Installation, electrical connection, commissioning, operation, maintenance, dismantling and disposal of the device must be made by a qualified and authorized expert according to the information's in Operating manual and relevant standards.

This expert must have read and understood the Operating manual and especially the safety instructions. During work on and with the device, the required personal protective equipment must always be worn.

If the device is intended for use in explosion-hazardous areas, the safety instructions for electrical apparatus for explosion-hazardous areas must be observed in particular.

### 2.2. Appropriate use

The device is an electronic hydrostatic filling level transmitter for monitoring, control and continuous measurement of filling levels, temperatures and conductivities in liquids.

The operational reliability of the device is ensured only at the intended use. Inappropriate or incorrect use of this product can give risk to application specific hazards, e.g. vessel overflow through incorrect mounting or adjustment.

Damage to property and persons or environmental contamination can result. Also, the characteristics of the instrument can be impaired.

An inappropriately use, disregarding the Operating manual and the technical rules, using under-qualified personnel, making unauthorized alterations as well as damage of the device releases the manufacturer from liability for any resulting damage. This renders the manufacturer's warranty null and void.

### 2.3. Operational safety

The device is safely built and tested according to state-of-the-art technology. The instrument must only be operated in a technically flawless and reliable condition. The operator is responsible for the trouble-free operation of the instrument. The device may only be used within the permitted operation limits. Every use besides these limits as agreed can lead to serious dangers.

The materials must be checked for compatibility with the application requirements before use.

An unsuitable material can lead to damage, abnormal behavior or destruction of the device and to the resulting dangers.

The sensors may not be used as sole device for prevention of dangerous conditions in machines and plants.

For safety and warranty reasons, any invasive work on the device beyond that described may be carried out only by personnel authorized by the manufacturer. Arbitrary conversions or modifications are explicitly forbidden. For safety reasons, only the accessory specified by the manufacturer must be used.

The device meets the requirements of all relevant EU directives. This is confirmed by attaching the CE mark to the device. The associated EU-Declaration of Conformity can be ordered or downloaded from the homepage.

### 2.4. Operating supplies for explosive hazardous areas

If a device is installed and operated in explosive hazardous areas, the general Ex construction standards (EN/IEC 60079-14, VDE 0165), this operating manual as well as the EU type examination certificate resp. the IECEx certificate of conformity incl. supplements must be observed.

The installation of explosive hazardous systems must be carried out by specialist staff.

The devices are conceived for measuring of filling levels in explosive hazardous areas.

The measured medium may also be combustible liquids, gases, fogs, vapors or dusts.

Permitted maximum values of the intrinsically safe circuits:

Voltage	U <sub>i</sub>	30V
Current	I <sub>i</sub>	300mA
Power	P <sub>i</sub>	900mW
Effective internal capacitance	C <sub>i</sub>	1,3nF + (200pF/m * L <sub>c</sub> )
Effective internal inductivity	L <sub>i</sub>	5μH + (6,5μH/m * L <sub>c</sub> )
Maximum extension cable length	L <sub>c</sub>	60m

The intrinsically safe signal and supply circuit is earthen for safe technical function. Provide sufficient potential compensation along the complete cable way. Connect cable shield with the potential compensation of the explosive hazardous area. Install the intrinsically safe circuit earth free.

At variants of the devices with chargeable plastic parts, a warning marking points out to the safety measures, that must be applied because of the electrostatic charging in operation and especially in the case of maintenance activities:

- avoid friction
- no dry cleaning
- no assembling in pneumatic conveying stream

If there is a potential danger due to swinging or oscillating, the device must be effectively secured against these dangers.

### CATEGORY 1

The device in the version Electronic-Output [09-X] may be installed in explosive hazardous areas, where Category 1 equipment is required.

Devices of category 1 may be operated in hazardous explosive areas that require apparatus of category 1 only if atmospheric conditions are present (temperatures see tables below, pressure from 0,8 bar to 1,1 bar).

Devices of category 1 must be connected to intrinsically safe circuits of protection level ia.

### CATEGORY 2

The device in the version Electronic-Output [09-A] resp. [09-X] may be installed in explosive hazardous areas, where Category 2 equipment is required.

Devices of category 2 can be connected to intrinsically safe circuits of protection level ib.

For applications that require EPL Ga or Gb equipment, the following values apply:

(ATEX) / IECEx – Marking	Ambient temperature range resp. Medium temperature range
(II 1 G) Ex ia IIC T6 Ga (II 2 G) Ex ib IIC T6 Gb	-20°C...+42°C
(II 1 G) Ex ia IIC T5 Ga (II 2 G) Ex ib IIC T5 Gb	-20°C...+57°C
(II 1 G) Ex ia IIC T4...T1 Ga (II 2 G) Ex ib IIC T4...T1 Gb	-20°C...+70°C

For applications that require EPL Da or Db equipment, the following values apply:

(ATEX) / IECEx – Marking	Ambient temperature range at the electronic enclosure Tamb
II 1 D Ex ia IIIC T <sub>200</sub> 100°C Da	-20 °C ... +35 °C
II 1 D Ex ia IIIC T <sub>200</sub> 120°C Da	-20 °C ... +55 °C
II 2 D Ex ib IIIC T80°C Db	-20 °C ... +42 °C
II 2 D Ex ib IIIC T95°C Db	-20 °C ... +57 °C
II 2 D Ex ib IIIC T108°C Db	-20 °C ... +70 °C

### 3. Product description

#### 3.1. Function

The device is an electronic hydrostatic filling level transmitter for monitoring, control and continuous measurement of filling levels and temperatures in liquids.

The device is suitable for applications in virtually all industries for filling and water level measurement, especially for fresh water, wastewater and salt water. The slim construction design allows the use especially at confined space conditions, e.g. at bore holes and wells with small diameter.

The high precise, long term stable and robust ceramic measuring cell, the stainless steel enclosure and the thick-walled, length stable extension cable with highly stressable steel core ensures reliable precise measuring values and allows the operation also at demanding environmental conditions, e.g. low temperatures or high shock and vibration stress.

The hydrostatic liquid pressure acts directly (dry system) via the process membrane on the capacitor attached to the rear and causes a change in capacity, which is further processed.

For optional measuring the temperature, an integrated long-term stable platinum temperature sensor is used. The measured temperature value can be read out at the version RS485 Modbus-RTU by the digital interface or the resistance signal can be evaluated at the version current 4...20mA FSK in parallel to the pressure conditioned analogue current signal per 3-wire-technology.

For optional measuring the conductivity, a 4-electrode-sensor is used, which ensures accurate and reliable temperature-compensated measurement over a wide conductivity range, even when dirty.

The parameterization and operation can be made by the integrated wired interface.

#### 3.2. Construction

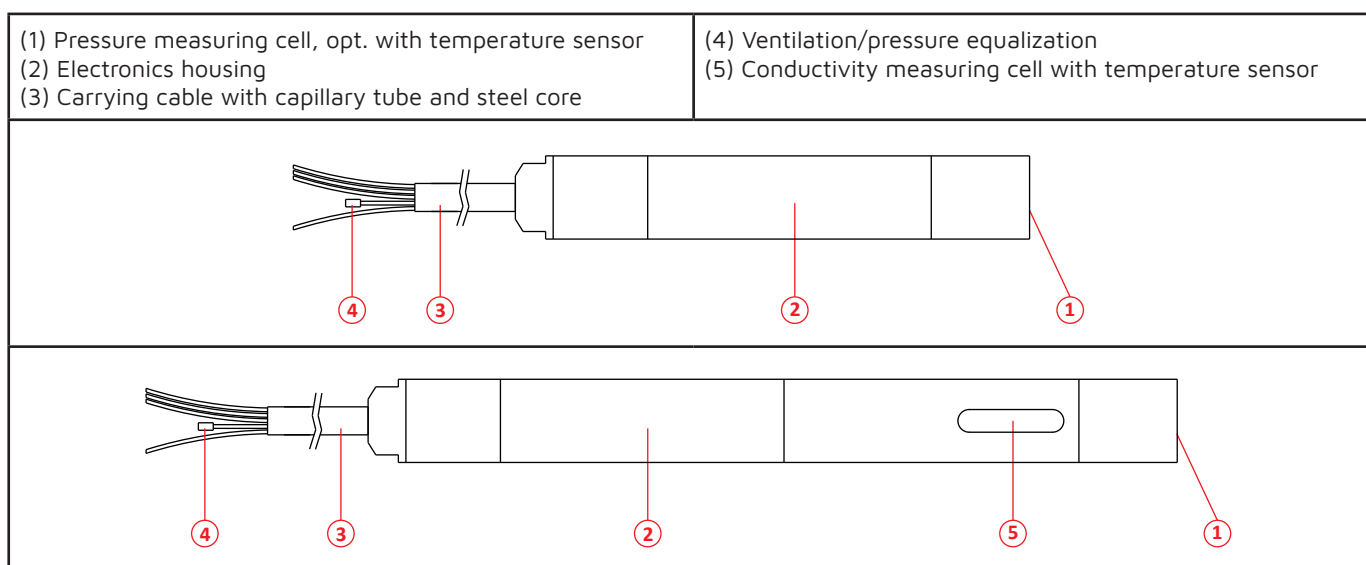

Ceramic pressure membrane (1) for recording the hydrostatic fluid pressure. A platinum temperature sensor that is thermally very well coupled to the metallic housing wall is optionally integrated.

Optional conductivity measuring cell (5) with integrated platinum temperature sensor.

The fully cast signal processing electronics is located in the housing tube (2).

Longitudinal carrying cable (3) with steel core and shielding braid. The reference air supply required for a relative pressure measurement takes place via a capillary tube with a filter attachment (4) integrated into the carrying cable.

A laser marking of the product label on the housing tube (2) ensures the identifiability of the device throughout the entire lifetime.

#### 3.3. Product label

The product label contains the most important data for identification and use of the instrument.

<div style="display: flex; justify-content: space-between;"> <div style="width: 60%;"> <p><b>①</b> HP4SCX01V005X00R1KA-10000</p> <p><b>②</b> S/N: 482569/2025</p> <p><b>③</b> <math>U_s = 9..30VDC</math>    RD = L+</p> <p><math>\pi_i = 0..1bar</math>        BK = L-/lo</p> <p><math>I_o = 4..20mA</math>        YE/GN = PE/PA</p> <p><math>C_{io} = FSK</math></p> <p style="text-align: right;"><b>④</b></p> <p><b>ACS</b> 84307 Eggenfelden / Germany www.acs-controlsystem.com</p> </div> <div style="width: 35%;"> <p>CE 0408 <b>⑤</b></p> <p><b>⑥</b></p> <p><b>⑦</b></p> <p>TÜV 25 ATEX 403790 X-00 / 2025 IECEx TUN 25.0011X-00 / 2025</p> <p>II 1 G Ex ia IIC T6...T1 Ga II 1 G Ex b IIC T6...T1 Gb II 1 D Ex ia IIC T200°C Da II 1 D Ex b IIC T80°C Db</p> </div> </div>	<p>(1) Product code</p> <p>(2) Serial number</p> <p>(3) Technical data supply / input</p> <p>(4) Electrical connection</p> <p>(5) Approvals</p> <p>(6) Safety notes</p> <p>(7) Ignition protection type</p>
---	---

### 3.4. Product code

#### HP4 [01][02][03][04][05][06][07][08][09][10][11][12][13][14][15][80][94/95/96/97/98/99]

	Device	HP4	Fill level sensor D22mm
01	Version	S	Standard
02	Sensor / material diaphragm	C	capacitive – front-flush / ceramic Al2O3 99,9%
03	Approval	S	Standard
03		X	ATEX/IECEX: II 1 G Ex ia IIC T6...T1 Ga / II 1 D Ex ia IIIC T <sub>200</sub> 100°C Da
03		Z	ATEX/IECEX: II 2 G Ex ib IIC T6...T1 Gb / II 2 D Ex ib IIIC T80°C Db
04	Process connection	0	without
05	Material process seal	1	FKM/FPM
05		3	EPDM, FDA listed
06	Material process connection	V	CrNi-steel
06		D	CrNi-steel, duplex, sea water resistant
07	Terminal enclosure	0	without
08	Measuring range (PV)	01	0...100 mbar
08		02	0...200 mbar
08		03	0...400 mbar
08		04	0...600 mbar
08		05	0...1 bar
08		07	0...2 bar
08		08	0...4 bar
08		09	0...6 bar
08		10	0...10 bar
08		12	0...20 bar
08		0A	0...1 mwc
08		0B	0...2 mwc
08		0C	0...4 mwc
08		0M	0...5 mwc
08		0D	0...6 mwc
08		0E	0...10 mwc
08		0F	0...20 mwc
08		0L	0...25 mwc
08		0G	0...40 mwc
08		0J	0...50 mwc
08		0K	0...60 mwc
08		0H	0...100 mwc
09	Electronic – Output	A	Current 4...20mA, FSK, 2-wire, over voltage protection - [03-S/Z]
09		X	Current 4...20mA, FSK, 2-wire - [03-S/X]
09		V	RS485 Modbus-RTU, 4- wire, over voltage protection - [03-S]
10	Electronic – Function	0	without
10		1	Temperature Pt100 class B, 3-wire – IEC 60751 - [03-S]/[09-A/X]
10		3	Temperature -20°C...+70°C (-4°F... +158°F) - [09-V]
10		4	Temperature -20°C...+70°C (-4°F... +158°F) - [09-V] Conductivity 0...50mS/cm [09-V]
11	Process temperature	0	-20°C...+70°C (-4°F... +158°F)
12	Pressure type (PV)	R	Gauge pressure
13	Measuring accuracy (PV)	1	0,2%
13		3	0,1%, linearization protocol
13		6	Xcellence – 0,05% [08 ≥ 200mbar/2mWS], linearization protocol
14	Electrical connection	K	Cable, confection wires
14		H	Cable, confection Hydrolog HLF4
14		O	Cable, without confection
15	Material extension cable	A	Cable sheath PE
15		B	Cable sheath PUR
80	Length L1	-###.###	mm (≤ 300.000mm)
94	Additional option	-SF	LABS-free, silicone-free / paint compatible version
95	Additional option	-ML	Measurement point designation / TAG – Laser marking
96	Additional option	-MZ	Material test certificate – EN10204 3.1
97	Additional option	-WT	Factory certification – drink water suitability
98	Additional option	-KF	Configuration / Preset
99	Additional option	-WK	Factory calibration – calibration certificate

Differing versions are normally marked by the character Y at the product code.

### 3.5. Dimensions

Dimensions in mm

Electrical connection 14-K Confection wires	Electrical connection 14-H Confection Hydrolog HLF4	Electrical connection 14-O Without confection
Electronic function [10-4] Option conductivity	Electronic function [10-4] Option conductivity	Electronic function [10-4] Option conductivity
<p> <math>L1 + 240\text{mm}</math>  <math>\varnothing 22</math>  <math>\varnothing 7.4</math>  <math>136</math>  <math>[10-4] 246</math> </p>	<p> <math>L1 - 400\text{mm}</math>  <math>\varnothing 22</math>  <math>\varnothing 7.4</math>  <math>136</math>  <math>[10-4] 246</math> </p>	<p> <math>L1</math>  <math>\varnothing 22</math>  <math>\varnothing 7.4</math>  <math>136</math>  <math>[10-4] 246</math> </p>

### 3.6. Packaging, transport, storage

The device is protected by packaging. It can handle normal loads during transport. Transport must be carried out in due consideration of the notes on the transport packaging.

Nonobservance of these instructions can cause damage to the device.

The delivery must be checked for completeness and possible transit damage immediately at receipt. Ascertained transit damage or concealed defects must be appropriately dealt with.

Up to the time of installation, the packages must be left closed and, unless otherwise indicated, must be stored only under the following conditions:

- Not in the open
- Dry and dust free
- Not exposed to corrosive media
- Protected against solar radiation
- Avoiding mechanical shock and vibration
- Storage and transport temperature -20...+85°C
- Relative humidity 20...85%

### 3.7. Accessories

For installation and electrical connection an extensive portfolio, that is optimally matched to the device is available:

- Mounting clamp
- Mounting screw
- Welding sockets
- Reduction adapter
- Gaskets
- Connection cables
- Confectionable connection jacks
- Field enclosure
- RS-485 interface converter
- FSK-USB interface converter

## 4. Installation

### 4.1. Ambient and process conditions

The correct function of the device within the specific technical data can only be guaranteed, if the permitted ambient and process conditions at the installation place (see chapter Technical Data) will not be exceeded. Hence make sure before mounting that all parts of the instrument exposed to the process (e.g. measuring membrane, process seal, enclosure, extension cable) are suitable for the existing process conditions (e.g. process pressure, process temperature, chemical properties of the medium, abrasion, mechanical influences).

### 4.2. Installation place

The device should be installed at a point free from flow and turbulence, or a guide tube should be used. The internal diameter of the guide tube should be at least 1 mm bigger than the outer diameter of the device.

Install device below the lowest measuring point.

Do not mount the device in the fill flow, in the suction area of a pump, in the tank outlet or at a point in the container which could be affected by pressure pulses from an agitator.

The installation of the device should be made if possible at temperature calmed places. High process temperature steps can produce short-time higher measuring signal deviations.

At underrun of the dew point, e.g. cold process medium at high environmental temperature, there is the possibility of condensate formation within the pressure measuring sensor, which can lead to temporary increased measurement deviations resp. malfunctions. These deviations are fully reversible by drying the condensate.

The cable must end in a dry room or a suitable terminal box.

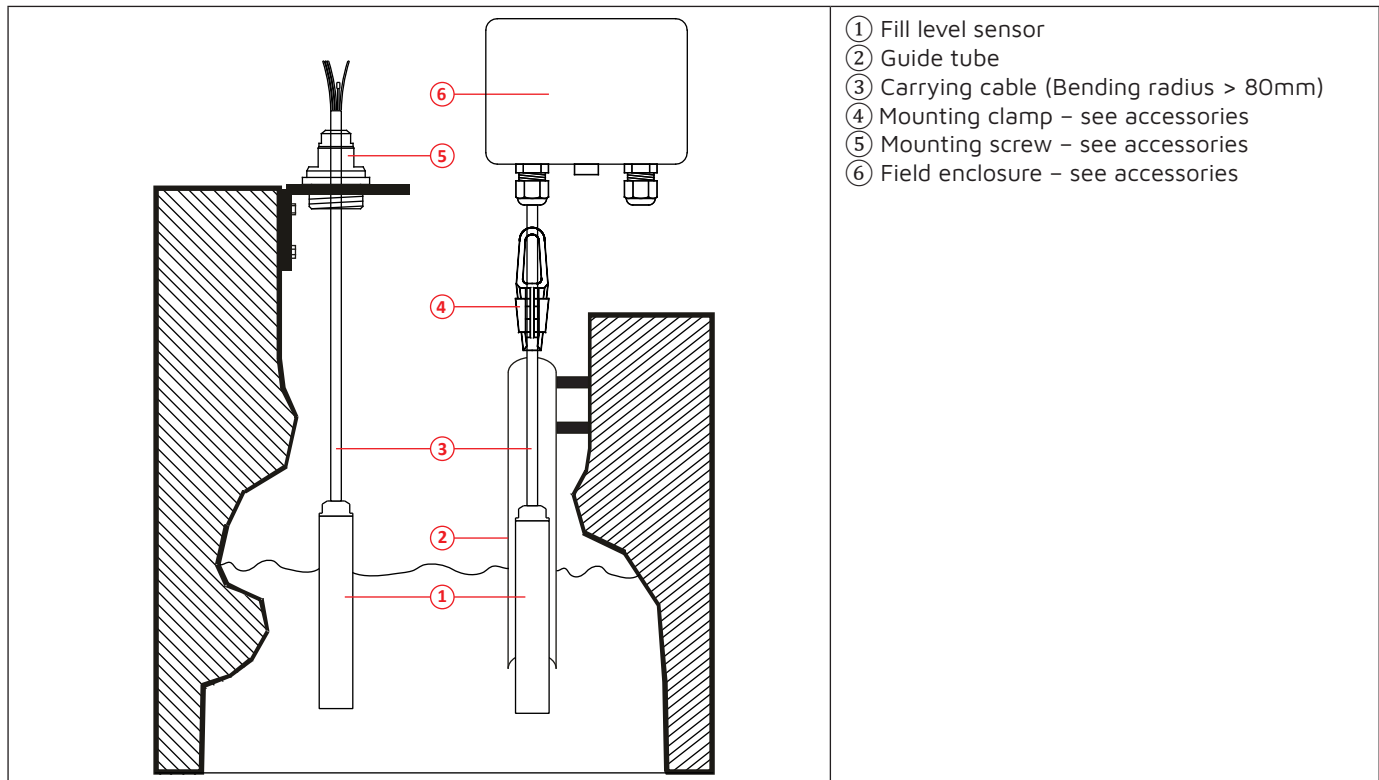

### 4.3. Installation notes

Do not remove packaging until just before mounting and check the device for any damage.

The transport protection cap, which is attached at the process connection resp. the diaphragm, must only be removed immediately before the installation. The transport protection cap must be removed. The diaphragm may not be damaged.

Pollution or damaging of the pressure compensation capillary can lead to faulty measuring results.

If the cable is shortened, the filter at the pressure compensation tube has to be reattached.

<b>WARNING</b>	Install the device only when the system is pressureless. There is a risk of fast escaping media resp. pressure blow.
<b>WARNING</b>	Let the system cool down sufficiently before installing the device. There is a risk of dangerous and hot media escaping.

## 5. Electrical connection

### 5.1. Electronic output [09-A]/[09-X] – Current 4...20mA, FSK

#### 5.1.1. Function

The digital communication protocol uses Frequency Shift Keying (FSK) technology and is superimposing onto the analogue sensor signal 4...20mA. This allows a two-way-communication and thus allows the transmission of additional information's, that going above the normal process variables, from or to an intelligent field device.

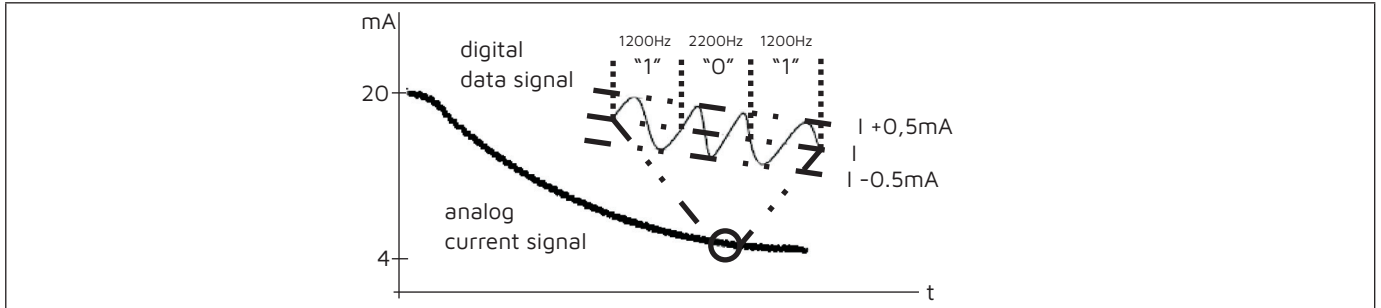

The communication protocol communicates with 1.200 Bit/s without interrupting the 4...20mA signal and thus allows the host application (master), to receive two or more digital actualizations per seconds from an intelligent field device. The digital signal does not disturb the 4...20mA.

The communication protocol offers two simultaneous communication channels: the analogue 4...20mA signal and a digital signal. The 4...20mA signal transmits the primary measuring value by the 4...20mA current loop, the fastest and most reliable industry standard. The digital signal transmits additional information's from the device like device state, diagnosis date, additional measuring values or calculated values, etc.

The combination of both principles in one installation allows a cost effective and especially robust comprehensive field communication solution, which can be simply uses and configured.

#### 5.1.2. Terminal assignment

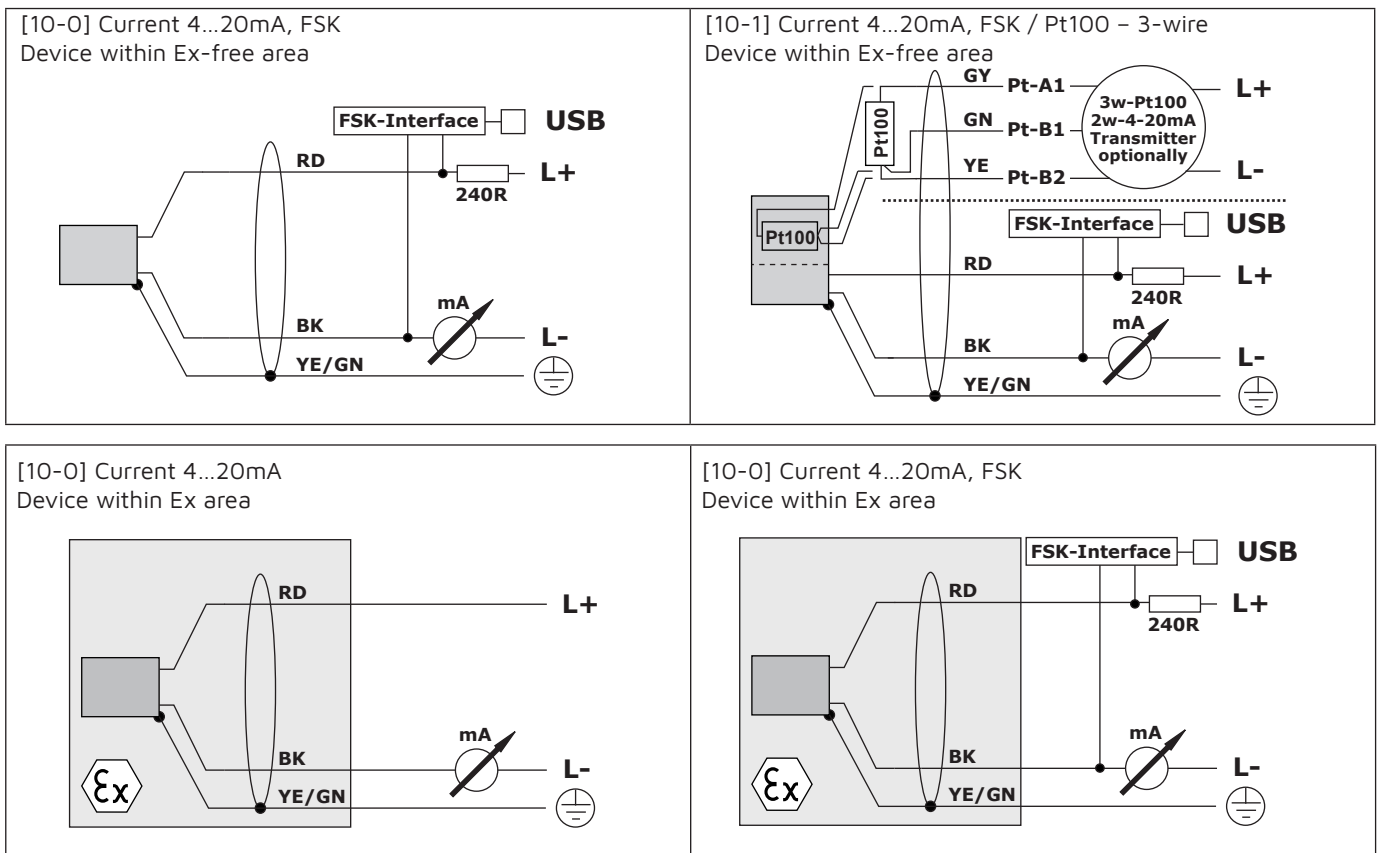

**NOTE** Consider resistor 240Ω within wire +L for connection of the FSK-communication device.

#### 5.1.3. Connection cable

Use a cable 2-core, twisted, shielded.

Cable colours: RD = red / BK = black / GY = grey / GN = green / YE = yellow / YE/GN = yellow/green

### 5.1.4. Connection notes

<b>WARNING</b>	Install the device only in de-energized state.
----------------	--

<b>NOTE</b>	For start-up deactivate all connected control devices.
-------------	--

Observe maximum permitted supply voltage  $U_s$  at the terminals L+/L-:

- $U_s = 9...35\text{VDC}$
- Ex:  $U_s = 9...30\text{VDC}$

Observe maximum permitted load resistor  $R_L$  of the analogue output:

- $R_L \leq (U_s - 9\text{V}) / 22,2\text{mA}$

The device must be grounded, preferred by the metallic process connection, alternatively by the cable shield.

Install cable separated from power leading cables.

### 5.1.5. Analogue output $I_o$

An analogue current signal is generated, that is referred to the nominal measuring range of the device:

- 4 - 20mA output signal range 3,9...20,5mA

Behaviour of the output current values at overriding the output signal range:

- Hold end value 3,9mA / 20,5mA

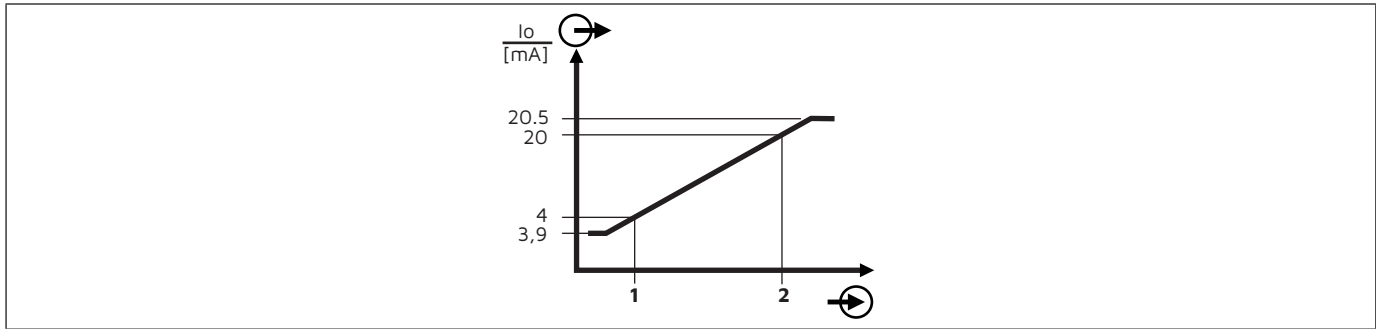

## 5.2. Electronic output [09-V] – RS485 Modbus-RTU

### 5.2.1. Function

The Modbus protocol is a communication protocol, that base on a master/slave architecture.

All devices are connected by two data wires (A+ / B-) and by one COMMON-wire (C/L-).

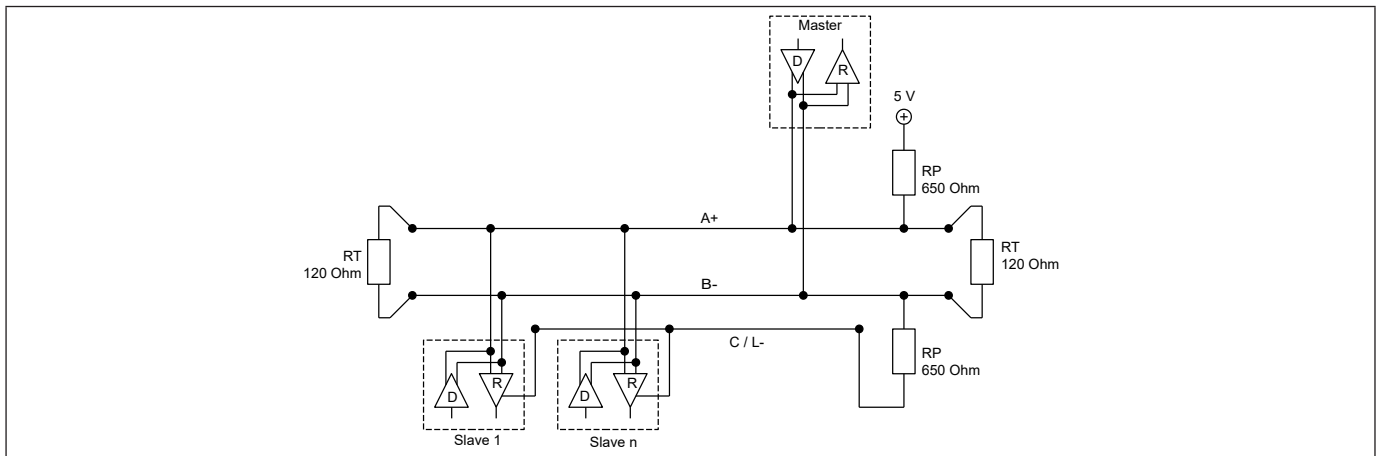

An original RS485 allows the connection of 32 slaves within one segment. The device has a load of only 1/8 of the standard load ( $R_{in} \geq 96\text{ k}\Omega$ ), thus up to 256 of the devices can be theoretically operated within one network segment. However the number is limited to 247 due to the Modbus address space.

The both termination resistors  $R_T$  prevent reflections on the data wires. The optimum resistor value depends on the wave impedance of the used cable, but a value of 120 Ohm is a popular choice.

The polarisation network is necessary, to ensure suitable potentials, if none of the devices transmits and thus the wires A+ and B- are undefined (high impedance). The value for  $R_P$  depends e.g. on bus load or the termination resistors. Recommended values are between 450 Ohm and 650 Ohm.

The use of a polarisation network is recommended, to ensure a stable network. Usually the polarisation resistors are implemented within the master device or they are connectible.

Connect the device at bus topology (line). A stub line must be avoided.

### 5.2.2. Terminal assignment

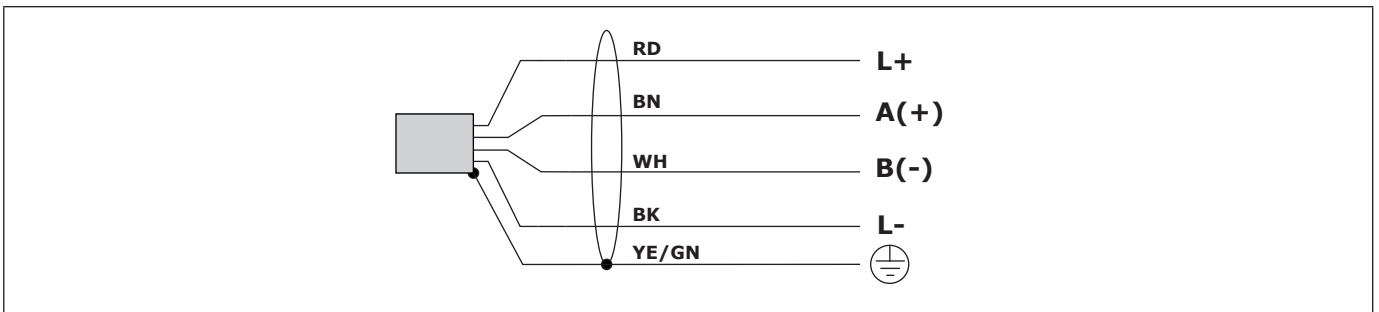

### 5.2.3. Connection cable

Use a cable 4-core acc. to the EIA485 recommendations:

Impedance	135...165Ω @ 3...20Mhz
Cable capacity	< 30pF/m
Cable diameter	> 0,64mm
Cable cross section	0,34 mm <sup>2</sup> / AWG 22
Loop resistance	< 110Ω/km
Shielding	Braided shield /shield foil
Cable length	38400 Baud ≤ 1200m

Cable colours: RD = red / BN = brown / WH = white / BK = black / YE/GN = yellow/green

### 5.2.4. Connection notes

<b>WARNICG</b>	Install the device only in de-energized state.
<b>NOTE</b>	For start-up deactivate all connected control devices, to avoid unwanted control reactions.

Observe maximum permitted supply voltage  $U_s$  at the terminals L+/L-:

- $U_s = 6...35VDC$

The device must be grounded, preferred by the metallic process connection, alternatively by the cable shield.

Install cable separated from power leading cables, if existing connect shield to earth.

## 6. Operation

### 6.1. Electronic output [09-A] – Current 4...20mA, FSK

Configuration and data transmission can be made per standard FSK interface, e.g. isHRT USB and operating software. The use of the DTM isHRT CommDTM resp. ICS Generic HART DTM is recommended.

Information's for installation resp. using the FSK interface resp. the operating software are not content of this manual.

<b>NOTE</b>	At a set damping from 0s...<1s the communication is only active for 20s after power-up the supply voltage. After establishing the connection it will be stay active. While this, the damping is set to 1s. After 4 minutes of inactivity the connection will be terminated and the damping is reset to the set value. At a set damping of $\geq 1$ s the establishing of a communication connection is always possible.
-------------	---

#### Default settings [Adjustment range]:

	Default settings	Description
Address	0 [0...15]	
Damping	1s [0s...60s]	Time till a change at the input has been processed at the output by 100%.
Start value LRV	Nominal lower adjust value = 4mA	LRV < URV Span $\geq 25\%$
End value URV	Nominal upper adjust value = 20mA	LRV < URV Span $\geq 25\%$

### 6.2. Electronic output [09-V] – RS485 Modbus-RTU

Operation is via the wired interface.

Information on installing and using the interface and operating software is not included in this manual.

#### 6.2.1. Parameter

The parameter file and description can be downloaded from the website [www.acs-controlsystem.com](http://www.acs-controlsystem.com).

Setting ranges and default values for all parameters are provided.

## 7. Error diagnosis and Troubleshooting

The operator of the system is responsible for taking suitable measures to rectify faults.

In case of malfunction check:

Component / area	Check	Rectification
Enclosure	Damage	Replace device resp. send in for repair
Pressure diaphragm	Pollution	Clean device resp. send in for repair
	Damage	Replace device resp. send in for repair
Process seal	Damage	Replace process seal
		Use other seal material if necessary
Compensation capillary	Pollution	Clean capillary resp. send device in for repair
Supply voltage	Operating voltage available	Switch-on resp. repair operating voltage
		Check terminals resp. repair
	Operating voltage reverse connected	Reverse operation voltage connection
	Operating voltage too low	Adapt resp. repair
	Operating voltage too high	Send in the device for repair
	Load resistance too high	Reduce resistance / Increase operating voltage
	Connection cable damaged	Send in device for repair

If the malfunction cannot be eliminated, please contact the manufacturer.

## 8. Maintenance

At appropriate use, the device is free of maintenance.

Solid coatings on the diaphragm or conductivity measuring cell can lead to faulty measurement results. In this case the diaphragm or conductivity measuring cell must be regularly cleaned. Don't use sharp resp. hard tools, pressured air or aggressive chemicals. For dismantling the device see chapter "Dismounting".

### 8.1. Calibration conductivity sensor

The calibration determines the cell constant of the conductivity sensor. The cell constant takes into account the geometric dimensions, materials and design of the conductivity sensor, especially the aging process of the electrodes. The recommended recalibration interval is 12 months; in difficult measuring point conditions (deposits, abrasion, chemical influences) 4 to 6 months. The calibration process is carried out in accordance with separate calibration instructions.

## 9. Repair

The device is not intended for repair by the user. A repair may only be carried out by the manufacturer.

### 9.1. Dismounting

Use suitable protective clothing, e.g. goggles, gloves.

<b>WARNING</b>	Let the device and the system cool down sufficiently fore dismantling it. There is a risk of hot surfaces as well as dangerous and hot media escaping.
----------------	--

<b>WARNING</b>	Install the device only in de-energized state.
----------------	--

<b>NOTE</b>	For start-up deactivate all connected control devices
-------------	---

After dismantling the diaphragm must be fitted with protective caps.

### 9.2. Return

Returns can only be accepted if the device has been equipped with a Decontamination declaration enclosed. The decontamination declaration is available at <https://www.acs-controlsystem.com> at the download area and must be completely filled in, and affixed securely and weather-proof to the outside of the packaging.

### 9.3. Disposal



As required by the Directive 2012/19/EU on waste electrical and electronic equipment (WEEE), products of ACS are marked with the depicted symbol in order to minimize the disposal of WEEE as unsorted municipal waste. Such products may not be disposed of as unsorted municipal waste and can be returned to ACS for disposal.

The return follows the conditions stipulated in the General Terms and Conditions or as individually agreed by ACS.

## 10. Technical Data

Reference conditions	Ta = +15°C..+25°C (+59°F..+77°F) / Pa = 860..1060kPa / r.h. = 45..75% ton = 240s / vertical, sensor downside
Messabweichung	EN/IEC 60770-1: Characteristic deviation – Limit value adjustment
Ansprechzeit	IEC 60751: water / 0,4 m/s / temperature step 10K

### 10.1. Inputs

#### 10.1.1. Input pressure/fill level [08-##]

Sensor type	Capacitive cell					
Type code	[08-01]	[08-02]	[08-03]	[08-04]	[08-05]	[08-07]
Meas. range PN, gauge, FSI	0..0,1bar	0..0,2bar	0..0,4bar	0..0,6bar	0..1 bar	0..2 bar
Overload/Burst pressure, gauge	5 bar	5 bar	6 bar	10 bar	10 bar	15 bar

Type code	[08-08]	[08-09]	[08-10]	[08-12]		
Meas. range PN, gauge, FSI	0..4 bar	0..6 bar	0..10 bar	0..20 bar		
Overload/Burst pressure, gauge	25 bar	40 bar	40 bar	40 bar		

Type code	[08-0A]	[08-0B]	[08-0C]	[08-0M]	[08-0D]	[08-0E]
Meas. range PN, gauge, FSI	0..1mWS	0..2mWS	0..4mWS	0..5mWS	0..6mWS	0..10mWS
Overload/Burst pressure, gauge	5 bar	5 bar	6 bar	10 bar	10 bar	10 bar

Type code	[08-0F]	[08-0L]	[08-0G]	[08-0J]	[08-0K]	[08-0H]
Meas. range PN, gauge, FSI	0..20mWS	0..25mWS	0..40mWS	0..50mWS	0..60mWS	0..100mW
Overload/Burst pressure, gauge	15 bar	25 bar	25 bar	40 bar	40 bar	40 bar

Resolution	FSI ≥ 16 Bit
Characteristic deviation	≤ ±0,05%FSI / ±0,1%FSI / ±0,2%FSI
Hysteresis	negligible
Reproducibility	negligible
Influence auxiliary power	≤ ±0,002%FSI/V
Influence of temperature	Tk zero ≤ ±0,015%FSI/K, ≤ ±0,75%FSI
	Tk span ≤ ±0,015%FSI/K, ≤ ±0,5%FSI (≥0,4bar/4mWS)
	Tk span ≤ ±0,8%FSI (<0,4bar/4mWS)
Influence mounting pos.	Measuring range < 1bar: ≤ 0,2mbar (Position: vertical, sensor topside)
	Measuring range ≥ 1bar: ≤ ±0,1mbar (Position: vertical, sensor topside)
Long term drift zero value	≤ ±0,15%FSI/year

#### 10.1.2. Input temperature [10-1] – Pt100, 3-wire

Sensor type	Resistor Pt100 / class B / 3-wire – IEC 60751
Measuring range – FSI	-20...+70°C (-4°F... +158F)
Time behavior	t90 ≤ 60s
Characteristic deviation	≤ ±0,3K + 0,005 * [Tp]

#### 10.1.3. Input temperature[10-3]/[10-4] – Pt1000

Sensor type	Resistor Pt1000 – IEC 60751
Measuring range – FSI	-20...+70°C (-4°F... +158F)
Resolution	≤ ±0,01K / FSI ≥ 16 Bit
Characteristic deviation	≤ ±0,2K + 0,005 * [Tp]
Long term drift	≤ ±0,1K/year

#### 10.1.4. Input conductivity [10-4]

Sensor type	conductive 4-electrode-cell
Measuring range – FSI	0...50mS/cm
Resolution	≤ 1μS/cm
Characteristic deviation	≤ ±1% of measuring value (≥ ±1μS/cm)
Temp. compensation	-2%/K / -5...+45°C (+23°F... +113°F)
Reference temperature	+25°C

### 10.2. Ausgänge

#### 10.2.1. Electronic output [09-A] – Current 4...20mA, FSK

<b>Interface - Cio</b>	
Specification	FSK / 1200 Bit/s
Communication resistor	≥ 240Ω, external
<b>Analogue output - Io</b>	
Signal range	4...20mA = Measuring range PV >> [08-##], Limit value/Error = 3,9...20,5mA
Resolution	≤ 1μA
Permitted load RL	≤ (Us - 9V) / 20,5mA
Influence uxiliary power	≤ ±0,5μA/V
Influence temperature Ta	≤ ±1μA/K
<b>Hilfsenergie</b>	
Supply voltage Us	[09-A/X]/[03-S]: 4...20mA: 9...35VDC reverse polarity protected / ≤ 2Vpp [09-A/X]/[03-X/Z]: 4...20mA Ex: 9...30VDC reverse polarity protected / ≤ 2Vpp
Input current Is	≤ 20,5mA
Ready delay time	≤ 0,1s (td = 0s)

#### 10.2.2. Electronic output [09-V] – RS485 Modbus-RTU

<b>Interface - Cio</b>	
Specification	RS485, bidirectional / Modbus-RTU / 9600 Baud (4800...38400 Baud)
Input resistance	112Ω
Time behaviour	Signal pressure/fill level: t90 ≤ 2ms (td = 0s)
	Signal temperature: t90 ≤ 60s (td = 0s)
	Signal conductivity: t90 ≤ 2s (td = 0s)
<b>Auxiliary power</b>	
Supply voltage Us	6...35VDC reverse polarity protected / Ripple voltage ≤ 2Vpp
Input current Is	≤ 10mA (without load)
	≤ 15mA (without load) >> [10-4] Temperature/Conductivity
Ready delay time	≤ 0,1s (td = 0s)
	≤ 4s (td = 0s) >> [10-4] Temperature/Conductivity

### 10.3. Environmental conditions

Process temperature T <sub>p</sub>	-20...+70°C (-4°F... +158F)
	[03-X/Z]: ATEX/IECEX: see certificate
Pressure cycles	≥ 100 Mio. (1,2xPN)
Ambient temperature T <sub>a</sub>	-20...+70°C (-4°F... +158F)
	[03-X/Z]: ATEX/IECEX: see certificate
Protection level	IP68 [≤100m/≤20bar] (EN/IEC 60529)
Climatic classification	4K4H (EN/IEC 60721-3-4)
Shock classification	50g [11ms] (EN/IEC 60068-2-27)
Vibration classification	20g [10...2000 Hz] (EN/IEC 60068-2-6)
EM compatibility	Operation device class B / Industrial range (EN/IEC 61326)
Overvoltage protection	Integrated overvoltage protection (EN/IEC 61000-4-5)
	Isolation voltage ≥ 50VDC / Rated leakage current 10kA (8/20μs)
Protection class	III
Pollution degree	4
Altitude above sea level	2000m above NN
MTTF	463,4 years
Weight	0,3kg + (L1 x 0,068kg/m)
	0,375kg + (L1 x 0,068kg/m) >> [10-4] Temperature/Conductivity

### 10.4. Materials

process wetted	Ceramic Al <sub>2</sub> O <sub>3</sub> , 99,9% Steel 1.4404/316L, Steel 1.4571/316Ti, Steel1.4462/318LN (Duplex) FKM/FPM, EPDM, PE, PUR, Epoxyd
Carrying cable	Breaking force steel core: ≥ 920N Bending radius: ≥ 80mm Cross-section strands: 0,22mm <sup>2</sup> Resistance: 900hm/km

## 11. Revision

Version	Changes
BA02.20	Original version
BA03.22	Addition <ul style="list-style-type: none"> <li>Electronic - output &gt;&gt; [09-A] 4...20mA FSK</li> </ul>
BA09.22	Chapter Operation: <ul style="list-style-type: none"> <li>Addition UnitCode table</li> </ul>
BA08.24	Addition <ul style="list-style-type: none"> <li>Electronic - Function &gt;&gt; [10-4] Temperature/Conductivity</li> </ul>
BA11.24	Chapter Accessories Change <ul style="list-style-type: none"> <li>Dimensions/Article number mounting clamp CrNi steel</li> <li>Mounting clamp steel galvanized removed</li> </ul> Chapter Technical Data Change <ul style="list-style-type: none"> <li>Material measuring cell ceramic Al<sub>2</sub>O<sub>3</sub> 99,9%</li> </ul> Addition <ul style="list-style-type: none"> <li>Reference temperature conductivity measurement +25°C</li> </ul>
BA06.25	Addition <ul style="list-style-type: none"> <li>Approval &gt;&gt; [03-X] ATEX / IECEx: II 1 G Ex ia IIC T6 Ga / II 1 D Ex ia IIIC Da</li> <li>Approval &gt;&gt; [03-Z] ATEX / IECEx: II 2 G Ex ib IIC T6 Gb / II 2 D Ex ib IIIC Db</li> <li>Approval &gt;&gt; [03-X/Z] ATEX: II 3 G Ex ec IIC Gc</li> </ul>
BA10.25	Correction safety notes operating supplies for explosive hazardous areas Correction product label Correction ATEX/IECEx product code
BA12.25	ATEX/IECEx Li/Ci values correction Category 3 removed from safety notes



---

FEEL FREE TO  
CONTACT US

ACS-CONTROL-SYSTEM GmbH  
Lauterbachstr. 57  
84307 Eggenfelden - Germany  
[info@acs-controlsystem.de](mailto:info@acs-controlsystem.de)  
[www.acs-controlsystem.com](http://www.acs-controlsystem.com)  
+49 (0) 8721-9668-0