

# Hydrolog® HLF4

Data logger with data remote transmission for water level recording  
Operating manual BA02.20



Technical modifications reserved.

## 1 Safety instructions

The operating manual is part of the device and must be kept always accessible nearest its installation location.

Installation, electrical connection, commissioning, operation, dismantling and disposal of the device must be made by a qualified and authorized expert according to the information's in this Operating Manual and the relevant standards and rules.

This expert must have read and understood this Operating Manual and especially the safety notes. Complementary the Technical Information TI has to be adhered to, that can be ordered by the manufacturer or downloaded from the homepage.

### 1.1 Operational safety

The device is safely built and tested according to state-of-the-art technology.

The device meets the legal requirements of all relevant EU directives. This is confirmed by attaching the CE mark. The associated EU-Declaration of Conformity can be ordered or downloaded from the homepage.

### 1.2 Intended use

The device is an electronic data logger with integrated data remote transmission 4G/2G, for autonomous recording of different measurands.

The device may only be used within the permitted operation limits. Every use besides these limits as agreed can lead to serious dangers.

The materials of the device must be checked for compatibility with the respective application requirements (contacting materials, process temperature) before use, otherwise this can lead to abnormal behavior, damage or destruction of the device and to the resulting dangers.

The sensors may not be used as sole device for prevention of dangerous conditions in machines and plants.

The device may not be used in areas where the using of mobile phones is not allowed, e.g. in hospitals or explosive hazardous areas.

Electromagnetically sensitive devices can be interfered in their operation because of the high energetic radio waves at the moment of data transmission.

The operational reliability of the device is ensured only at the intended use.

An inappropriately use, disregarding the Operating Manual and the technical rules, using under-qualified personnel, making unauthorized alterations as well as damage of the device releases the manufacturer from liability for any resulting damage. This renders the manufacturer's warranty null and void.

ACS-CONTROL-SYSTEM GmbH  
Lauterbachstr. 57  
D- 84307 Eggenfelden

Tel.: +49 (0) 8721/ 9668-0  
Fax: +49 (0) 8721/ 9668-30

## 2 Installation

### 2.1 Product label

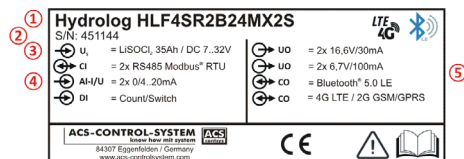

- ① Type code
- ② Serial number
- ③ Power supply
- ④ Input signals
- ⑤ Output signals

### 2.2 Installation place

The correct function of the device within the specific technical data can only be guaranteed, if the permitted process and environmental conditions at the installation place (see Technical Information TI) will not be exceeded.

Before installation the signal strength of the mobile network must be checked (eventually see mobile display). At insufficient mobile network strength a data transmission can be impossible and there will be exhausted essentially more battery capacity. This will considerably reduce the run time of the device. Eventually another installation place must be chosen.

By use of an optimal mounted external antenna or eventually a directional antenna the signal strength can be substantially increased.

### 2.3 Installation notes

Do not remove packaging until just before mounting and check the device for any damage.

The device can be inserted directly into a filler cap for water level tubes 2". The installation into wider filler caps is done by adapter plates.

The construction of the device allows damage protected flooding up to 3m water column.

**Note** - For connection of hydrostatic filling level sensors with reference air compensation an air pressure compensation element is installed at the bottom side. This may not be damaged or polluted, otherwise this can lead to abnormal behavior, damage or destruction of the device and to the resulting dangers.

**Note** - At very cold temperatures rising moisture can lead to strong icing at the bottom side of the device and thus to a sealing of the pressure compensation element. This can be reduced substantially by installing a breathable foam part into the water level tube.

**Note** - Before inserting the device into the water level tube check if all cable glands, the enclosure tube and the antenna plug are tightly screwed.

## 3 Electrical connection

**Danger** – Install the device only when power supply is off. There is a risk of electric shock.

**Note** - When opening the device avoid the pollution of the internal area of the device with humidity or dirt, otherwise this can lead to abnormal behavior, damage or destruction of the device and to the resulting dangers.

The enclosure tube must be released by the closing screw at the lower end of the device and can then be pulled off.

**Note** - The cable of the connected sensor is fixed by the cable gland. To prevent safely a slip down, fix e.g. a cable core, the cable shielding braid or also unused stranded wires into the double screw blocks laterally positioned to the 5pole terminal block.

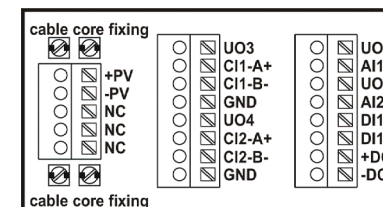

The terminals are suitable for connection of:

Single-wire / Fine-wire conductor	0,2...1,5mm <sup>2</sup>
Fine-wire conductor with ferrule	0,25...1,0mm <sup>2</sup>
Stripping length	8,5...9,5mm
Clamping range cable gland	2x 4...8mm / 1x 3,5...5mm

After the battery change the enclosure tube must be pushed on till to the stop and closed completely by the closing crew.

**Note** - The configuration of the inputs and output contributes significantly to the energy consumption of the device. An unfavourable configuration can reduce the runtime, especially at a device with battery.

### 3.1 Supply

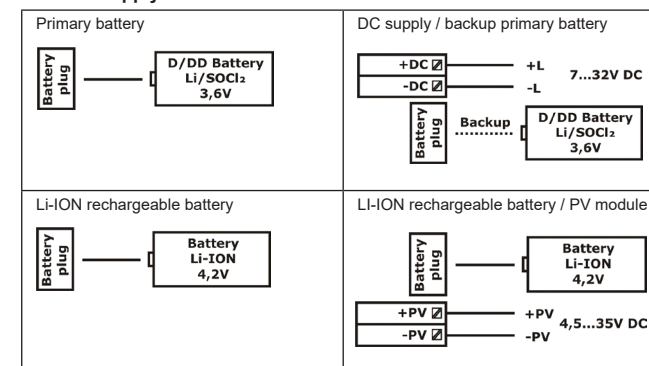

**ACS-CONTROL-SYSTEM**  
knowhow with system

Your partner for measuring technology and automation



info@acs-controlsystem.de  
www.acs-controlsystem.de

The plug of the connection cable to the battery can be only pulled off after releasing the locking lever at the plug jack.

**Danger** – Only suitable batteries may be used, otherwise this can lead to abnormal behavior, damage or destruction of the device and to the resulting dangers.

**Danger** – The primary battery may not be charged. There is explosion or fire hazard.

Charging the rechargeable battery can be made:

- Internal devices by a connected suitable PV module.
- External devices by a suitable DC power supply.

### 3.2 Input analogue – AI1/AI2

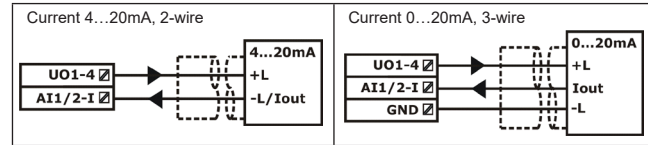

A suitable sensor power supply must be configured or provided externally.

### 3.3 Input communication – CI1/CI2 – RS485 Modbus®-RTU

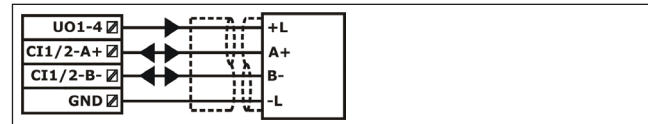

A suitable sensor power supply must be configured or provided externally.

### 3.4 Input digital – DI1

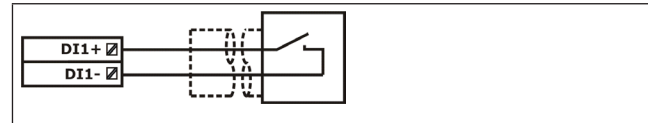

**Notes** - The input can be configured as control input (e.g. a float switch) as well as impulse counter (e.g. a flow meter)

### 3.5 Output analogue – UO1...UO4

UO1 / UO2	16,6V / 0...30mA
UO3 / UO4	6,7V / 0...100mA

The outputs UO1...UO4 are used for temporally limited sensor supply.

## 4 Operation

**Note** – The operation device must be equipped with Bluetooth® version 4.1 and higher, recommended is version 4.2 and higher.

The configuration is made per mobile app ACS-SmartConnect, which must be loaded and installed from app stores.

An activated communication connection is signaled internally the device by cyclic flashing of an LED.

**Note** - An unfavourable installation position reduces substantially the possible reach of the radio communication to the operation device.

**Note** - The configuration of the device contributes significantly to the energy consumption of the device. An unfavourable configuration can reduce the runtime, especially at a device with battery.

The most important factors for the runtime of the device are:

- Frequency of the mobile communication
- Quality of the mobile network
- Frequency of measuring value logging
- Supply current of the sensors
- On-time of the sensors

**Notes** – In the case of a fail function, the device can be reset by an internal RESET pushbutton. The successful restart is signaled by a double flash of an LED.

## 5 Maintenance

For dismantling the device see chapter "Dismounting".

For battery change see chapter "Electrical connection" – section "Supply".

## 6 Dismounting

Use suitable protective clothing, e.g. goggles, gloves.

**Danger** - Dismount the device only when power supply is off. There is a risk of electric shock.

**Danger** - Let the device and the system cool down sufficiently fore dismantling it. There is a risk of hot surfaces as well as dangerous and hot media escaping.

## 7 Troubleshooting / Repair

In case of malfunction check:

- Enclosure >> Damage
- Pressure compensation opening >> Pollution / Damage
- Battery >> low charging stand / Contact / Damage
- Supply voltage >> Polarity / Voltage / Load / Contact
- Cable >> Short circuit / Wire break / Damage
- Antenna >> Contact / Damage

For dismantling the device see chapter "Dismounting".

A repair may only be carried out by the manufacturer.

## 8 Return

Enclose necessary information's for return:

- An exact description of the application.
- The chemical and physical characteristics of the product.
- A short description of the occurred error.

Before returning the device, the following measures must be performed:

- Adhesive product residues e.g. caustic, toxic, radioactive etc. must be removed.
- A returning must be refrained, if it is not possible by 100% to remove the unhealthy product completely.

## 9 Disposal

This instrument is not subject to the WEEE directive and the respective national laws. Hence, pass the instrument directly on to a specialized recycling company and do not use the municipal collecting points.