

OPERATING MANUAL - BA06.25

Precont PU4SC

Electronic pressure transmitter
with capacitive ceramic pressure measuring sensor



Index	
1. About this document	4
1.1. Dokument function	4
1.2. Terms	4
1.3. Other documents	4
2. Safety instructions	5
2.1. Authorized personnel	5
2.2. Appropriate use	5
2.3. Operational safety	5
2.4. Operating supplies for explosive hazardous areas	5
3. Product description	7
3.1. Function	7
3.2. Construction	7
3.3. Product label	8
3.4. Product code	8
3.5. Dimensions	9
3.5.1. Electrical connection	9
3.5.2. Internal process membrane	10
3.5.3. Front-flush process membrane	12
3.6. Packaging, transport, storage	16
3.7. Accessories	16
4. Installation	17
4.1. Ambient and process conditions	17
4.2. Installation place	17
4.3. Installation notes	17
5. Electrical connection	18
5.1. Electronic output [09-A] – Current 4...20mA, FSK	18
5.1.1. Function	18
5.1.2. Terminal assignment	18
5.1.3. Connection cable	19
5.1.4. Connection notes	19
5.1.5. Analogue output I _o	19
5.2. Electronic output [09-B] – Voltage 0...10V	19
5.2.1. Function	19
5.2.2. Terminal assignment	19
5.2.3. Connection cable	19
5.2.4. Connection notes	20
5.2.5. Analogue output U _o	20
5.3. Electronic output [09-V] – RS485 Modbus-RTU	20
5.3.1. Function	20
5.3.2. Terminal assignment	21
5.3.3. Connection cable	21
5.3.4. Connection notes	21
5.4. Electronic Output [09-L] – IO-Link	21
5.4.1. Function	21
5.4.2. Terminal assignment	22
5.4.3. Connection cable	22
5.4.4. Connection notes	22
6. Operation	23
6.1. Electronic output [09-A] – Current 4...20mA, FSK	23
6.2. Electronic output [09-B] – Voltage 0...10V	23
6.3. Electronic output [09-V] – RS485 Modbus-RTU	24
6.3.1. Parameter	24
6.4. Electronic output [09-L] – IO-Link	24
6.4.1. Parameter	24
6.4.2. Switch output S _o	24
6.4.3. Analogue output I _o	26
7. Error diagnosis and Troubleshooting	27
8. Maintenance	27
9. Repair	28
9.1. Dismounting	28
9.2. Return	28
9.3. Disposal	28

10. Technical Data	28
10.1. Input.....	28
10.1.1. Input pressure	28
10.1.2. Input pressure - Gauge pressure [12-R].....	29
10.1.3. Input pressure - Absolute pressure [12-A].....	30
10.2. Electronic output [09-A] - Current 4...20mA, FSK.....	30
10.3. Electronic output [09-B] - Voltage 0...10V	31
10.4. Electronic output [09-V] - RS485 Modbus-RTU.....	31
10.5. Electronic output [09-L] - IO-Link	31
10.6. Environmental conditions.....	32
10.7. Materials.....	32
11. Revision	32

1. About this document

1.1. Dokument function

These instructions for use describe the structure, functions and the use of the product and will help to operate the product as intended.

Read these instructions carefully before using the product. This is to avoid possible damage to persons, property or the device.

The Operating manual is part of the device and must be kept always accessible nearest its installation location.

All statements within this document correspond to the information available at the time of printing. Subject to change without prior notice.

1.2. Terms

NOTE	Notes to prevent failures, malfunctions, damage to devices or plants.
-------------	---

WARNING	Non-observance of the information may result in serious or fatal personal injury.
----------------	---

[04-5]	Exemplary notice to a type variant (>> chapter Product description - Product code)
---------------	--

1.3. Other documents

Besides this document the following material can be found on the Internet at www.acs-controlsystem.com:

- EU Declaration of Conformity (current version)
- Manufacturer declarations
- Certificates
- Parameter lists
- 3D-CAD models

2. Safety instructions

2.1. Authorized personnel

Installation, electrical connection, commissioning, operation, maintenance, dismantling and disposal of the device must be made by a qualified and authorized specialist according to the information's in the Operating manual and the applicable standards and rules.

This specialist must have read and understood the Operating manual and particular the safety instructions. During work on and with the device, the required personal protective equipment must always be worn.

If the device is intended for use in explosion-hazardous areas, the safety instructions for electrical apparatus for explosion-hazardous areas must be observed in particular.

2.2. Appropriate use

The device is an electronic pressure sensor for monitoring, regulating and continuously measuring pressures in gases, vapors, liquids and dusts.

The operational reliability of the device is only guaranteed when used as intended. Inappropriate or incorrect use of this product can give risk to application specific hazards, e.g. vessel overflow through incorrect installation or setting. Damage to property and persons or environmental contamination can result. Also, the characteristics of the instrument can be impaired.

Improper use, disregarding the Operating manual and the technical rules, using insufficiently qualified personnel, unauthorized modifications and damage of the device exclude the manufacturer from liability for any resulting damage. The manufacturer's warranty becomes void.

2.3. Operational safety

The device is safely built and tested according to state-of-the-art technology. The instrument may only be operated in a technically flawless and reliable condition. The operator is responsible for the trouble-free operation of the instrument. The device may only be used within the permitted operation limits. Any use outside of these intended limits can lead to serious dangers.

The materials of the device must be checked for compatibility with the respective application requirements before use. An unsuitable material can lead to damage, malfunction or destruction of the device and to the resulting dangers.

The device may not be used as sole device for prevention of dangerous conditions in machines and systems.

For safety and warranty reasons, any invasive work on the device beyond that described in the Operating manual may be carried out only by personnel authorized by the manufacturer. Arbitrary conversions or modifications are explicitly prohibited. For safety reasons, only the accessory specified by the manufacturer must be used.

This device complies with article 4 (3) of the EU directive 2014/68/EU (Pressure Equipment Directive) and is designed and produced in good engineering practice.

The device meets the legal requirements of all relevant EU directives. This is confirmed by attaching the CE mark to the device. The associated EU declaration of conformity can be requested or downloaded from the homepage.

2.4. Operating supplies for explosive hazardous areas

The electronic output version [09-A] - current 4...20mA, FSK interface, 2-wire is suitable for use in explosive hazardous areas.

If a device is installed and operated in explosive hazardous areas, the general Ex construction standards (EN/IEC 60079-14, VDE 0165), this operating manual as well as the EU type examination certificate resp. the IECEx certificate of conformity incl. supplements must be observed.

The installation of explosive hazardous systems must be carried out by specialist staff.

The devices are conceived for measuring of pressures in explosive hazardous areas.

The measured medium may also be combustible liquids, gases, fogs or vapors.

Permitted maximum values of the intrinsically safe circuits:

Voltage	Ui	30 V
Current	Ii	300 mA
Power	Pi	900 mW
Effective internal capacitance	Ci	negligible small
Effective internal inductivity	Li	5 µH

The intrinsically safe signal and supply circuit is safely galvanically isolated from parts that can be earthed.

CATEGORY 1

The device can be mounted in explosive hazardous areas, where devices of category 1 are required.

Devices of category 1 may be operated in hazardous explosive areas that require apparatus of category 1 only if atmospheric conditions are present (temperatures see tables below, pressure from 0,8 bar to 1,1 bar).

If the device is operated beyond these atmospheric conditions, the EU type examination certificate resp. the IECEx certificate of conformity can be used as a guide.

Additional tests for the special application conditions are recommended.

Devices of category 1 must be connected to intrinsically safe circuits of protection level ia.

CATEGORY 2

The device can be mounted in explosive hazardous areas, where devices of category 2 are required.

Devices of category 2 can be connected to intrinsically safe circuits of protection level ib.

For applications that require EPL Ga or Gb equipment, the following values apply:

(ATEX) / IECEx - Marking	Ambient temperature range at the electronic enclosure Tamb	Maximum surface temperature at the sensor Tmax
(II 1 G) Ex ia IIC T6 Ga (II 2 G) Ex ib IIC T6 Gb	-40°C...+42°C	T _M (Medium temperature) + 19K The special requirements for installation and operation must be observed.
(II 1 G) Ex ia IIC T5 Ga (II 2 G) Ex ib IIC T5 Gb	-40°C...+57°C	
(II 1 G) Ex ia IIC T4 Ga (II 2 G) Ex ib IIC T4 Gb	-40°C...+92°C	
(II 1 G) Ex ia IIC T3...T1 Ga (II 2 G) Ex ib IIC T3...T1 Gb	-40°C...+97°C	

For applications that require EPL Da or Db equipment, the following values apply:

(ATEX) / IECEx - Marking	Ambient temperature range at the electronic enclosure Tamb	Maximum surface temperature at the sensor Tmax
(II 1 D) Ex ia IIIC T80°C Da (II 2 D) Ex ib IIIC T80°C Db	-40°C...+42°C	T _M (Medium temperature) + 19K The special requirements for installation and operation must be observed.
(II 1 D) Ex ia IIIC T95°C Da (II 2 D) Ex ib IIIC T95°C Db	-40°C...+57°C	
(II 1 D) Ex ia IIIC T130°C Da (II 2 D) Ex ib IIIC T130°C Db	-40°C...+92°C	
(II 1 D) Ex ia IIIC T195°C Da (II 2 D) Ex ib IIIC T195°C Db	-40°C...+97°C	

A reverse heat flow from the process exceeding the permissible ambient temperature of the transmitter is not allowed and shall be avoided by a suitable thermal insulation or a suitable temperature decoupler.

CATEGORY 3

The device can be mounted in explosive hazardous areas, where devices of category 3 are required.

The device has a device protection due to increased safety (ec).

The maximum supply voltage is 30 V.

If the device has been used once in accordance with category 3 (ec – increased safety) without intrinsically safe supply, it may not more be used in accordance with category 1 or 2 (i – intrinsically safe).

When used in Zone 2, the connection cable must not be disconnected when live, in accordance with the warning on the device.

For applications that require EPL Gc equipment, the following values apply:

ATEX – Marking	Ambient temperature range at the electronic enclosure Tamb	Maximum surface temperature at the sensor Tmax
II 3 G Ex ec IIC T6 Gc	-40°C...+42°C	T _M (Medium temperature) + 19K The special requirements for installation and operation must be observed.
II 3 G Ex ec IIC T5 Gc	-40°C...+57°C	
II 3 G Ex ec IIC T4 Gc	-40°C...+92°C	
II 3 G Ex ec IIC T3...T1 Gc	-40°C...+97°C	

3. Product description

3.1. Function

The device is an electronic pressure sensor for monitoring, control and continuous measurement of pressures in gases, vapors, liquids and dusts.

A high variety of versions of process connections and electronic types allows the use for a wide range of applications, also for demanding measuring requirements.

Due to its high accuracy and the digital adjustability by FSK, RS485 Modbus®-RTU or IO-Link® the device can be suited to a wide variety of applications.

The front-flush process connection enables the cleanability of the wetted diaphragm to be integrated into the process, also by CIP/SIP cleaning processes. Low-maintenance and trouble-free pressure measurement is thus also guaranteed in critical applications with viscose or also frequently changing media.

The high precise, long term stable and robust capacitive ceramic measuring cell ensures reliable precise measuring values and allows the operation also at demanding environmental conditions, e.g. low temperatures, high shock and vibration loads or at problematic media.

The device series is available with various measuring cells for optimal adaptation to the application:

Type	Diaphragm (C)eramic / (M)etal	Internal Diaphragm	Flush-mounted diaphragm	Dry transmission	Oil-filled transmission	Sensor (C)apacitive / (S)train gauge	Without sensor seal	Sensor seal elastomer	Pressure variant (G)auge / (A)bsolute	Process pressure Low pressure	Process pressure High pressure	Process temperature	Measurement accuracy	Measurement accuracy Xcellence	IP protection	ATEX/IECEX	Food	Hydrogen
PU4SE	C	•		•		S		•	G	+	+	+	+		++			
PU4SK	C	•	•	•		S		•	G/A	++	++	++	+	•	++	•		
PU4SC	C	•	•	•		C		•	G/A	++	0	++	++	•	++	•		
PU4SM	M	•	•	•	•	S	•	•	G/A	+	++	++	+	•	++	•		
PU4LM	M		•		•	S		•	G/A	++	0	++	+	•	++	•	•	
PU4WH	M	•		•		S	•		G	0	++	0	0		++	•		•

3.2. Construction

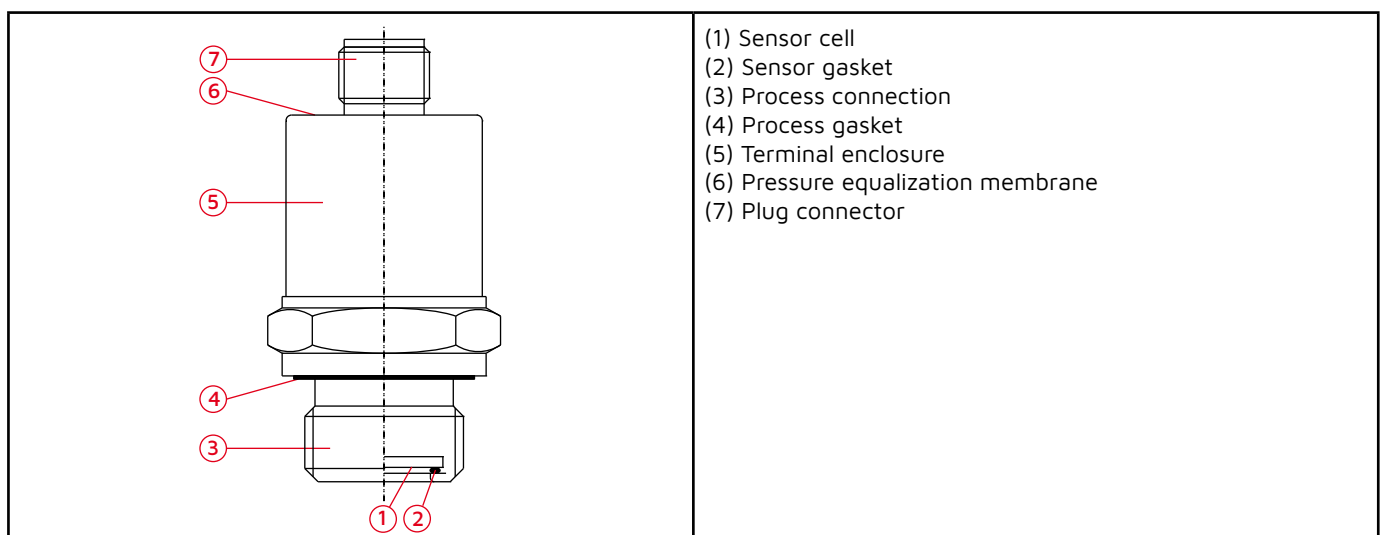

The device is installed into the plant by the process connection (3). Depending on the type, the process connection is sealed against the process by a suitable elastomer seal (4) or without elastomer.

The process pressure acts directly (dry system) via the process membrane (1) on the capacitor attached to the rear and causes a change in capacitance, which is detected by the electronics integrated in the terminal enclosure (5), processed according to the settings and output on the plug connector (7).

The process membrane is sealed to the process connection by the elastomer measuring cell seal (2).

The device has a pressure equalization membrane (6) to compensate for changes in air pressure.

Parameterization and operation of the integrated evaluation electronic can be made by the wired interface.

A laser marking of the product label ensures the identifiability of the device throughout the entire lifetime.

3.3. Product label

The product label contains the most important data for identification and use of the instrument.

①	PU4SCX31VC05AS0R4S	CE 0408	⑤	⚠	⑥	(1) Product code
②	S/N: 482569/2024		④	📖		(2) Serial number
	Us = 9..30VDC	Ex				(3) Technical data
	pi = 0..1bar	TUV 17 ATEX 212257 X - 00 / 2024				(4) Assignment
③	Io = 4..20mA	IECEx TUN 18.0002X / 2024				(5) Approvals
	1 = L+	II 1 G Ex ia IIC TX Ga				(6) Safety notes
	2 = nc	II 1 D Ex ia IIIC Txx°C Da				(7) Ignition protection type
	3 = L-/lo					
	4 = nc					
	 84307 Eggenfelden / Germany www.acs-controlsystem.com					

3.4. Product code

PU4 [01][02][03][04][05][06][07][08][09][10][11][12][13][14][94][95][96][97][98]

01	Application type	S	Standard
02	Sensor	C	capacitive, ceramic Al2O3
03	Approval	S	Standard
03		X	ATEX/IECEx: II 1 G Ex ia IIC T6 Ga / II 1 D Ex ia IIIC Da - [09-A]/[14-S]
04	Process connection	3	Thread ISO 228-1 - G¼"A, ISO 1179-2 E
04		6	Thread ISO 228-1 - G¼"A, EN 837 (Manometer)
04		4	Thread ISO 228-1 - G¼"I, internal thread
04		9	Thread ISO 228-1 - G½"A, front-flush
04		1	Thread ISO 228-1 - G½"A, EN 837 (Manometer)
04		2	Thread ISO 228-1 - G½"A, ISO 1179-2 E, internal drill
04		8	Thread ISO 228-1 - G¾"A, ISO 1179-2 E, front-flush
04		5	Thread ISO 228-1 - G1"A, ISO 1179-2 E, front-flush
04		7	Thread ISO 228-1 - G1½"B, front-flush
04		E	Thread ANSI - NPT ¼"
04		C	Thread ANSI - NPT ½"
04		R	Diary coupling DIN 11851 - DN25
04		N	Diary coupling DIN 11851 - DN40
04		M	Diary coupling DIN 11851 - DN50
04		P	Varivent N - DN40...162 (1½"...6"), Ø 68mm
04		L	DRD - DN50, Ø 65mm
04		U	Clamp DIN 32676-A - DN20
04		S	Clamp DIN 32676-A/-C - DN25...40/1"...1½", ISO 2852 - DN25...38
04		T	Clamp DIN 32676-A/-C - DN50/2", ISO 2852 - DN40...51
05	Material process seal	1	FKM/FPM
05		3	EPDM, FDA listed
05		4	FFKM
05		6	FFKM, high density
06	Material process connection	V	Steel 316L/316Ti
07	Terminal enclosure	C	U41, steel 316L
08	Measuring range	26	0...50 mbar
08		01	0...100 mbar
08		02	0...200 mbar
08		03	0...400 mbar
08		04	0...600 mbar
08		05	0...1 bar
08		06	0...1,6 bar
08		07	0...2,5 bar
08		08	0...4 bar
08		09	0...6 bar
08		10	0...10 bar
08		11	0...16 bar
08		12	0...20 bar
08		13	0...40 bar
08		19	0...100 bar
08		14	0...60 bar
08		15	-100...0 mbar
08		16	-1...0 bar
08		17	-1...+1 bar
08		18	-100...+100 mbar

09	Electronic - Output	A	Current 4...20mA, FSK interface, 2-wire
09		B	Voltage 0...10V, 3-wire - [14-C/A]
09		V	RS485 Modbus-RTU, 4-wire - [14-S]
09		L	IO-Link, current 0/4...20mA / 2x Sout PP, 4-wire - [14-S]
10	Electronic - Function	S	Standard
11	Process temperature	O	-40°C...+100°C
11		1	-40°C...+125°C
12	Pressure type	R	Gauge pressure
12		A	Absolute pressure
13	Measuring accuracy	1	0,2%
13		3	0,1%, linearization protocol
13		6	Xcellence: $\leq \pm 0,05\%$, linearization protocol
14	Electrical connection	S	Plug M12-A-4P
14		C	Plug EN 175-301-803-C (DIN 43650-C)
14		A	Plug EN 175-301-803-A (DIN 43650-A)

94	Additional option	-SF	LABS-free, silicone-free / paint compatible version
95	Additional option	-ML	Measurement point designation / TAG - Laser marking
96	Additional option	-MZ	Material test certificate - EN10204 3.1
97	Additional option	-WT	Factory certification - drink water suitability
98	Additional option	-KF	Configuration / Preset

Differing versions are normally marked by the character Y at the product code.

3.5. Dimensions

Dimensions in mm

3.5.1. Electrical connection

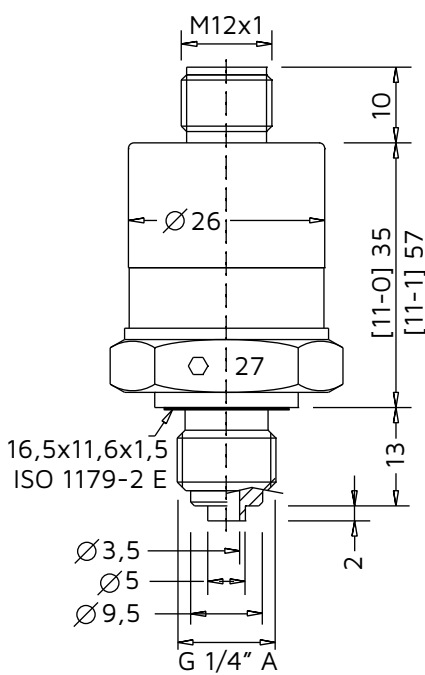
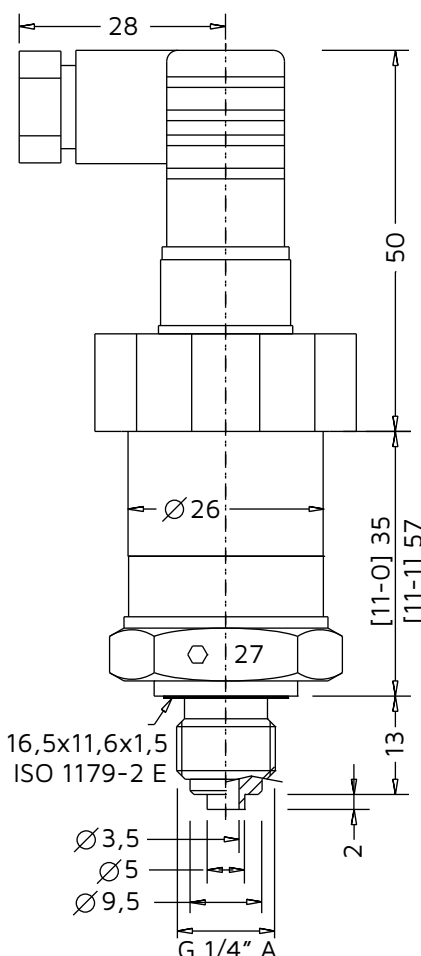
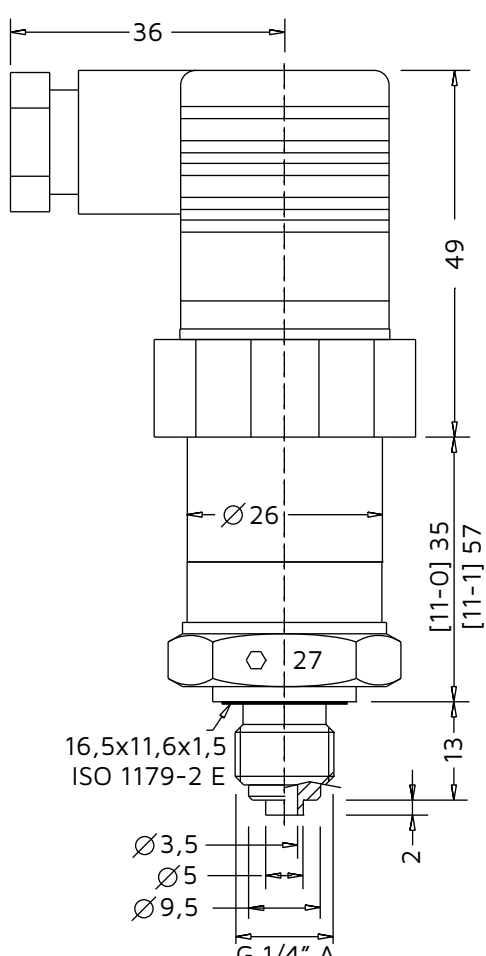
Plug M12 [14-S]	Plug EN 175-301-803-C [14-C]	Plug EN 175-301-803-A [14-A]
		

3.5.2. Internal process membrane

Thread ISO 228-1 - G1/4", EN 837 [04-6]	Thread ISO 228-1 - G1/2", EN 837 [04-1]
Process pressure P _{max} = 100 bar Torque M _{max} = 50Nm	Process pressure P _{max} = 100 bar Torque M _{max} = 50Nm

Thread ISO 228-1 - G1/4", ISO 1179-2 E [04-3]	Thread ISO 228-1 - G1/4" I, internal thread [04-4]
Process pressure P _{max} = 100 bar Torque M _{max} = 50Nm	Process pressure P _{max} = 100 bar Torque M _{max} = 50Nm

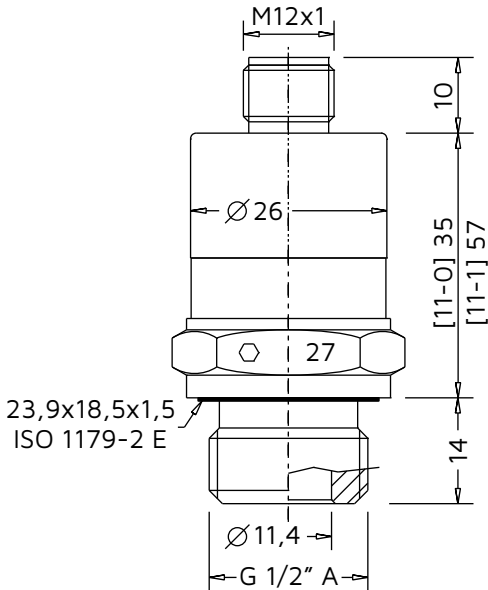
Thread ISO 228-1 - G1/2", internal drill [04-2]	
Process pressure $P_{max} = 100 \text{ bar}$ Torque $M_{max} = 50 \text{ Nm}$	
	

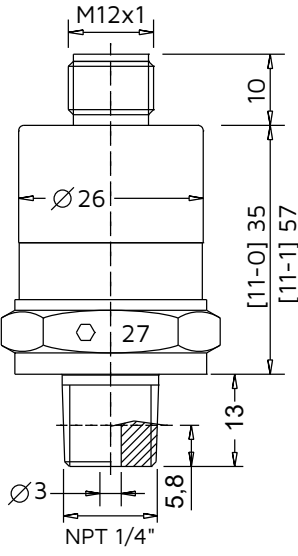
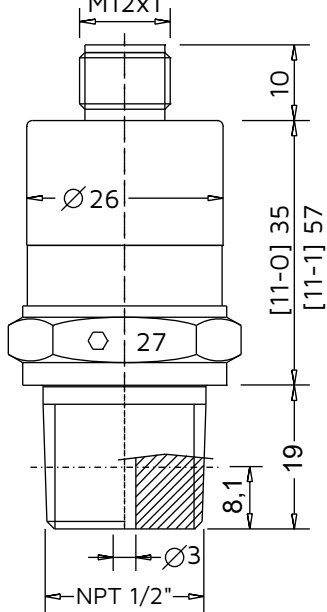
Thread ANSI - NPT 1/4" [04-E]	Thread ANSI - NPT 1/2" [04-C]
Process pressure $P_{max} = 100 \text{ bar}$ Torque $M_{max} = 50 \text{ Nm}$	Process pressure $P_{max} = 100 \text{ bar}$ Torque $M_{max} = 50 \text{ Nm}$
	

3.5.3. Front-flush process membrane

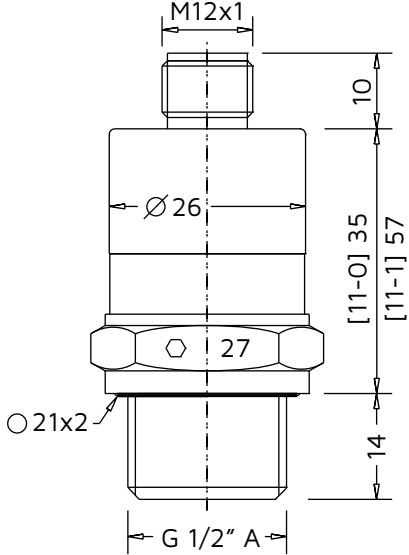
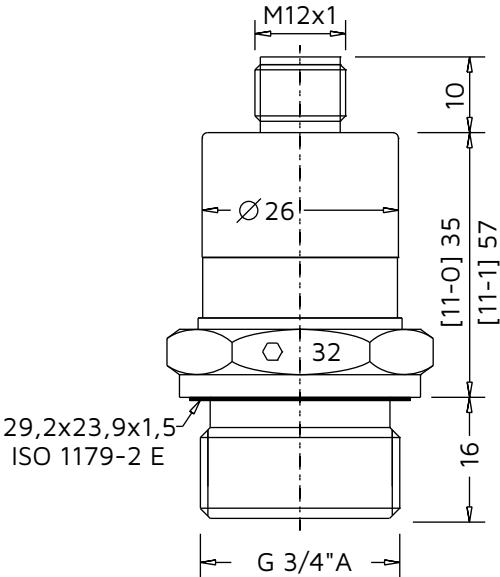
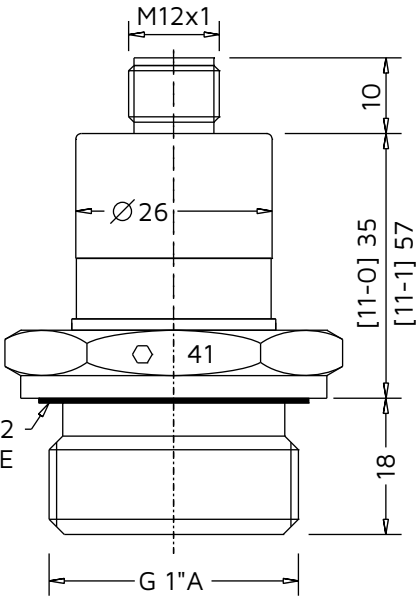
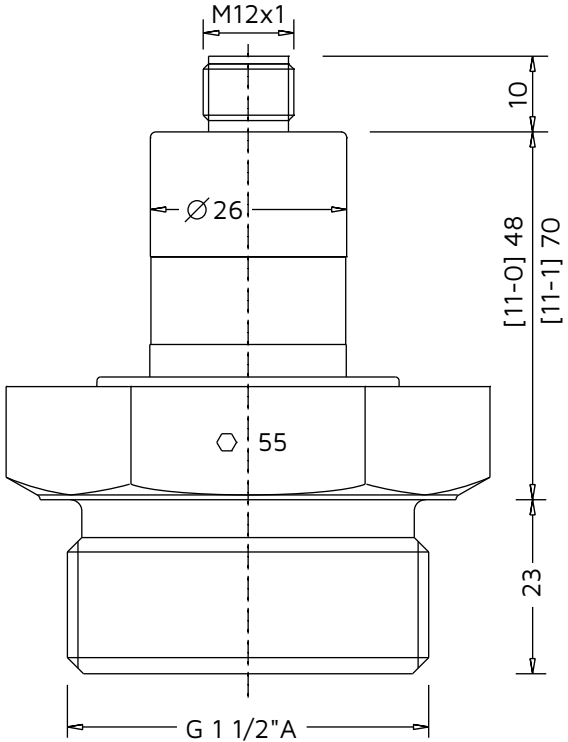
Thread ISO 228-1 - G1/2" [04-9]	Thread ISO 228-1 - G3/4", ISO 1179-2 E [04-8]
Process pressure P _{max} = 20 bar Torque M _{max} = 20Nm	Process pressure P _{max} = 100 bar Torque M _{max} = 50Nm
 <p> $M12 \times 1$ $\varnothing 26$ $[11-0] 35$ $[11-1] 57$ 10 14 $G 1/2" A$ 27 $\varnothing 21 \times 2$ </p>	 <p> $M12 \times 1$ $\varnothing 26$ $[11-0] 35$ $[11-1] 57$ 10 16 $G 3/4" A$ 32 $29,2 \times 23,9 \times 1,5$ ISO 1179-2 E </p>
Thread ISO 228-1 - G1", ISO 1179-2 E [04-5]	Thread ISO 228-1 - G1 1/2" [04-7]
Process pressure P _{max} = 100 bar Torque M _{max} = 50Nm	Process pressure P _{max} = 40 bar Torque M _{max} = 50Nm
 <p> $M12 \times 1$ $\varnothing 26$ $[11-0] 35$ $[11-1] 57$ 10 18 $G 1" A$ 41 $35,7 \times 29,7 \times 2$ ISO 1179-2 E </p>	 <p> $M12 \times 1$ $\varnothing 26$ $[11-0] 48$ $[11-1] 70$ 10 23 $G 1 1/2" A$ 55 </p>

Diary coupling DIN 11851 DN25, PN40 [04-R]	Diary coupling DIN 11851 DN40, PN40 [04-N]
Process pressure $P_{max} = 40$ bar	Process pressure $P_{max} = 40$ bar

Diary coupling DIN 11851 DN50, PN25 [04-M]
Process pressure $P_{max} = 25$ bar

Varivent N - DN40-162 (1½"-6"), Ø 68mm, PN40 [04-P]

Process pressure Pmax = 40 bar

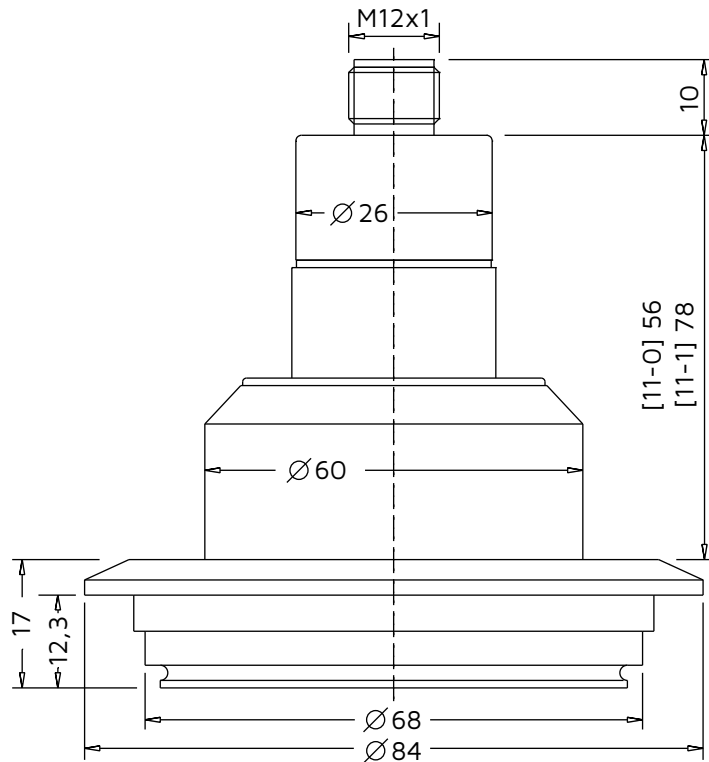

DRD - DN50, Ø 65mm, PN25 [04-L]

Process pressure Pmax = 25 bar

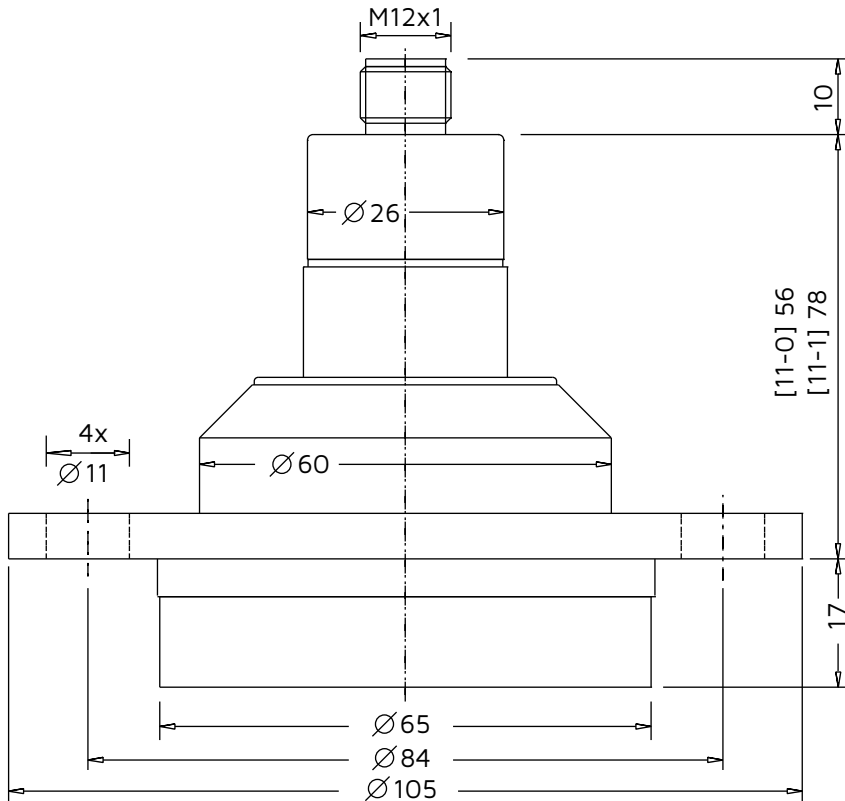

<p>Clamp DIN 32676 - DN20, PN25 [04-U]</p>	<p>Clamp DIN 32676 - DN25-40/1"-1½", ISO 2852 - DN25-38, PN25 [04-S]</p>
<p>Process pressure P_{max} = 40 bar</p>	<p>Process pressure P_{max} = 40 bar</p>

<p>Clamp DIN 32676 - DN50/2", ISO 2852 - DN40-51, PN25 [04-T]</p>
<p>Process pressure P_{max} = 25 bar</p>

3.6. Packaging, transport, storage

The device is protected by packaging. It can handle normal loads during transport. Transport must be carried out in due consideration of the notes on the transport packaging. Nonobservance of these instructions can cause damage to the device.

The delivery must be checked for completeness and possible transit damage immediately at receipt. Ascertained transit damage or concealed defects must be appropriately dealt with.

Up to the time of installation, the packages must be left closed and, unless otherwise indicated, must be stored only under the following conditions:

- Not in the open
- Dry and dust free
- Not exposed to corrosive media
- Protected against solar radiation
- Avoiding mechanical shock and vibration
- Storage and transport temperature -20...+85°C
- Relative humidity 20...85%

3.7. Accessories

For installation and electrical connection an extensive portfolio, that is optimally matched to the device is available:

- Welding sockets
- Reduction adapter
- Gaskets
- Connection cables
- Confectionable connection jacks
- Power amplifiers
- Display and evaluation devices
- Controllers
- Interface converters

4. Installation

4.1. Ambient and process conditions

The correct function of the device within the specific technical data can only be guaranteed, if the permitted ambient and process conditions at the installation place (see chapter Technical Data) will not be exceeded. Hence make sure before mounting that all parts of the instrument exposed to the process (e.g. measuring membrane, process fitting, process seal) are suitable for the existing process conditions (e.g. process pressure, process temperature, chemical properties of the medium, abrasion, mechanical influences).

4.2. Installation place

The installation of the device at locations where high pressure blows can occur should be avoided.

The installation of the device should be made if possible at temperature calmed places. High process temperature steps can produce short-time higher measuring signal deviations.

At high process temperatures a heat transfer to the terminal enclosure can be reduced by isolation of the medium carrying part of the plant or by the use of a temperature decoupler.

At underrun of the dew point, e.g. cold process medium at high environmental temperature, there is the possibility of condensate formation within the pressure measuring sensor, which can lead to temporary increased measurement deviations resp. malfunctions. These deviations are fully reversible by drying the condensate. The use of a device with a strain gauge pressure measuring sensor is recommended.

The installation position can generate a zero value shift (» chapter Technical data) because of the deadweight of the measuring diaphragm.

Pressure measurement in gases:

Install device above the tapping point, so that the condensate can flow into the process.

Use a blocking valve.

Pressure measurement in steams:

Install device after a siphon and a shut-off device below the tapping point. A protective accumulation of water is formed through condensation in the pipe bends. Even in applications with hot steam, a medium temperature < 100 °C on the transmitter is ensured.

Pressure measurement in liquids:

Install device after a shut-off device below or at the same level as the tapping point. Install device below the lowest measuring point. The effective pressure line is always filled with liquid and gas bubbles can bubble up to the process line. Do not mount the device in the fill flow, in the suction area of a pump, in the tank outlet or at a point in the container which could be affected by pressure pulses from an agitator.

4.3. Installation notes

WARNING	Install the device only when the system is pressureless. There is a risk of fast escaping media resp. pressure blow.
----------------	--

WARNING	Let the system cool down sufficiently before installing the device. There is a risk of dangerous and hot media escaping.
----------------	--

Do not remove packaging until just before mounting and check the device for any damage.

The protective cap, which is attached at the process connection resp. the diaphragm, must only be removed immediately before the installation. The diaphragm may not be damaged.

Pollution or damaging of the pressure compensation opening (Hole besides the electrical connection) can lead to faulty measuring results.

Sealing faces and threads at the device and at the installation point must be clean and without damage.

Parallel threads must be sealed by a suitable O-ring, flat or profile gasket. An additional sealing material such as yam, hemp or PTFE tape should not be used.

Tapered threads should be wound with additional sealing material, e.g. PTFE tape for sealing.

NOTE	The installation of the device into a closed off completely with process liquid filled connection can lead to destruction of the measuring diaphragm. The reduction of the volume of the liquid at screw-in leads to a very high pressure boosting, which can exceed the permitted maximum value by a multiple. Thus, before installation, the connection must be sufficiently emptied.
-------------	---

NOTE	The tightening of the thread process connection may only be done at the hexagon by a suitable spanner at most with the maximum permitted torque strength (» chapter Product description - Dimensions).
-------------	--

5. Electrical connection

5.1. Electronic output [09-A] – Current 4...20mA, FSK

5.1.1. Function

The digital communication protocol uses Frequency Shift Keying (FSK) technology and is superimposing onto the analogue sensor signal 4...20mA. This allows a two-way-communication and thus allows the transmission of additional information's, that going above the normal process variables, from or to an intelligent field device.

The communication protocol communicates with 1.200 Bit/s without interrupting the 4...20mA signal and thus allows the host application (master), to receive two or more digital actualizations per seconds from an intelligent field device. The digital signal does not disturb the 4...20mA.

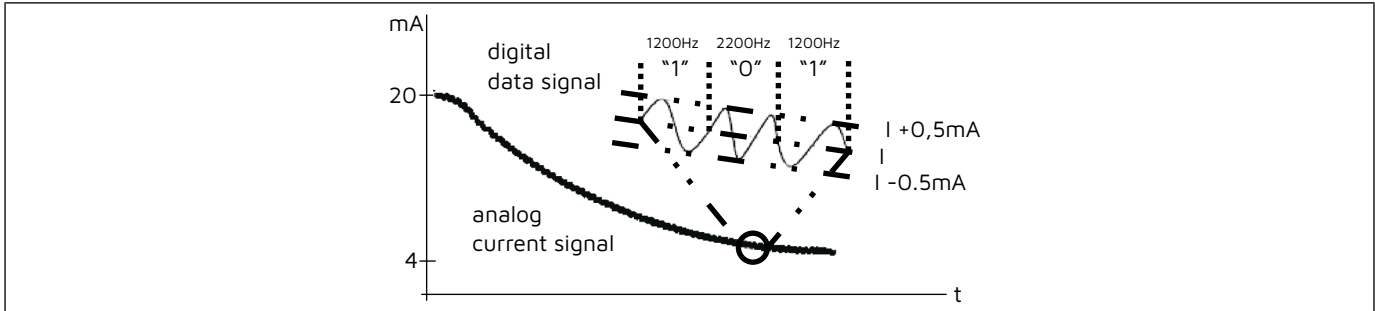

5.1.2. Terminal assignment

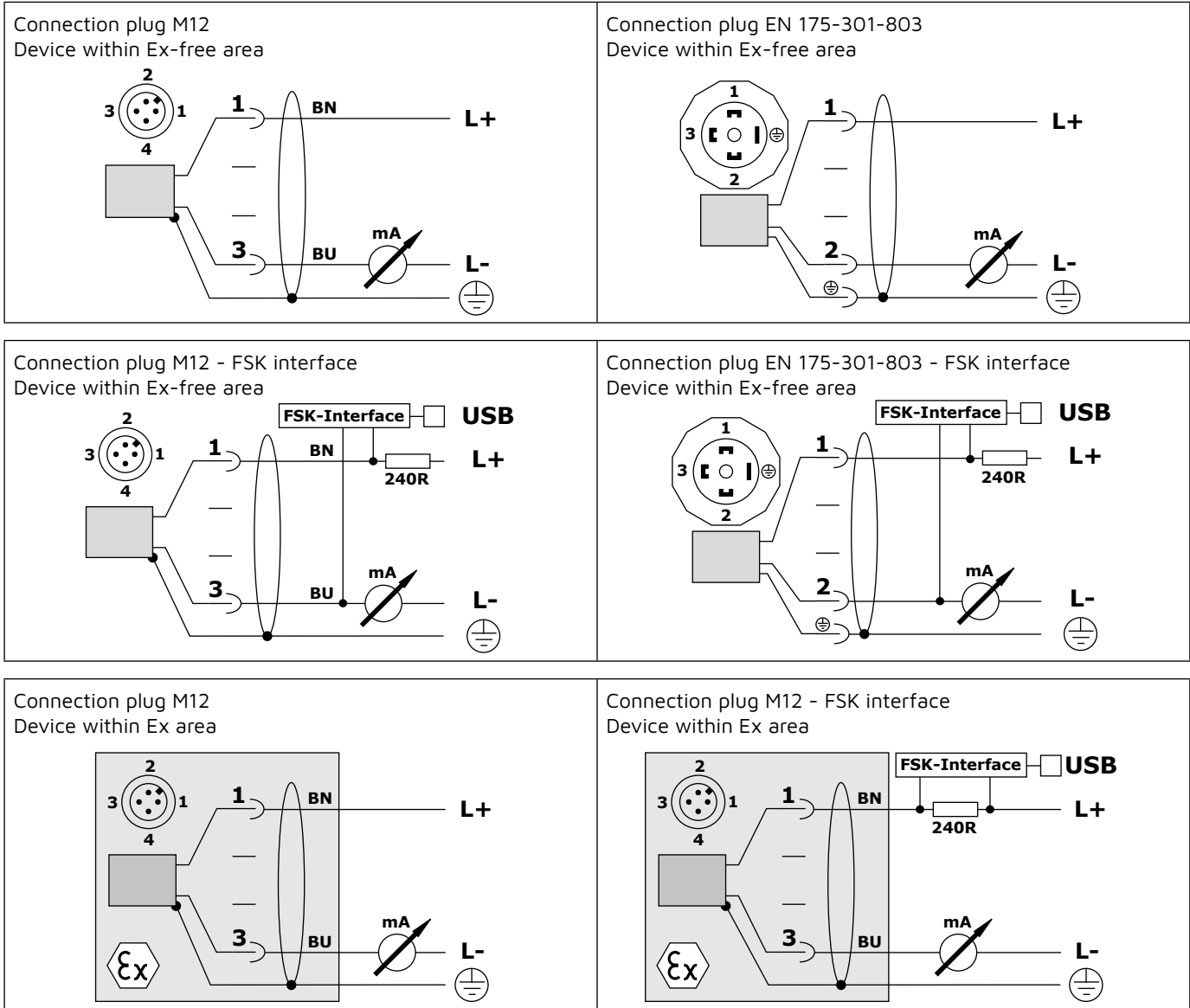

NOTE

Consider resistor 240Ω within wire +L for connection of the FSK-communication device.

5.1.3. Connection cable

Cable: M12 – A-coded, 1-BN = brown / 2-WH = white / 3-BU = blue / 4-BK = black
 Use a cable 2-core, twisted, shielded.

5.1.4. Connection notes

WARNICG	Install the device only in de-energized state.
NOTE	For start-up deactivate all connected control devices, to avoid unwanted control reactions.

Observe maximum permitted supply voltage U_s at the terminals L+/L-:

- $U_s = 9...35VDC$
- Ex: $U_s = 9...30VDC$

Observe maximum permitted load resistor R_L of the analogue output:

- $R_L \leq (U_s - 9V) / 22mA$

The device must be grounded, preferred by the metallic process connection, alternatively by the cable shield.
 Install cable separated from power leading cables, if existing connect shield to earth.

5.1.5. Analogue output I_o

An analogue current signal is generated, that is referred to the nominal measuring range of the device:

- 4 - 20mA output signal range 3,9...20,5mA

Behaviour of the output current values at overriding the output signal range:

- Hold end value 3,9mA / 20,5mA

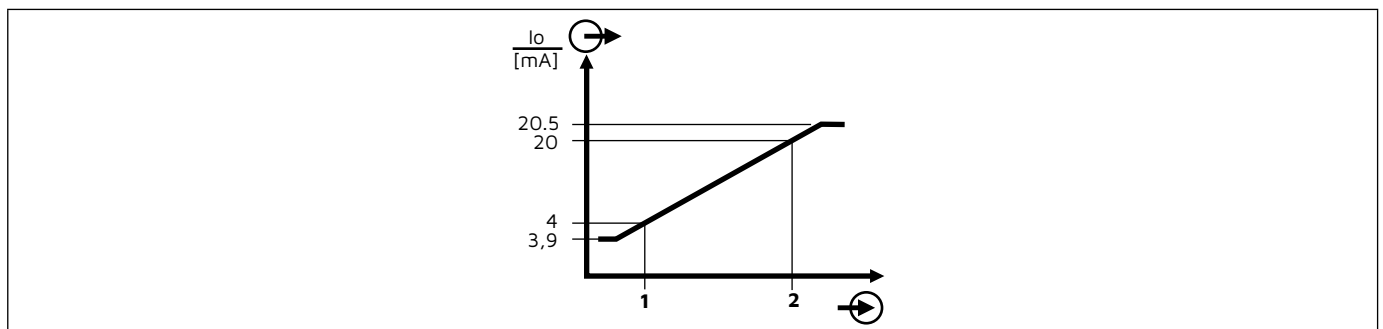

5.2. Electronic output [09-B] – Voltage 0...10V

5.2.1. Function

The measured value is converted into a continuous voltage signal 0...10V.

5.2.2. Terminal assignment

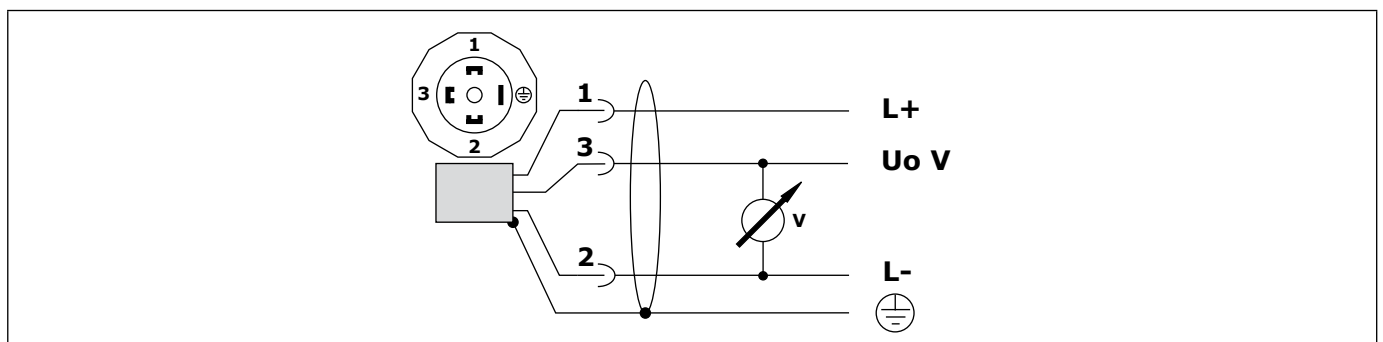

5.2.3. Connection cable

Use a cable 3-core, twisted, shielded.

5.2.4. Connection notes

WARNICG	Install the device only in de-energized state.
NOTE	For start-up deactivate all connected control devices, to avoid unwanted control reactions.

Observe maximum permitted supply voltage U_s at the terminals L+/L-:

- $U_s = 14...35VDC$

Observe minimum permitted load resistor R_L of the analogue output:

- $R_L \geq 5500R$

The device must be grounded, preferred by the metallic process connection, alternatively by the cable shield.

Install cable separated from power leading cables, if existing connect shield to earth.

5.2.5. Analogue output U_o

An analogue voltage signal is generated, that is referred to the nominal measuring range of the device:

- 0 - 10V output signal range 0...10,25V

Behaviour of the output current values at overriding the output signal range:

- Hold end value 0V / 10,25V

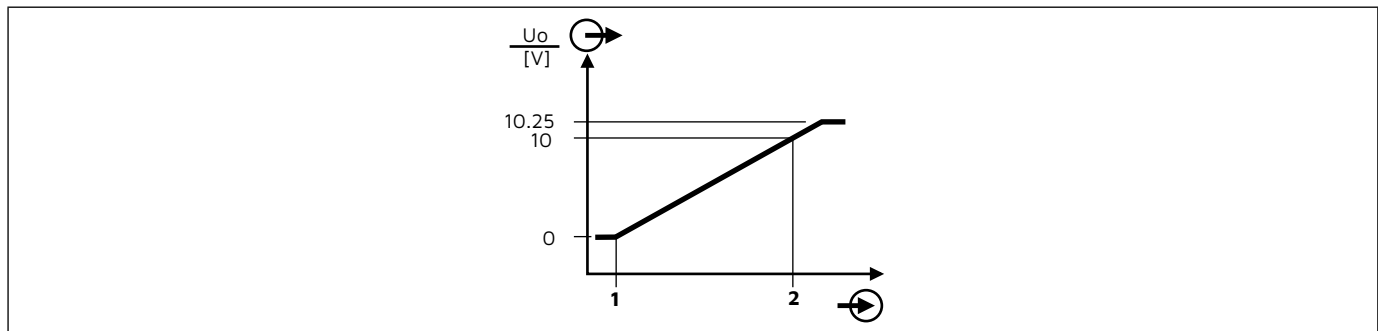

5.3. Electronic output [09-V] – RS485 Modbus-RTU

5.3.1. Function

The Modbus protocol is a communication protocol, that base on a master/slave architecture.

All devices are connected by two data wires (A+ / B-) and by one COMMON-wire (C/L-).

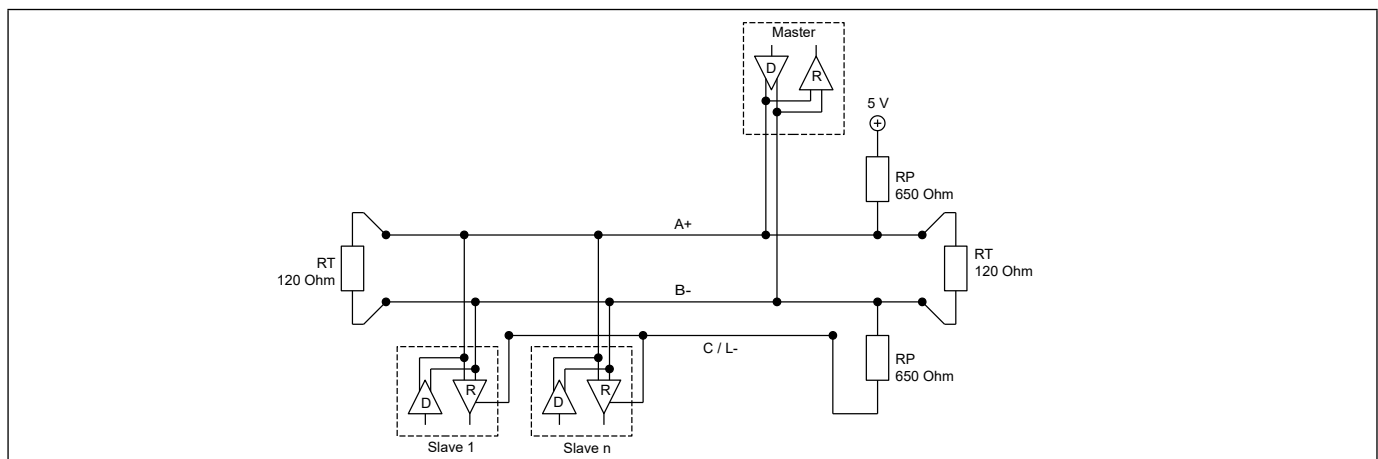

An original RS485 allows the connection of 32 slaves within one segment. The device has a load of only 1/8 of the standard load ($R_{in} \geq 96 k\Omega$), thus up to 256 of the devices can be theoretically operated within one network segment. However the number is limited to 247 due to the Modbus address space.

The both termination resistors R_T prevent reflections on the data wires. The optimum resistor value depends on the wave impedance of the used cable, but a value of 120 Ohm is a popular choice.

The polarisation network is necessary, to ensure suitable potentials, if none of the devices transmits and thus the wires A+ and B- are undefined (high impedance). The value for R_P depends e.g. on bus load or the termination resistors.

Recommended values are between 450 Ohm and 650 Ohm.

Usually the polarisation resistors are implemented within the master device or they are connectible.

Connect the device at bus topology (line). A stub line must be avoided.

5.3.2. Terminal assignment

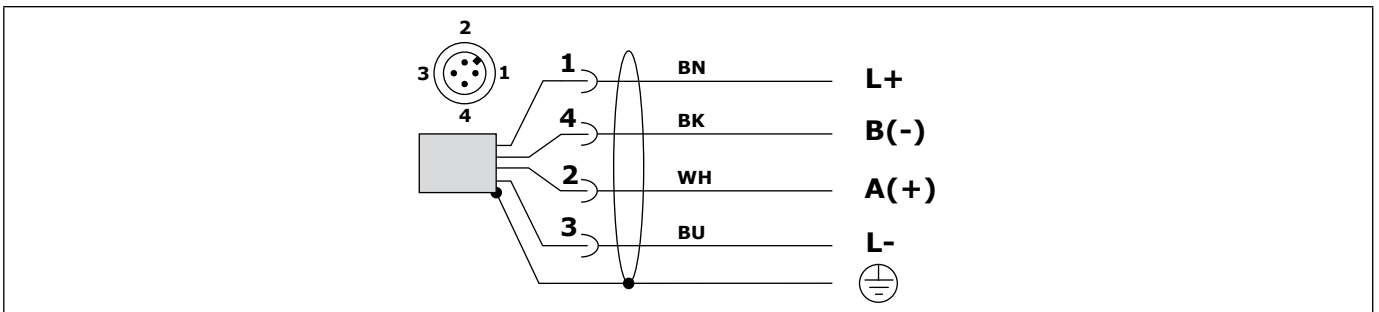

5.3.3. Connection cable

Cable: M12 – A-coded, 1-BN = brown / 2-WH = white / 3-BU = blue / 4-BK = black

Use a cable 4-core acc. to the EIA485 recommendations:

Impedance	135...165Ω @ 3...20Mhz
Cable capacity	< 30pF/m
Cable diameter	> 0,64mm
Cable cross section	0,34 mm ² / AWG 22
Loop resistance	< 110Ω/km
Shielding	Braided shield /shield foil
Cable length	38400 Baud ≤ 1200m

5.3.4. Connection notes

WARNICG	Install the device only in de-energized state.
NOTE	For start-up deactivate all connected control devices, to avoid unwanted control reactions.

Observe maximum permitted supply voltage U_s at the terminals L+/L-:

- $U_s = 6...35VDC$

The device must be grounded, preferred by the metallic process connection, alternatively by the cable shield.

Install cable separated from power leading cables, if existing connect shield to earth.

5.4. Electronic Output [09-L] – IO-Link

5.4.1. Function

IO-Link is a worldwide standardized I/O technology to communicate with sensors. It is a serial bidirectional point-to-point connection.

The IO-Link communication requires an IO-Link-Master.

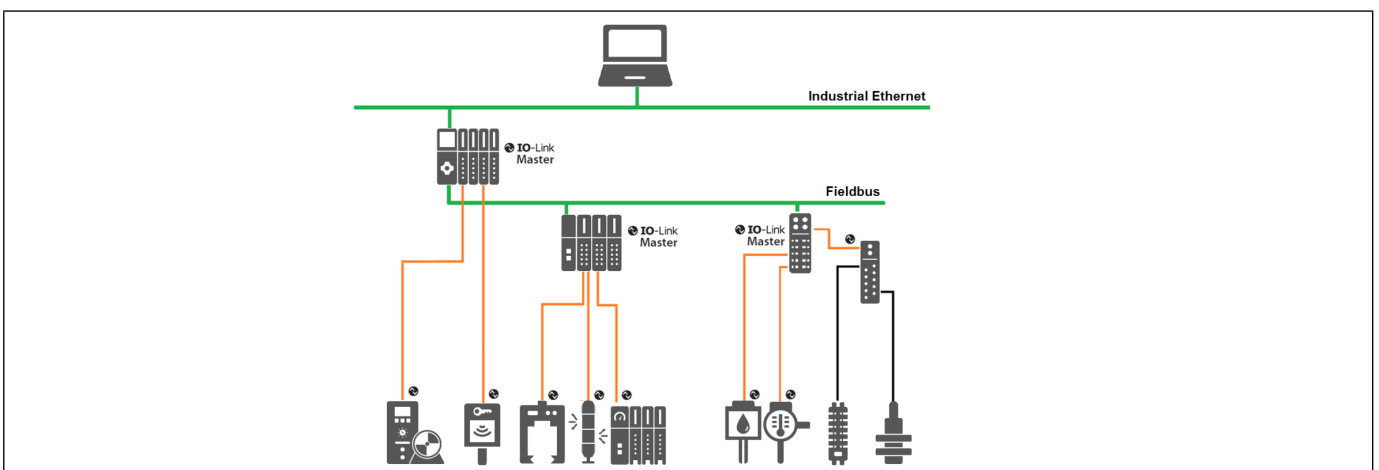

5.4.2. Terminal assignment

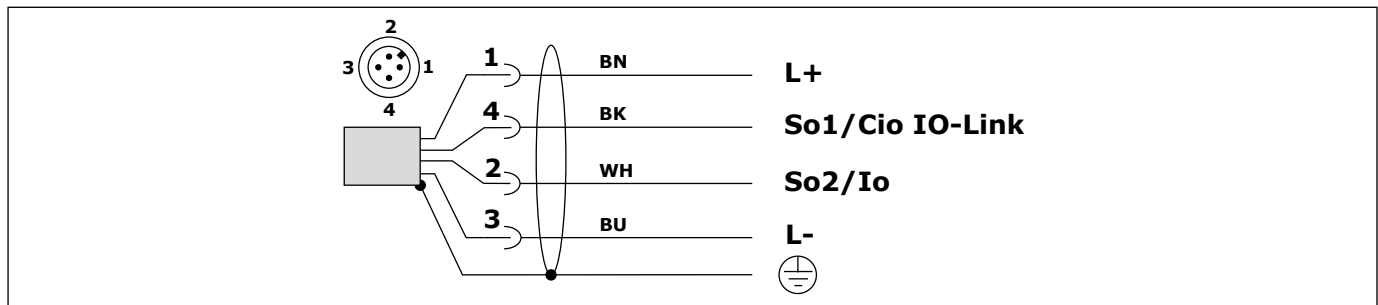

5.4.3. Connection cable

Cable: M12 – A-coded, 1-BN = brown / 2-WH = white / 3-BU = blue / 4-BK = black

Use a cable max. 20m, 3- resp. 4-core, unshielded.

When using the analogue output, a shielded cable must be used.

5.4.4. Connection notes

WARNICG	Install the device only in de-energized state.
NOTE	For start-up deactivate all connected control devices, to avoid unwanted control reactions.
NOTE	Inductive loads at the switch outputs, e.g. contactors or magnetic vents may only be used with a free-wheeling diode or a RC protection circuit.
NOTE	Standard configuration of the outputs: <ul style="list-style-type: none"> • So1 >> Switch PP + Cio IO-Link • So2 >> Analogue Io 4...20mA

Observe maximum permitted supply voltage U_s at the terminals L+/L-:

- $U_s = 9...35VDC$
- $U_s = 18...30VDC$, IO-Link

Observe maximum permitted load resistor R_L of the analogue output:

- $R_L \leq (U_s - 8V) / 22mA$

The device must be grounded, preferred by the metallic process connection, alternatively by the cable shield.

Install cable separated from power leading cables, connect shield to earth.

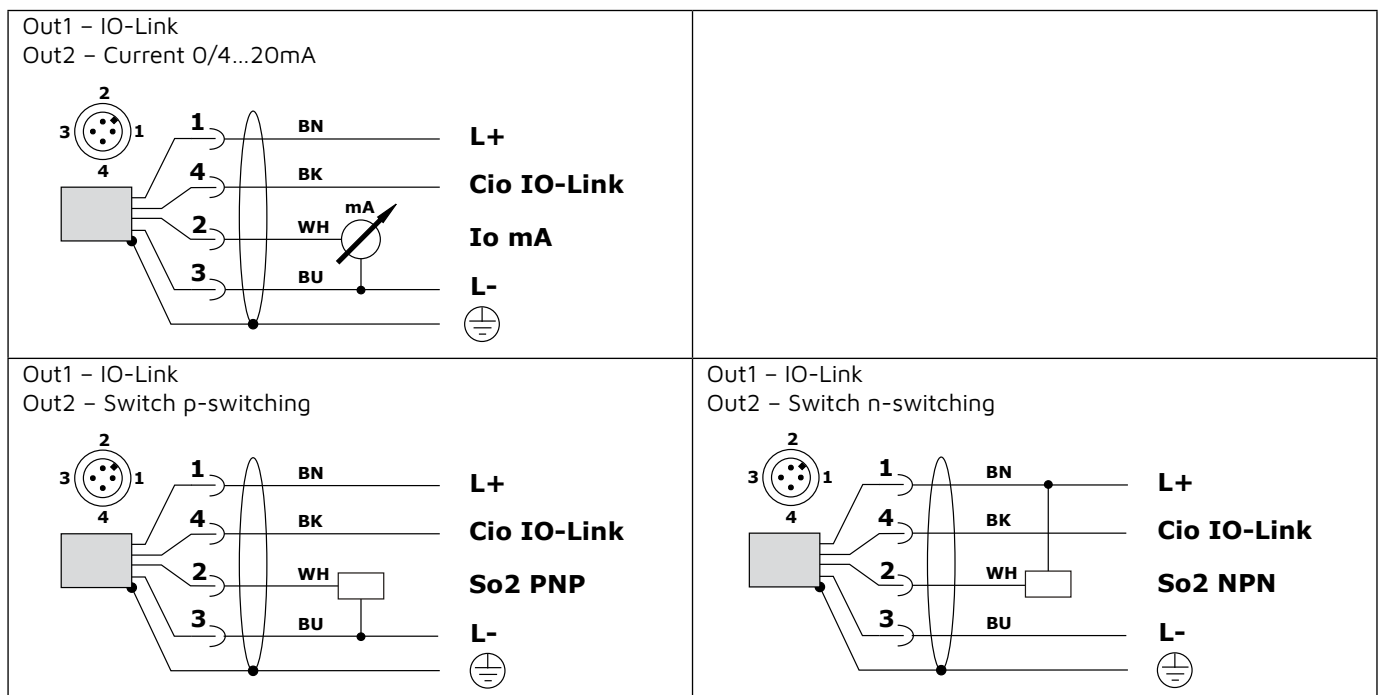

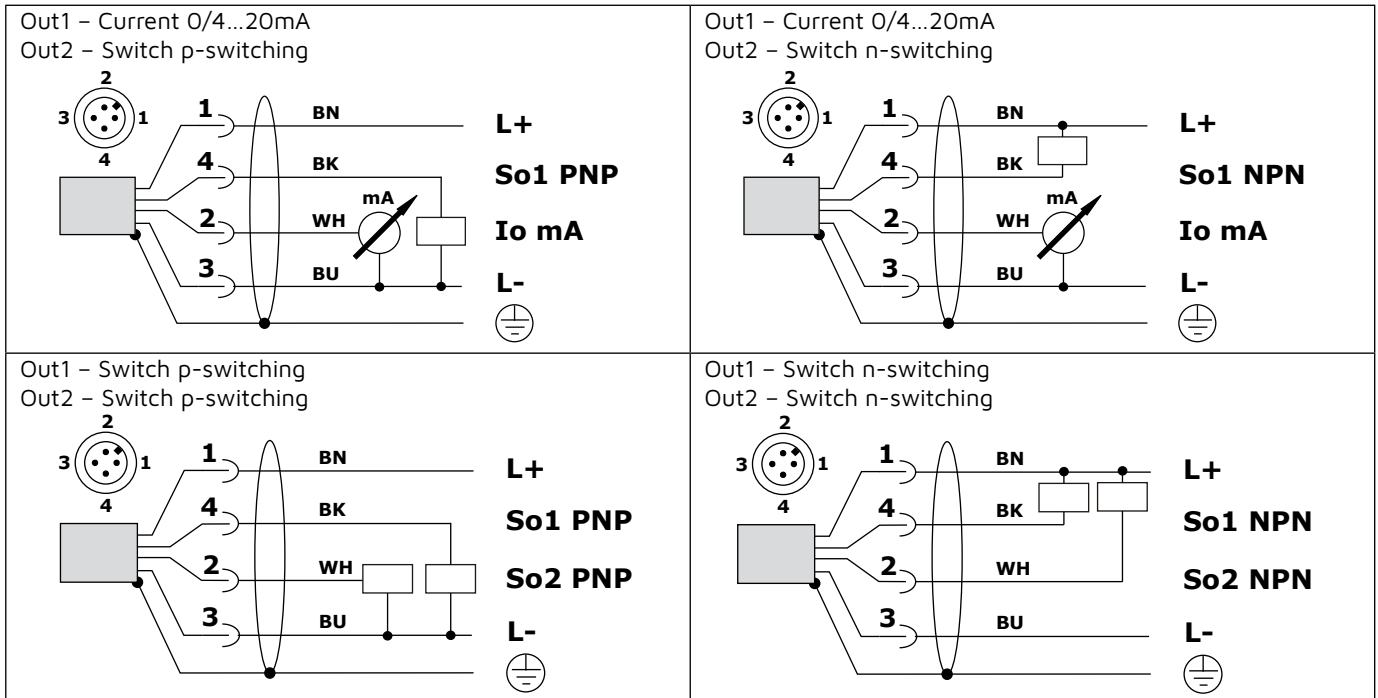

6. Operation

Parameterization and operation can be made by the electronic variant dependent integrated wired interface. Knowledge concerning the communication technology is provided.

6.1. Electronic output [09-A] – Current 4...20mA, FSK

Configuration and data transmission can be made per standard FSK interface, e.g. isHRT USB resp. isHRT USBx and operating software.

The use of the DTM isHRT CommDTM resp. ICS Generic HART DTM is recommended.

Information's for installation resp. using the FSK interface resp. the operating software are not content of this manual.

NOTE	<p>At a set damping from 0s...<1s the communication is only active for 20s after power-up the supply voltage. After establishing the connection it will be stay active. While this, the damping is set to 1s. After 4 minutes of inactivity the connection will be terminated and the damping is reset to the set value. At a set damping of $\geq 1s$ the establishing of a communication connection is always possible.</p>
-------------	---

Default settings [Adjustment range]:

	Default settings	Description
Address	0 [0...15]	
Damping	0s [0s...60s]	Unit s / Damping measuring value pressure exponential = 99,9% measuring value
Start value LRV	Nominal lower adjust value = 4mA	LRV < URV Span $\geq 25\%$
End value URV	Nominal upper adjust value = 20mA	LRV < URV Span $\geq 25\%$

6.2. Electronic output [09-B] – Voltage 0...10V

Parameterization and operation are not possible.

6.3. Electronic output [09-V] – RS485 Modbus-RTU

Operation is via the wired interface.

Information on installing and using the interface and operating software is not included in this manual.

6.3.1. Parameter

The parameter file and description can be downloaded from the website www.acs-controlsystem.com. Setting ranges and default values for all parameters are provided.

6.4. Electronic output [09-L] – IO-Link

Operation is via the wired interface.

Information on installing and using the interface and operating software is not included in this manual.

6.4.1. Parameter

The parameter file and description can be downloaded from the website www.acs-controlsystem.com. Setting ranges and default values for all parameters are provided.

6.4.2. Switch output So

Operation Mode

Depending on the operation mode [O1_Conf/O2_Conf+Operation Mode], the output will be switched differently:

- PP (Push-Pull) Auxiliary supply voltage +L <--> Auxiliary supply voltage -L
- NPN Auxiliary supply voltage -L <--> off - high-impedance
- PNP Auxiliary supply voltage +L <--> high-impedance
- Analog Out Current output Io 0/4...20mA

For the switch output So1 only the operation mode PP can be selected.

Switch Mode

For the switch outputs different switch modes [O1_Conf/O2_Conf+Switch Mode] can be selected:

Deactivated

The switch output is deactivated and thus high-impedance.

Single Point Mode

The switch output is activated, if the measuring value overrides the switch point [O1_SP/O2_SP] and the switch on delay time [O1_dS/O2_dS] is expired.

The switch output is deactivated, if the measuring value fall below the switch point [O1_SP/O2_SP] and the switch off delay time [O1_dR/O2_dR] is expired.

At polarität [O1_Conf/O2_Conf+Polarity+NO] the reset point is lower by the hysteresis [O1_HY/O2_HY] than the set switch point [O1_SP/O2_SP].

At polarität [O1_Conf/O2_Conf+Polarity+NC] the effective switch point is higher by the hysteresis [O1_HY/O2_HY] than the switch point [O1_SP/O2_SP].

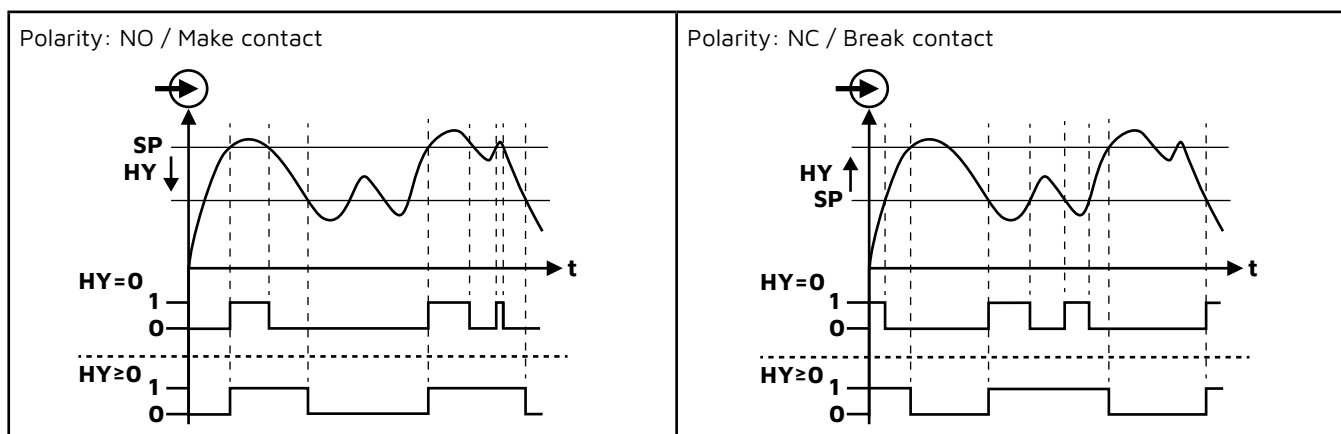

Window Mode

The switch range is determined by specification of switch point [O1_SP/O2_SP] and reset point [O1_RP/O2_RP].

The switch output is activated, if the measuring value is within the range, defined by switch point [O1_SP/O2_SP] and reset point [O1_RP/O2_RP] and the switch on delay time [O1_dS/O2_dS] is expired.

The switch output is deactivated, if the measuring value is outside the range, defined by switch point [O1_SP/O2_SP] and reset point [O1_RP/O2_RP] and the switch off delay time [O1_dR/O2_dR] is expired.

The hysteresis [O1_HY/O2_HY] generates a switch offset symmetrically at switch point [O1_SP/O2_SP] and at reset point [O1_RP/O2_RP].

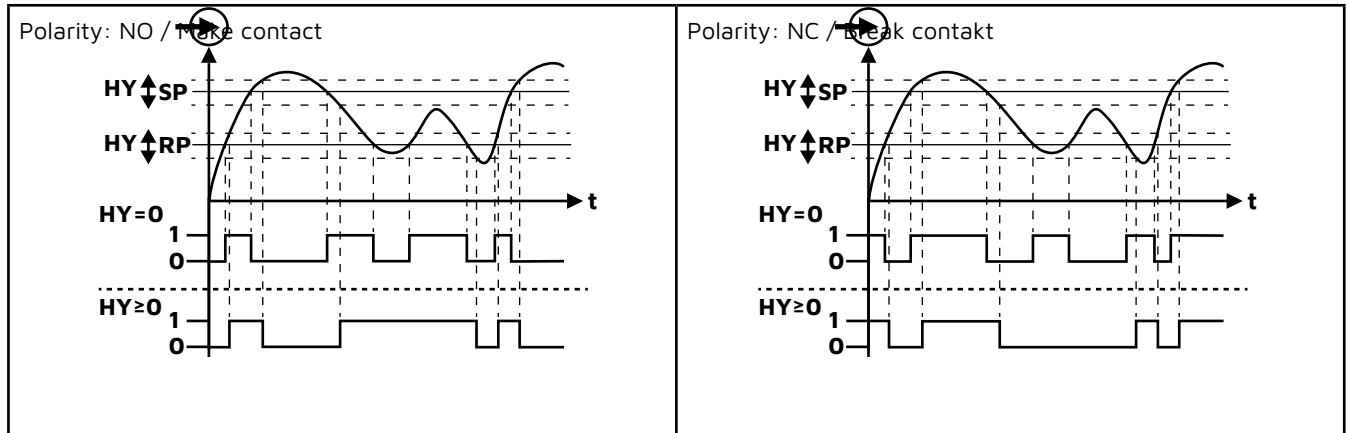

Two Point Mode Mode

The switch range is determined by specification of switch point [O1_SP/O2_SP] and reset point [O1_RP/O2_RP].

The switch output is activated, if the measuring value overrides the switch point [O1_SP/O2_SP] and the switch on delay time [O1_dS/O2_dS] is expired.

The switch output is deactivated, if the measuring value fall below the switch point [O1_SP/O2_SP] and the switch off delay time [O1_dR/O2_dR] is expired.

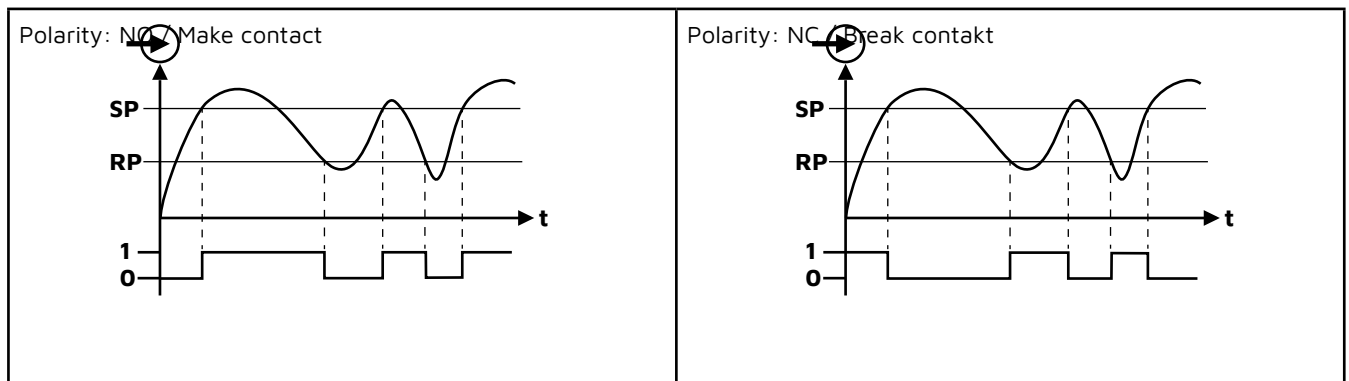

Error indication function

The switch output indicates a detected functional error (» chapter Errordiagnosis and Troubleshooting)

6.4.3. Analogue output I_o

An analogue current signal is generated, that is referred to the nominal measuring range of the device:

- 0 – 20 mA output signal range 0...20,5mA
- 4 – 20mA output signal range 3,8...20,5mA
- 20 – 0 mA output signal range 20,5...0mA
- 20 – 4 mA output signal range 20,5... 3,8mA

A free assignment to measuring input values in the range of the nominal measuring range is possible.

Behaviour of the output current values at overriding the output signal range acc. to Namur NE43:

- (1) Hold end value 0/3,8mA/20,5mA
- (2) Step $\leq 3,6$ mA
- (3) Step ≥ 21 mA (22mA)

Output signal 4-20mA

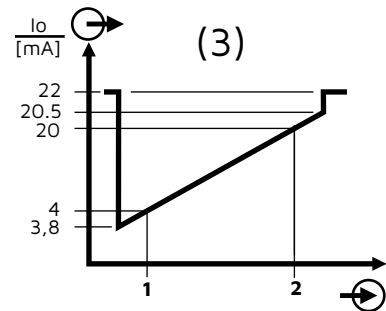
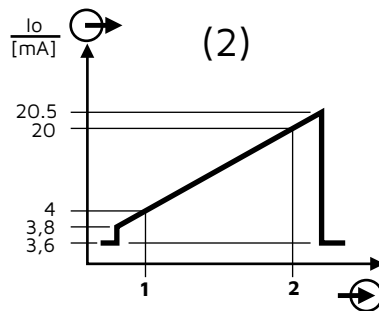
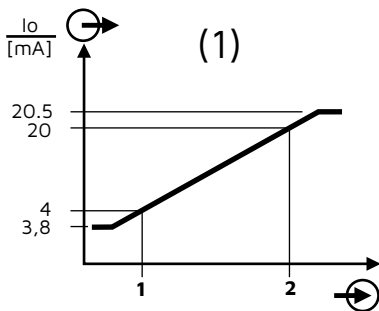

Output signal 0-20mA

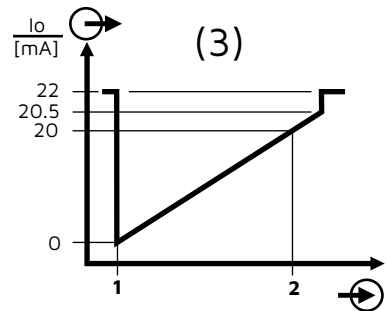
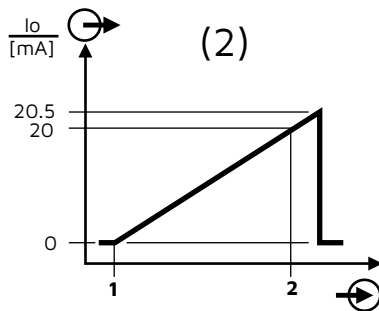
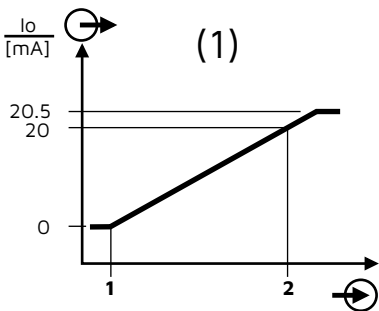

7. Error diagnosis and Troubleshooting

The operator of the system is responsible for taking suitable measures to rectify faults.

Error indication Electronic output [09-L] – IO-Link:

IO-Link Code	Description	Troubleshooting
20480 (0x5000)	Error device hardware	Replace device or send in for repair
35856 (0x8C10)	Override measuring range	Check adjustment measuring range
35888 (0x8C30)	Underrun measuring range	Check adjustment measuring range
36346 (0x8DFA)	Analogue output error 3,6mA	Check adjustment current output
36347 (0x8DFB)	Analogue output error 22mA	Check adjustment current output

In case of malfunction check:

Component / area	Check	Troubleshooting
Enclosure	Damage	Replace device or send in for repair
Pressure membrane	Pollution	Clean device or send in for repair
	Damage	Replace device or send in for repair
Process gasket	Damage	Replace process seal
		Use other seal material if necessary
Druckausgleichskapillare	Verschmutzung	Gerät zur Reparatur einsenden
Supply voltage	Operating voltage available	Switch-on resp. repair operating voltage
		Check terminals resp. repair
	Operating voltage reverse connected	Reverse operation voltage connection
	Operating voltage too low	Adapt resp. repair
	Operating voltage too high	Send in device for repair
	Load resistance too high	Reduce resistance
	Increase operating voltage	
Connection cable damaged		Change resp. repair cable

If the malfunction cannot be eliminated, please contact the manufacturer.

8. Maintenance

At appropriate use, the device is free of maintenance.

Solid coatings on the diaphragm can lead to faulty measurement results. In this case the diaphragm must be regularly cleaned. Don't use sharp resp. hard tools, pressured air or aggressive chemicals. For dismantling the device see chapter "Dismounting".

9. Repair

The device is not intended for repair by the user. A repair may only be carried out by the manufacturer.

9.1. Dismounting

Use suitable protective clothing, e.g. goggles, gloves.

WARNING	Let the device and the system cool down sufficiently fore dismounting it. There is a risk of hot surfaces as well as dangerous and hot media escaping.
WARNING	Dismount the device only when the system is pressureless. There is a risk of fast escaping media resp. pressure blow.
NOTE	Dismount the device only in de-energized state. Deactivate all connected control devices

After dismounting the diaphragm and the connection plug must be provided with a protection cap.

9.2. Return

Returns can only be accepted if the device has been equipped with a Decontamination declaration enclosed. The decontamination declaration is available at <https://www.acs-controlsystem.com> at the download area and must be completely filled in, and affixed securely and weather-proof to the outside of the packaging.

9.3. Disposal



As required by the Directive 2012/19/EU on waste electrical and electronic equipment (WEEE), products of ACS are marked with the depicted symbol in order to minimize the disposal of WEEE as unsorted municipal waste. Such products may not be disposed of as unsorted municipal waste and can be returned to ACS for disposal.

The return follows the conditions stipulated in the General Terms and Conditions or as individually agreed by ACS.

10. Technical Data

Reference conditions	T _a = +15°C..+25°C (+59°F..+77°F) / p _a = 860..1060kPa / r.F. = 45..75% t _{on} = 240s / U _s = 24VDC±0,1V / vertical, sensor downside
Measurement deviation	EN/IEC 60770-1: Characteristic deviation - Limit value adjustment

10.1. Input

10.1.1. Input pressure

Sensor type	Capacitive cell
Resolution	FSI ≥ 16 Bit
Characteristic deviation	≤ ±0,05%FSI / ±0,1%FSI / ±0,2%FSI
Hysteresis	negligible
Reproducibility	negligible
Influence supply voltage	≤ ±0,002%FSI/V
Influence temperature	Tk zero ≤ ±0,015%FSI/K, ≤ ±0,75%FSI (-20°C...+80°C) Tk span ≤ ±0,015%FSI/K Tk span ≤ ±0,5%FSI (-20°C...+80°C/≥0,4bar) / ±0,8%FSI (-20°C...+80°C/<0,4bar)
Influence mounting pos.	≤ 0,18mbar (Position: vertical, sensor topside)
Long term drift zero	≤ ±0,15%FSI/year

10.1.2. Input pressure - Gauge pressure [12-R]

Process connection	ISO 228-1 - [04-1/2/3/4/5/6/8/9]	AISI NPT - [04-E/C]
Membrane D18mm	DIN 11851 - [04-R]	Clamp DIN 32676-A - [04-U]

Type code Meas. range	[08-15]	[08-18]	[08-16]	[08-17]	[08-26]	[08-01]
Meas. range PN – FSI	-0,1..0 bar	-0,1..0,1 bar	-1..0 bar	-1..1 bar	0..0,05 bar	0..0,1 bar
Overload pressure	4 bar	5 bar	10 bar	18 bar	4 bar	4 bar
Vacuum pressure, abs.	0,7 bar	0 bar	0 bar	0 bar	0,7 bar	0,7 bar

Type code Meas. range	[08-02]	[08-03]	[08-04]	[08-05]	[08-06]	[08-07]
Meas. range PN – FSI	0..0,2 bar	0..0,4 bar	0..0,6 bar	0..1 bar	0..1,6 bar	0..2,5 bar
Overload pressure	5 bar	6 bar	10 bar	10 bar	18 bar	25 bar
Vacuum pressure, abs.	0 bar	0 bar	0 bar	0 bar	0 bar	0 bar

Type code Meas. range	[08-08]	[08-09]	[08-10]	[08-11]	[08-12]	[08-13]
Meas. range PN – FSI	0..4 bar	0..6 bar	0..10 bar	0...16 bar	0..20 bar	0..40 bar
Overload pressure	25 bar	40 bar	40 bar	40 bar	40 bar	60 bar
Vacuum pressure, abs.	0 bar	0 bar	0 bar	0 bar	0 bar	0 bar

Type code Meas. range	[08-14]	[08-19]				
Meas. range PN – FSI	0..60 bar	0..100 bar				
Overload pressure	150 bar	150 bar				
Vacuum pressure, abs.	0 bar	0 bar				

Process connection	ISO 228-1 - [04-7]	DIN 11851 - [04-N/M]
Membrane D32mm	Varivent - [04-P]	DRD - [04-L]
	Clamp DIN 32676-A/-C / ISO 2852 - [04-S/T]	

Type code Meas. range	[08-15]	[08-18]	[08-16]	[08-17]	[08-26]	[08-01]
Meas. range PN – FSI	-0,1..0 bar	-0,1..0,1 bar	-1..0 bar	-1..1 bar	0..0,05 bar	0..0,1bar
Overload pressure	4 bar	5 bar	10 bar	18 bar	4 bar	4 bar
Vacuum pressure, abs.	0,7 bar	0,5 bar	0 bar	0 bar	0,7 bar	0,7 bar

Type code Meas. range	[08-02]	[08-03]	[08-04]	[08-05]	[08-06]	[08-07]
Meas. range PN – FSI	0..0,2bar	0..0,4bar	0..0,6bar	0..1 bar	0..1,6 bar	0..2,5 bar
Overload pressure	5 bar	8 bar	10 bar	10 bar	18 bar	25 bar
Vacuum pressure, abs.	0,5 bar	0 bar	0 bar	0 bar	0 bar	0 bar

Type code Meas. range	[08-08]	[08-09]	[08-10]	[08-11]	[08-12]	[08-13]
Meas. range PN – FSI	0..4 bar	0..6 bar	0..10 bar	0...16 bar	0..20 bar	0..40 bar
Overload pressure	25 bar	40 bar	40 bar	60 bar	60 bar	60 bar
Vacuum pressure, abs.	0 bar	0 bar	0 bar	0 bar	0 bar	0 bar

10.1.3. Input pressure - Absolute pressure [12-A]

Process connection	ISO 228-1 - [04-1/2/3/4/6/8/9]			AISI NPT - [04-E/C]		
Membrane D18mm	DIN 11851 - [04-R]			Clamp DIN 32676-A - [04-U]		
Type code Meas. range	[08-01]	[08-02]	[08-03]	[08-04]	[08-05]	[08-06]
Meas. range PN – FSI	0..0,1 bar	0..0,2 bar	0..0,4 bar	0..0,6 bar	0..1 bar	0..1,6 bar
Overload pressure	4 bar	5 bar	6 bar	10 bar	10 bar	18 bar
Type code Meas. range	[08-07]	[08-08]	[08-09]	[08-10]	[08-11]	[08-12]
Meas. range PN – FSI	0..2,5 bar	0..4 bar	0..6 bar	0..10 bar	0..16 bar	0..20 bar
Overload pressure	25 bar	25 bar	40 bar	40 bar	40 bar	40 bar
Type code Meas. range	[08-13]	[08-14]	[08-19]			
Meas. range PN – FSI	0..40 bar	0..60 bar	0..100 bar			
Overload pressure	60 bar	150 bar	150 bar			

Process connection	ISO 228-1 - [04-7]			DIN 11851 - [04-N/M]		
Membrane D32mm	Varivent - [04-P]			DRD - [04-L]		
	Clamp DIN 32676-A/-C / ISO 2852 - [04-S/T]					
Type code Meas. range	[08-01]	[08-02]	[08-03]	[08-04]	[08-05]	[08-06]
Meas. range PN – FSI	0..0,1bar	0..0,2bar	0..0,4bar	0..0,6bar	0..1 bar	0..1,6 bar
Overload pressure	4 bar	5 bar	8 bar	10 bar	10 bar	18 bar
Type code Meas. range	[08-07]	[08-08]	[08-09]	[08-10]	[08-11]	[08-12]
Meas. range PN – FSI	0..2,5 bar	0..4 bar	0..6 bar	0..10 bar	0..16 bar	0..20 bar
Overload pressure	25 bar	25 bar	40 bar	40 bar	60 bar	60 bar
Type code Meas. range	[08-13]					
Meas. range PN – FSI	0..40 bar					
Overload pressure	60 bar					

10.2. Electronic output [09-A] – Current 4...20mA, FSK

Interface- Cio	
Spezification	FSK / 1200 Bit/s
Coupling resistor	≥ 240Ω, external
Analogue output - Io	
Signal range	3,9...20,5mA, Measuring range [08] = 4...20mA, error ≤ 3,9mA / ≥ 20,5mA
Resolution	≤ 1μA
Permitted load RL	≤ (Us - 9V) / 20,5mA
Time behaviour t90-min	≤ 8ms (td = 0s)
Influence supply voltage	≤ ±0,5μA/V
Influence temperature Ta	≤ ±1μA/K
Auxiliary power	
Supply voltage Us	9...35VDC reverse polarity protected / Ripple voltage ≤ 2Vpp
Input current Is	≤ 20,5mA
Ready delay time	≤ 0,1s (td = 0s)

10.3. Electronic output [09-B] – Voltage 0...10V

Analogue output – U_o	
Signal range	0...10,25V, Measuring range [08] = 0...10V, error 0V / $\geq 10,25V$
Resolution	$\leq 1mV$
Permitted load RL	$\geq U_o / 2mA$
Time behaviour t ₉₀ -min	$\leq 8ms$ (td = 0s)
Influence supply voltage	$\leq \pm 0,5mV/V$
Influence temperature Ta	$\leq \pm 1mV/K$
Auxiliary power	
Versorgungsspannung U _s	14...35VDC reverse polarity protected / Ripple voltage $\leq 2V_{pp}$
Eingangsstrom I _s	$\leq 25mA$ (I _{uo} = 0mA)
Einschaltverzögerungszeit	$\leq 0,1s$ (td = 0s)

10.4. Electronic output [09-V] – RS485 Modbus-RTU

Interface - Cio	
Specification	RS485, bidirektional / Modbus-RTU / 4,8...38,4 kBaud
Input resistor	112k Ω
Time behaviour t ₉₀ -min	$\leq 2ms$ (td = 0s)
Auxiliary power	
Supply voltage U _s	6...35VDC reverse polarity protected / Ripple voltage $\leq 2V_{pp}$
Input current I _s	$\leq 10mA$ (Co = 0mA)
Ready delay time	$\leq 0,1s$ (td = 0s)

10.5. Electronic output [09-L] – IO-Link

Interface - Cio	
Specification	IO-Link V1.1 / Port Class A / Com2 (38,4 kBaud), Com3 (230,4 kBaud)
Cycle time	$\geq 2,3ms$
Time behaviour t ₉₀ -min	$\leq 2ms$ (td = 0s)
Switch output - So	
Specification	2x PP (Push-Pull), switch to +L/-L
Output signal U _o	$\leq 0,2V... \geq (U_s - 2V) / I_o = 0...200mA$ (current limited $\leq 450mA$, short circuit protected)
Time behaviour t ₉₀ -min	$\leq 2ms$ (td = 0s) / trise < 30 μs (RL < 3k Ω / IO _{out} > 4,5mA)
Switch cycles	$\geq 100.000.000$
Analogue output – I_o	
Signal range	3,8...20,5mA, measuring range [08] = 4...20mA, error $\leq 3,6mA / \geq 21mA$ 0...20,5mA, measuring range [08] = 0...20mA, error $\leq 0,05mA / \geq 21mA$
Resolution	$\leq 1\mu A$
Permitted load RL	$\leq (U_s - 8V) / 22mA$
Time behaviour t ₉₀ -min	$\leq 2ms$ (td = 0s)
Influence supply voltage	$\leq \pm 0,5\mu A/V$
Influence temperature	$\leq \pm 0,5\mu A/K$
Auxiliary power	
Supply voltage U _s	IO-Link inactive: 9...35VDC reverse polarity protected / Ripple voltage $\leq 2V_{pp}$ IO-Link active: 18...30VDC reverse polarity protected / Ripple voltage $\leq 2V_{pp}$
Input current I _s	$\leq 20mA$ (Co / So / I _o = 0mA)
Ready delay time	$\leq 0,1s$ (td = 0s)

10.6. Environmental conditions

Process temperature T _p	[11-0]: -40...+100°C (-40°F...+212°F)
	[11-1]: -40...+125°C (-40°F...+257°F) / +140°C (+284°F) – 1h
	[05-1] (FKM/FPM): -25...+140°C (-13°F...+284°F)
	[05-3] (EPDM): -40...+140°C (-40°F...+284°F)
	[05-4/6] (FFKM): -15...+140°C (-5°F...+284°F)
	[03-X] (ATEX/IECEX): acc. to certificate ATEX/IECEX
Pressure cycles	≥ 100 Mio. (1,2xPN)
Ambient temperature T _a	[03-S]: -40...+100°C (-40°F...+212°F)
	[03-X] (ATEX/IECEX): acc. to certificate ATEX/IECEX
Protection level	IP69K/IP67 (EN/IEC 60529)
Climatic classification	4K4H (EN/IEC 60721-3-4)
Shock classification	50g [1ms] (EN/IEC 60068-2-27)
Vibration classification	20g [10...2000 Hz] (EN/IEC 60068-2-6)
EM compatibility	Operation device class B / Industrial range (EN/IEC 61326)
Insulation voltage	500Vac
Protection class	III
Pollution degree	4
Altitude above sea level	2000m above sea level
MTTF	[09-A]: 745 years / [09-B]: 610 years / [09-V]: 561 years / [09-L]: 601 years
Weight	0,2...0,5kg

10.7. Materials

Process wetted	Ceramic Al ₂ O ₃ – 99,9%
	Steel 1.4404/316L, steel 1.4571/316Ti
	FKM/FPM, EPDM, FFKM
Not process wetted	CrNi-steel, PUR, PA, Acrylic copolymer, FKM/FPM, NBR

11. Revision

Version	Changes
BA10.16	Original version
BA09.18	Add ATEX/IECEX
	Add IO-Link
BA06.25	Add plug EN 175-301-803-A/-C
	Add output 0...10V
	Add measuring range 0...40/60/100bar
	Add process connection [08-2/-7/-E/-C/-U]
	Membrane ceramic Al ₂ O ₃ – 99,9%



FEEL FREE TO
CONTACT US

ACS-CONTROL-SYSTEM GmbH
Lauterbachstr. 57
84307 Eggenfelden - Germany
info@acs-controlsystem.de
www.acs-controlsystem.com
+49 (0) 8721-9668-0