

OPERATING MANUAL - BA06.23

Radarcont RU4SR

Electronic Radar filling level sensor
with freely radiating 122GHz FMCW signal



Index	
1.	About this document 3
1.1.	Dokument function 3
1.2.	Terms 3
1.3.	Other documents 3
2.	Safety instructions 4
2.1.	Autorized personnel 4
2.2.	Appropriate use 4
2.3.	Operational safety 4
3.	Product description 5
3.1.	Function 5
3.2.	Construction 5
3.3.	Product label 5
3.4.	Product code 6
3.5.	Dimensions 6
3.6.	Packaging, transport, storage 7
3.7.	Accessories 7
4.	Installation 8
4.1.	Ambient and process conditions 8
4.2.	Installation place 8
4.3.	Standpipe 9
4.4.	Installation notes 9
5.	Electrical connection 10
5.1.	Electronic output [05-V] – RS485 Modbus-RTU 10
5.1.1.	Function 10
5.1.2.	Terminal assignment 10
5.1.3.	Connection cable 10
5.1.4.	Connection notes 11
5.2.	Electronic Output [05-L] – IO-Link 11
5.2.1.	Function 11
5.2.2.	Terminal assignment 11
5.2.3.	Connection cable 11
5.2.4.	Connection notes 12
6.	Operation 13
6.1.	Electronic output [05-V] – RS485 Modbus-RTU 14
6.2.	Electronic output [05-L] – IO-Link 16
6.2.1.	Parameter 16
6.2.2.	Switch output So 17
6.2.3.	Analogue output Io 18
7.	Error diagnosis and Troubleshooting 19
8.	Maintenance 19
9.	Repair 19
9.1.	Dismounting 19
9.2.	Return 19
9.3.	Disposal 19
10.	Technical Data 20
10.1.	Input distance 20
10.2.	Electronic output [05-V] – RS485 Modbus-RTU 20
10.3.	Electronic output [05-L] – IO-Link 20
10.4.	Process conditions 21
10.5.	Environmental conditions 21
10.6.	Materials 21
11.	Revision 21

1. About this document

1.1. Dokument function

These instructions for use describe the structure, functions and the use of the product and will help to operate the product as intended.

Read these instructions carefully before using the product. This is to avoid possible damage to persons, property or the device.

The Operating manual is part of the device and must be kept always accessible nearest its installation location.

All statements within this document correspond to the information available at the time of printing. Subject to change without prior notice.

1.2. Terms

NOTE	Notes to prevent failures, malfunctions, damage to devices or plants.
WARNING	Non-observance of the information may result in serious or fatal personal injury.
[04-5]	Exemplary notice to a type variant (>> chapter Product description - Product code)

1.3. Other documents

Besides this document the following material can be found on the Internet at www.acs-controlsystem.com:

- IO-Link parameter list
- EU Declaration of Conformity (current version)
- Manufacturer declarations
- Certificates
- 3D-CAD models

2. Safety instructions

2.1. Authorized personnel

Installation, electrical connection, commissioning, operation, maintenance, dismantling and disposal of the device must be made by a qualified and authorized expert according to the information's in the Operating manual and the relevant standards and rules.

This expert must have read and understood the Operating manual and especially the safety instructions. During work on and with the device, the required personal protective equipment must always be worn.

2.2. Appropriate use

The device is an electronic radar filling level sensor for continuous measurement of filling levels in liquid media.

The operational reliability of the device is ensured only at the intended use. Inappropriate or incorrect use of this product can give risk to application specific hazards, e.g. vessel overflow through incorrect mounting or adjustment. Damage to property and persons or environmental contamination can result. Also, the characteristics of the instrument can be impaired.

An inappropriately use, disregarding the Operating manual and the technical rules, using under-qualified personnel, making unauthorized alterations as well as damage of the device releases the manufacturer from liability for any resulting damage. This renders the manufacturer's warranty null and void.

2.3. Operational safety

The device is safely built and tested according to state-of-the-art technology. The instrument must only be operated in a technically flawless and reliable condition. The operator is responsible for the trouble-free operation of the instrument. The device may only be used within the permitted operation limits. Every use besides these limits as agreed can lead to serious dangers.

The materials of the device must be checked for compatibility with the respective application requirements before use. An unsuitable material can lead to damage, abnormal behavior or destruction of the device and to the resulting dangers.

The sensors may not be used as sole device for prevention of dangerous conditions in machines and plants.

The maximum transmission output of the sensor is within the approved limit values specified in ETSI EN 305550-2

For safety and warranty reasons, any invasive work on the device beyond that described in the Operating manual may be carried out only by personnel authorized by the manufacturer. Arbitrary conversions or modifications are explicitly forbidden. For safety reasons, only the accessory specified by the manufacturer must be used.

This measuring device meets article 4 (3) of the EU directive 2014/68/EU (pressure equipment device directive) and is designed and produced in good engineer practice.

The device meets the legal requirements of all relevant EU directives. This is confirmed by attaching the CE mark to the device. The associated EU-Declaration of Conformity can be ordered or downloaded from the homepage.

3. Product description

3.1. Function

The device is an electronic radar filling level sensor for continuous measurement of filling levels in liquid media.

The device operates with a pulsed FMCW radar (Frequency Modulated Continuous Wave) and detects contactless the distance to motionless objects.

The sensor outputs a periodic radar signal with linear frequency which varies upwards and downwards. The rate of change of frequency over time remains constant. Objects in the detection range reflect the transmitted signal. The change in the signal delay and frequency of the reflected signal are used to determine the distance to the object.

The device is suitable for applications in virtually all industries, optimally for use within container up to 10m.

Due to the small opening angle especially disturbances by foreign objects or internals will be reduced.

It is advisable for applications, where optical or ultrasonic sensors are unsuitable because of disruptive factors like temperature, gas or dust stratification, under or overpressure resp. vacuum, dust, wind or incidence of light.

The Radar technology allows depending on the application:

- Measurement of liquids, also at gas stratification (e.g. ammonia) or foaming
- Measurement of bulk materials
- Measurement through the container wall, e.g. IPC container or through a protection window, e.g. PTFE or PP

3.2. Construction

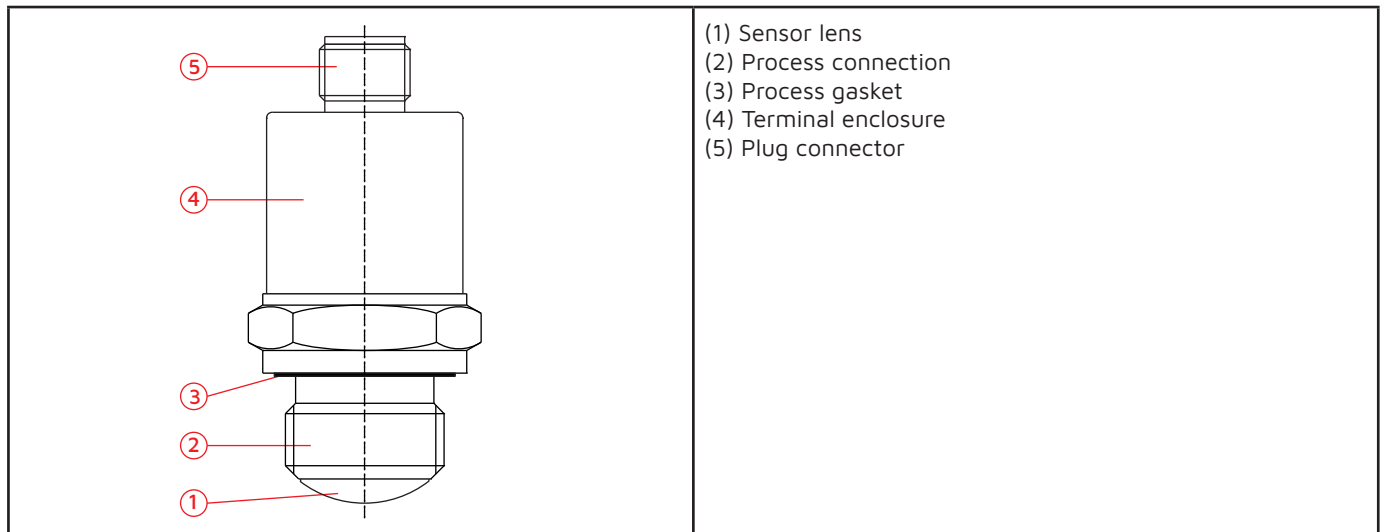

The device is installed into the plant by the process connection (2). The sealing of the process connection against the process is made by a suitable elastomer gasket (3).

The radar signal is radiated resp. received by the sensor lens (1). The signal is captured by the evaluation electronic, that is integrated within the terminal enclosure (4), processed according to the settings and transferred to the outputs at the plug connector (5).

Parameterization and operation of the integrated evaluation electronic can be made by the wired interface.

A laser marking of the product label ensures the identifiability of the device throughout the entire lifetime.

3.3. Product label

The product label contains the most important data for identification and use of the instrument.

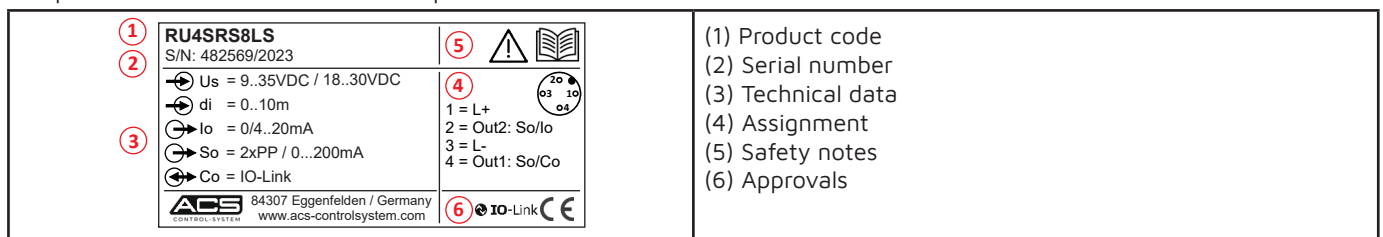

3.4. Product code

RU4 [01][02][03][04][05][06][94][95][98]

01	Application type	S	Standard
02	Sensor	R	Radar FMCW
03	Approval	S	Standard
04	Process connection	9	Thread ISO 228-1 – G½"A, DIN EN ISO 1179-2 E
04		8	Thread ISO 228-1 – G¾"A, DIN EN ISO 1179-2 E
04		5	Thread ISO 228-1 – G1"A, DIN EN ISO 1179-2 E
05	Electronic – Output	V	RS485 Modbus-RTU, 4-wire
05		L	IO-Link, current 0/4...20mA / 2x Sout PP, 4-wire
06	Electrical connection	S	PlugM12-A-4P

94	Additional option	-SF	LABS-free, silicone-free / paint compatible version
95	Additional option	-ML	Measurement point designation / TAG – Laser marking
98	Additional option	-KF	Configuration / Preset

Differing versions are normally marked by the character Y at the product code.

3.5. Dimensions

Dimensions in mm

The parameter d_i characterizes the distance measuring value with the corresponding measuring reference point.

Thread ISO 228-1 – G1/2", ISO 1179-2 E [04-9]	Thread ISO 228-1 – G3/4", ISO 1179-2 E [04-8]
Process pressure $P_{max} = -1...10$ bar Torque $M_{max} = 50$ Nm	Prozessdruck $P_{max} = -1...10$ bar Torque $M_{max} = 50$ Nm

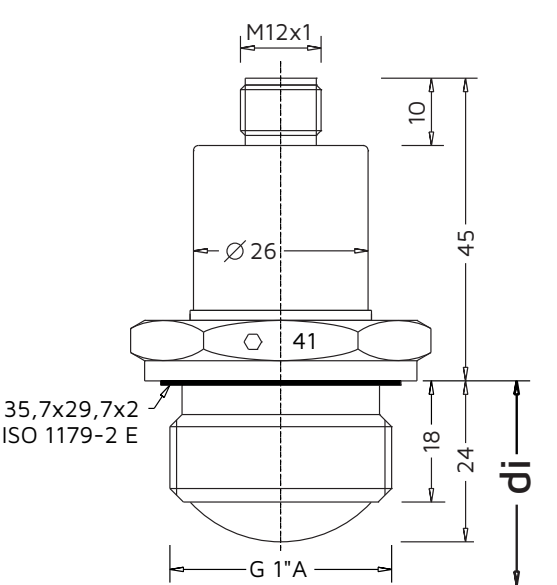
Thread ISO 228-1 – G1", ISO 1179-2 E [04-5]	
Process pressure $P_{max} = -1...20$ bar Torque $M_{max} = 50Nm$	
	

3.6. Packaging, transport, storage

The device is protected by packaging. It can handle normal loads during transport. Transport must be carried out in due consideration of the notes on the transport packaging. Nonobservance of these instructions can cause damage to the device.

The delivery must be checked for completeness and possible transit damage immediately at receipt. Ascertained transit damage or concealed defects must be appropriately dealt with.

Up to the time of installation, the packages must be left closed and, unless otherwise indicated, must be stored only under the following conditions:

- Not in the open
- Dry and dust free
- Not exposed to corrosive media
- Protected against solar radiation
- Avoiding mechanical shock and vibration
- Storage and transport temperature $-20...+85^{\circ}C$
- Relative humidity 20...85%

3.7. Accessories

For installation and electrical connection an extensive portfolio, that is optimally matched to the device is available:

- Welding sockets
- Reduction adapter
- Gaskets
- Connection cables
- Confectionable connection jacks
- RS-485 interface converter
- IO-Link Master

4. Installation

4.1. Ambient and process conditions

The correct function of the device within the specific technical data can only be guaranteed, if the permitted ambient and process conditions at the installation place (» chapter Technical Data) will not be exceeded. Hence make sure before mounting that all parts of the instrument exposed to the process (e.g. sensor lense, process connection, process gasket) are suitable for the existing process conditions (e.g. process pressure, process temperature, chemical properties of the medium, abrasion, mechanical influences).

The quality of the measuring result depends significantly on the characteristics of the measured media:

- Liquid media up to a DK value ≥ 4 can be detected.
- Through the action of filling, stirring and other processes in the vessel, dense foams which considerably damp the emitted signals may form on the product surface.
- Reduction of the maximum possible measurement range by media with bad reflection characteristics, build-up forming, strong condensation, foaming or icing of the sensor.

4.2. Installation place

The distance measuring value refers to the measurement reference point (» chapter Product description - Dimensions).

Within the range of the blind zone (minimum measuring range » chapter Technical Data) no object detections takes place.

The sensor can be installed in any direction.

Use short connection pieces to ensure unhindered signal propagation in the short range.

Plastics are normally transparent for radar beams. Thus at plastic container, e.g. IPC container a surface installation without damaging the container wall ist possible. Additionally possible isa measruement through a protection wall, e.g. PTFE, PP at high temperatures or aggressive media. Special materials, e.g. glas or admixtures of glas or carbon fibre or graphite can impede or prevent the measurement through the wall.

If the outer wall of the container consists of a non conductive material (e.g. plastik, GRP), microwaves can be also reflected by outside installed attachments (e.g. metallic tubes, ladders, grids, etc.). Thus also outside the container there should not be such parts within the beam cone.

Multiple radar sensors can be installed besides without interact each other.

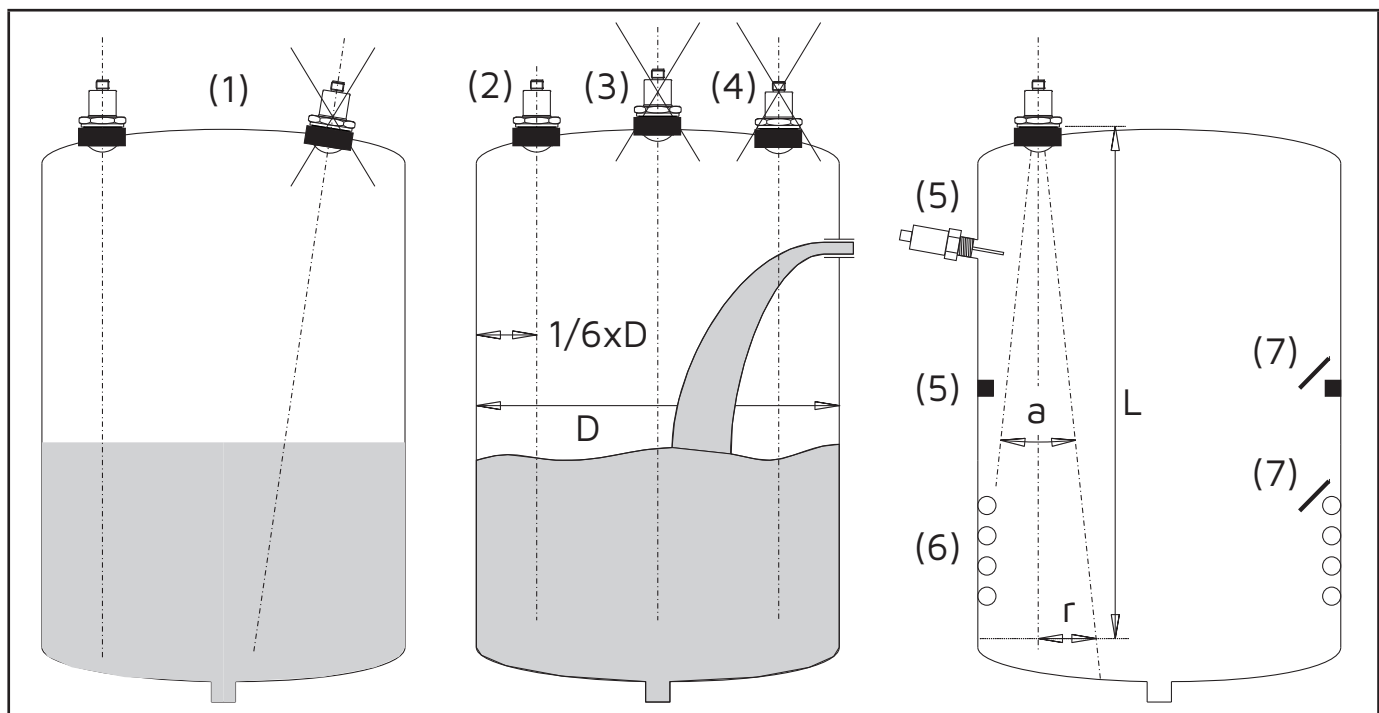

(1) The sensor must be installed vertically to the filling media surface.

(2) The recommends installation distance to the container wall is $1/6$ of the container diameter.

(3) The sensor should not be mounted in the middle of the container.

(4) A measurement through the filling curtain must be avoided.

(5) Avoid installations like limit switches or temperature sensors within the detection range.

(6) Symmetrical equipment such as heating coils or baffles can influence measurement especially.

(7) Interferring reflections from components can be strayed or reduced by diagonal installed metallic sheets.

The radius r of the detection range at distance L at opening angel a (» chapter Technical Data) can be calculated with the following term: $r = \tan(a / 2) * L$

4.3. Standpipe

The use of a standpipe can considerably improve the signal quality.

It is recommended at container installations resp. very uneven shaft walls, at foam construction, at moved surfaces and at low DK values.

The standpipe should be of metall or plastic with graphite or carbon fibre admixture.

For filling media, that tend to strong adhesions, the measurement with standpipe is not reasonable, if so the tube must be periodically cleaned.

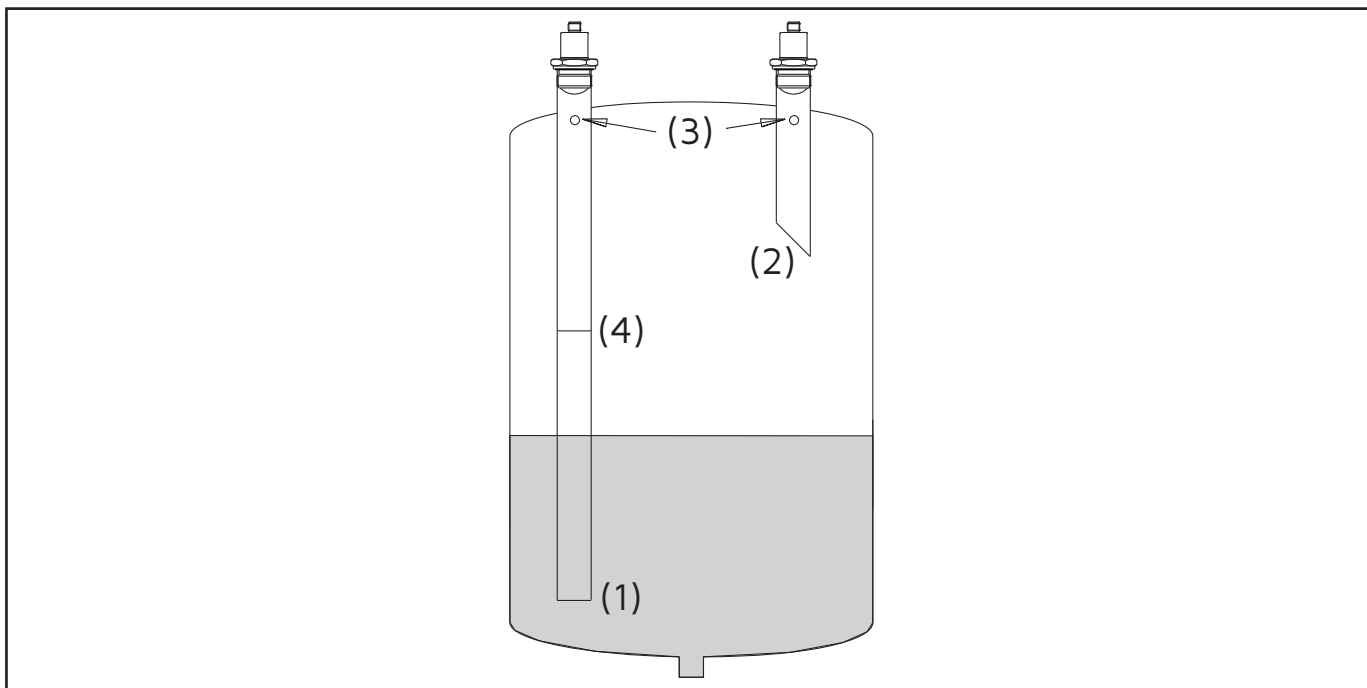

(1) Standpipes must reach deeper than the minimum filling level.

(2) At shorter tubes the medium sided tube end must be cut diagonal (45°).

(3) A venting hole (Ø 5...10mm) in the blind zone, above the maximum filling level must be provided.

(4) Large gaps and thick welding joints inside the tube when connecting the tubes must be avoided.

4.4. Installation notes

WARNING	Install the device only when the system is pressureless. There is a risk of fast escaping media resp. pressure blow.
----------------	--

WARNING	Let the system cool down sufficiently before installing the device. There is a risk of dangerous and hot media escaping.
----------------	--

Do not remove packaging until just before mounting and check the device for any damage.

The protective cap, which is attached at the process connection resp. the sensor lense, must only be removed immediately before the installation. The sensor lense may not be damaged.

Sealing faces and threads at the device and at the installation point must be clean and without damage.

Parallel threads must be sealed by a suitable O-ring, flat or profile gasket. An additional sealing material such as yam, hemp or PTFE tape should not be used. Tapered threads should be wound with additional sealing material, e.g. PTFE tape for sealing.

The tightening of the thread process connection may only be done at the hexagon by a suitable spanner at most with the maximum permitted torque strength (» chapter Product description - Dimensions).

5. Electrical connection

5.1. Electronic output [05-V] – RS485 Modbus-RTU

5.1.1. Function

The Modbus protocol is a communication protocol, that base on a master/slave architecture. All devices are connected by two data wires (A+ / B-) and by one COMMON-wire (C/L-).

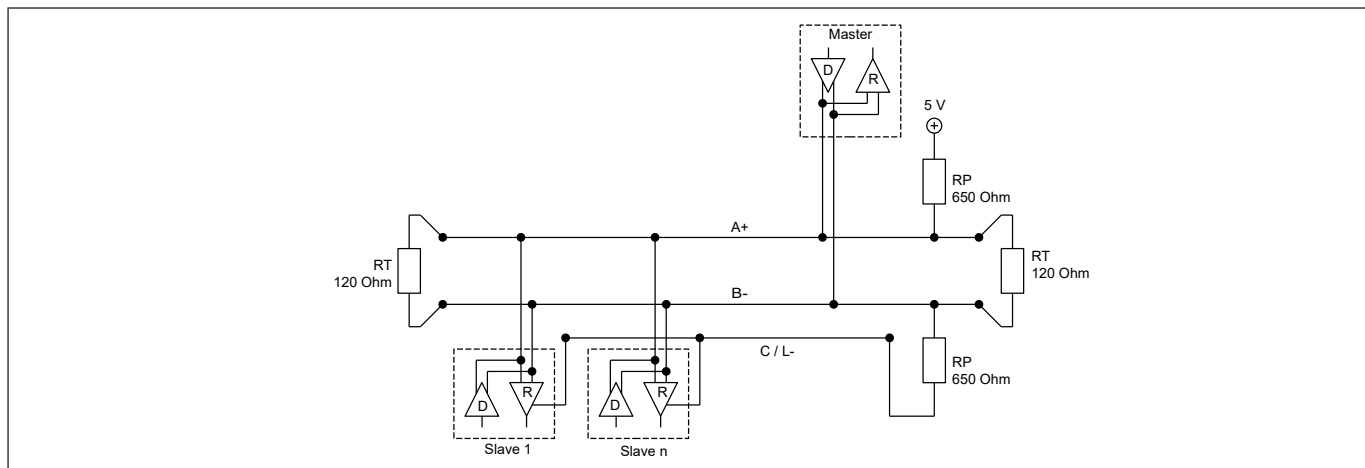

An original RS485 allows the connection of 32 slaves within one segment. The device has a load of only 1/8 of the standard load ($R_{in} \geq 96 \text{ k}\Omega$), thus up to 256 of the devices can be theoretically operated within one network segment. However the number is limited to 247 due to the Modbus address space.

The both termination resistors RT prevent reflections on the data wires. The optimum resistor value depends on the wave impedance of the used cable, but a value of 120 Ohm is a popular choice.

The polarisation network is necessary, to ensure suitable potentials, if none of the devices transmits and thus the wires A+ and B- are undefined (high impedance). The value for RP depends e.g. on bus load or the termination resistors. Recommended values are between 450 Ohm and 650 Ohm.

The use of a polarisation network is recommended, to ensure a stable network. Usually the polarisation resistors are implemented within the master device or they are connectible.

Connect the device at bus topology (line). A stub line must be avoided.

5.1.2. Terminal assignment

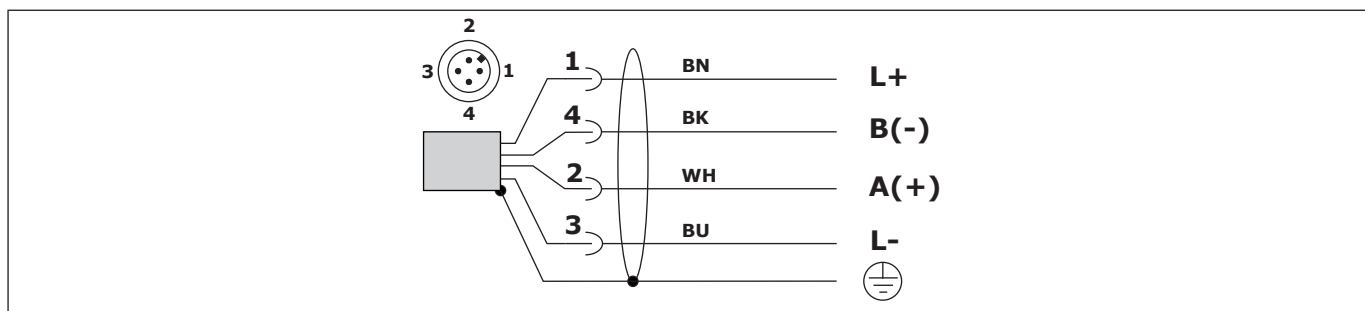

5.1.3. Connection cable

Cable: M12 – A-coded, 1-BN = brown / 2-WH = white / 3-BU = blue / 4-BK = black

Use a cable 4-core acc. to the EIA485 recommendations:

Impedance	135...165Ω @ 3...20Mhz
Cable capacity	< 30pF/m
Cable diameter	> 0,64mm
Cable cross section	0,34 mm ² / AWG 22
Loop resistance	< 110Ω/km
Shielding	Braided shield /shield foil
Cable length	38400 Baud ≤ 1200m

5.1.4. Connection notes

WARNICG	Install the device only in de-energized state.
NOTE	For start-up deactivate all connected control devices, to avoid unwanted control reactions.

Observe maximum permitted supply voltage U_s at the terminals L+/L-:

- $U_s = 6...35VDC$

The device must be grounded, preferred by the metallic process connection, alternatively by the cable shield.

Install cable separated from power leading cables, if existing connect shield to earth.

5.2. Electronic Output [O5-L] - IO-Link

5.2.1. Function

IO-Link is a worldwide standardized I/O technology to communicate with sensors. It is a serial bidirectional point-to-point connection.

The IO-Link communication requires an IO-Link-Master.

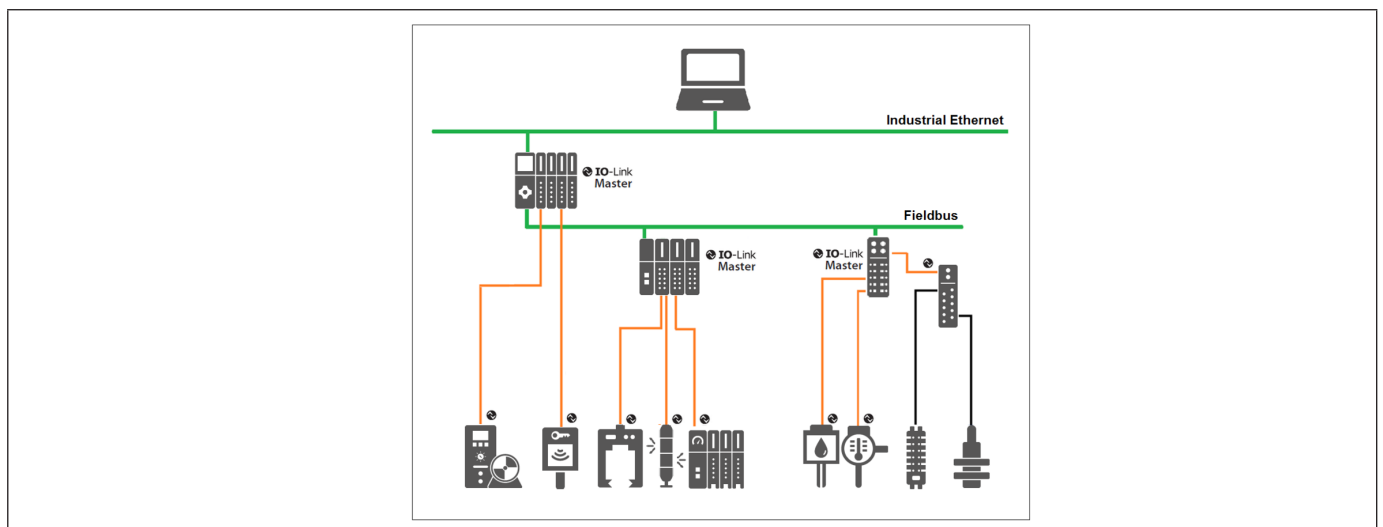

5.2.2. Terminal assignment

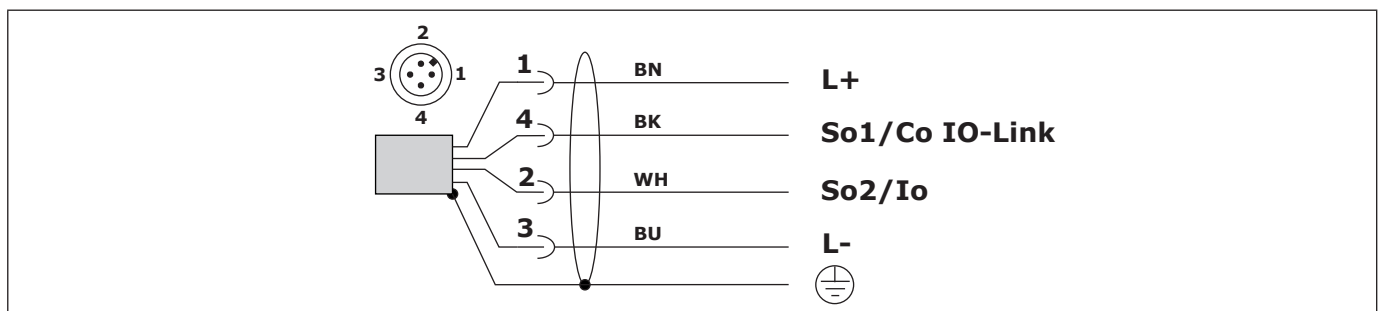

5.2.3. Connection cable

Cable: M12 – A-coded, 1-BN = brown / 2-WH = white / 3-BU = blue / 4-BK = black

Use a cable max. 20m, 3- resp. 4-core, unshielded.

When using the analogue output, a shielded cable must be used.

5.2.4. Connection notes

WARNIGG	Install the device only in de-energized state.
NOTE	For start-up deactivate all connected control devices, to avoid unwanted control reactions.
NOTE	Inductive loads at the switch outputs, e.g. contactors or magnetic vents may only be used with a free-wheeling diode or a RC protection circuit.

Observe maximum permitted supply voltage U_s at the terminals L+/L-:

- $U_s = 9...35VDC$
- $U_s = 18...30VDC$, IO-Link

Observe maximum permitted load resistor R_L of the analogue output:

- $R_L \leq (U_s - 8V) / 22mA$

The device must be grounded, preferred by the metallic process connection, alternatively by the cable shield.

Install cable separated from power leading cables, if existing connect shield to earth.

<p>Out1 – IO-Link Out2 – Current 0/4...20mA</p> <p>L+ Co IO-Link Io mA L-</p>	
<p>Out1 – IO-Link Out2 – Switch p-switching</p> <p>L+ Co IO-Link So2 PNP L-</p>	<p>Out1 – IO-Link Out2 – Switch n-switching</p> <p>L+ Co IO-Link So2 NPN L-</p>
<p>Out1 – Current 0/4...20mA Out2 – Switch p-switching</p> <p>L+ So1 PNP Io mA L-</p>	<p>Out1 – Current 0/4...20mA Out2 – Switch n-switching</p> <p>L+ So1 NPN Io mA L-</p>
<p>Out1 – Switch p-switching Out2 – Switch p-switching</p> <p>L+ So1 PNP So2 PNP L-</p>	<p>Out1 – Switch n-switching Out2 – Switch n-switching</p> <p>L+ So1 NPN So2 NPN L-</p>

6. Operation

Parameterization and operation can be made by the electronic variant dependent integrated wired interface. Knowledge concerning the communication technology is provided.

Measurand

The sensor is able to output either the measurand distance or fill level, see picture below - left.

Filter

The signal filter allows to define the correct measuring signal

- Jumpy: the first valid indicated signal is used >> Picture below - right (1)
- Max. value: the strongest/highest signal is used >> Picture below - right (2)
- Interference suppression: Only signal changes, slower than set, are output.

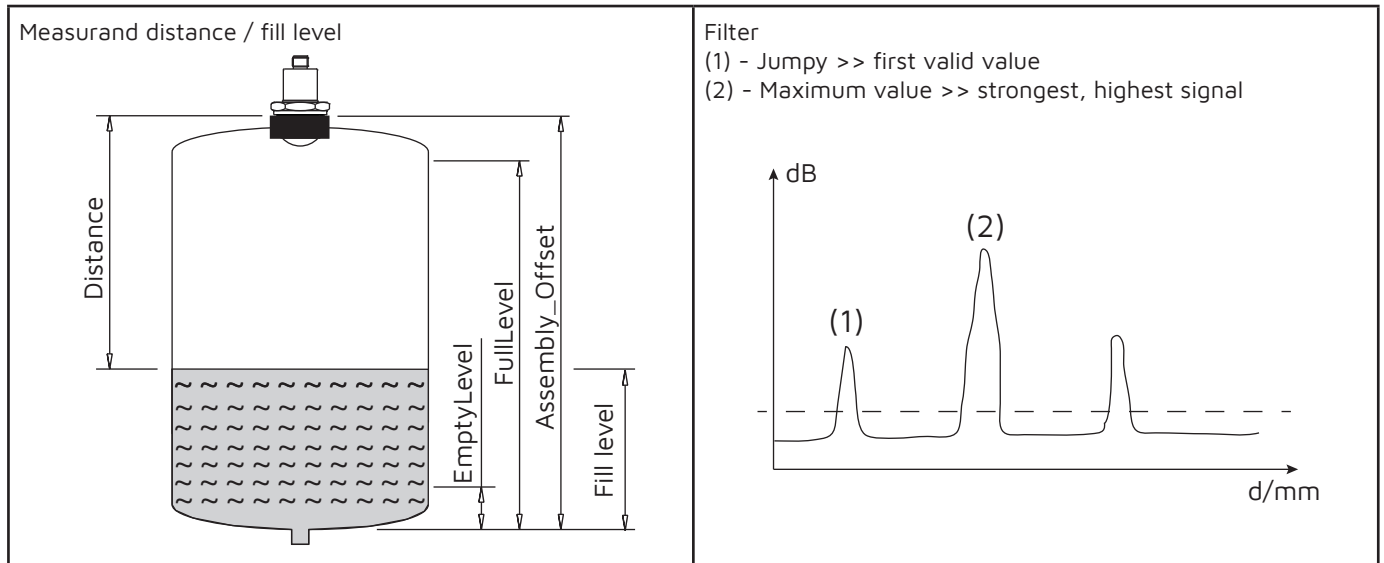

6.1. Electronic output [05-V] – RS485 Modbus-RTU

The operation of the device is made exclusively by the wired interface and the operating software.

Information's for installation und using the RS485 interface and operating software are not content of this manual.

Abbreviation	Description	Measurand
PV	Primary value	Distance / Fill level
SV	Secondary value	Signal strength

Function code	Register type
03	Read Holding Register
04	Read Input Register
06	Write Single Register
16	Write Multiple Register

Device settings - Holding Register

Address	Register name	Byte / Type	Default	Description
2000	Address	2 / UInt16 - r/w	1	Modbus ID / 1 ... 247
2001	Baud-Rate	2 / UInt16 - r/w	3	0 = 1200 / 1 = 2400 / 2 = 4800 / 3 = 9600 4 = 19200 / 5 = 38400 / 6 = 57600 / 7 = 115200
2002	Parity	2 / UInt16 - r/w	2	0 = None / 1 = Odd / 2 = Even
2003	Stopbits	2 / UInt16 - r/w	0	0 = 1 Stop Bit / 1 = 2 Stop Bit
2004	Byte Order	2 / UInt16 - r/w	0	0 = ABCD / 1 = CDAB

Device settings - Input Register

Address	Register name	Byte / Type	Default	Description
1000	Device Type	2 / UInt16 - r		
1001	Serial Number	4 / UInt32 - r		
1003	Calibration Date	2 / UInt16 - r		
1004	Hardware Version	2 / UInt16 - r		
1010	ReportedLimit_Upper PV	4 / Float - r		Min. possible measuring value distance/fill level
1012	ReportedLimit_Lower PV	4 / Float - r		Max. possible measuring value distance/fill level

Measurand - Holding Register

Address	Register name	Byte / Type	Default	Description
2020	Damping PV	2 / UInt16 - r/w	1000	Unit ms / Damping meas. value distance/fill level exponentially / value x 0,01s = 99,9% meas. value
2050	Operation Mode	2 / UInt16 - r/w	0	0 = Measurand distance 1 = Measurand fill level
2051	Filter	2 / UInt16 - r/w	2	0 = Max. value: strongest/highest signal 1 = Jumpy: the first valid indicated signal 2 = Interference suppression >> LevelChangeSpeed
2052	EchoLost	2 / UInt16 - r/w	0	Behaviour at signal lost: 0 = Hold last value 1 = Distance 0 [Unit] 2 = Maximum fill level 3 = Minimum fill level
2053	MeasureInterval	4 / UInt32 - r/w	100	Measuring intervall / Unit ms
2055	EmptyLevel	4 / Float - r/w	0	Measured value fill level: minimum fill level [Unit]
2057	FullLevel	4 / Float - r/w	10	Measured value fill level: maximum fill level [Unit]
2059	Assembly_Offset	4 / Float - r/w	10	Measured value fill level: assembly offset [Unit]
2067	LevelChangeSpeed	4 / Float - r/w	1	Unit m/s / Filter type 2 – permitted signal change
2077	Command	2 / UInt16 - w		1 = Store changed values 2 = Store default values 3 = Reset

Measuring value - Input Register

Address	Register name	Byte / Type	Default	Description
1100	Status	2 / UInt16 - r		Bit 0: 0 = meas. value distance/fill level is valid Bit 0: 1 = meas. value distance/fill level is invalid Bit 1: 0 = meas. value signal strength is valid Bit 1: 1 = meas. value signal strength is invalid
1101	Unit PV	2 / UInt16 - r	[Unit]	Code 45 = Unit m Code 49 = Unit mm Code 57 = Unit percent %
1102	Measure Value PV	4 / Float - r		Measuring value distance/fill level
1104	Unit SV	2 / UInt16 - r	dB	Unit of measuring value signal strength (code 156)
1105	Measure Value SV	4 / Float - r		Measuring value signal strength

6.2. Electronic output [05-L] – IO-Link

The operation of the device is made exclusively by the wired interface and the operating software.

Information's for installation und using the IO-Link-Master and operating software are not content of this manual.

The IODD parameter file and description can be downloaded from the homepage www.acs-controlsystem.com.

The IODD description contains the adjustment ranges and default values of the parameter.

6.2.1. Parameter

Measurand

Parameter	r/w	Description
DisplayModus	rw	Distance / Fill level
Assembly_Offset	rw	Measured value fill level: Assembly offset
EmptyLevel	rw	Measured value fill level: minimum fill level
FullLevel	rw	Measured value fill level: maximum fill level
Filter	rw	Jumpy: the first valid indicated signal will be used Fast 0,5m/s: very fast signal steps will be ignored Slow 1m/s: fast signal steps will be ignored Maximum value: strongest/highest signal will be used
EchoLost	rw	Behaviour at signal lost: hold / Distance 0m / max. fill level / min. fill level
MeasureInterval	rw	Measuring intervall / Unit ms

Measuring settings

Parameter	r/w	Description
Unit	rw	Unit of the measuring value
TeachZero	rw	Measuring value offset / Characteristic curve shift / Unit acc. to parameter [Unit]
Damp1	rw	Damping measuring value / exponentially / value x 0,01s = 99,9% measuring value
ReportedLimit_Lower	r	Minimum possible measuring value / Unit acc. to parameter [Unit]
ReportedLimit_Upper	r	Maximum possible measuring value / Unit acc. to parameter [Unit]
User_Button	w	Delete Peak_min / Peak_max / Peak_min+max / Offset adjustment to meas. value
User_DAC_mA	rw	Analogue output current value / currently output or simulation / Unit mA
Transducer limit underrun	r	Counter / Sensor limit underrun
Transducer limit overrun	r	Counter / Sensor limit overrun

Measuring value

Parameter	r/w	Description
Lin. Measure + Zerooffset	r	Measuring value/ shift by zero offset / Unit acc. to parameter [Unit]
Signal	r	Signal strength of measuring value / Unit dB
Analog out	r	Output value analogue output / Unit mA
Peak_max	r	Maximum stored measuring value / Unit acc. to parameter [Unit]
Peak_min	r	Minimum stored measuring value / Unit acc. to parameter [Unit]

6.2.2. Switch output So

Operation Mode

Depending on the operation mode [O1_Conf/O2_Conf+Operation Mode], the output will be switched differently:

- PP (Push-Pull) Auxiliary supply voltage +L <--> Auxiliary supply voltage -L
- NPN Auxiliary supply voltage -L <--> off - high-impedance
- PNP Auxiliary supply voltage +L <--> high-impedance
- Analog Out Current output I_o 0/4...20mA

For the switch output So1 only the operation mode PP can be selected.

Switch Mode

For the switch outputs different switch modes [O1_Conf/O2_Conf+Switch Mode] can be selected:

Deactivated

The switch output is deactivated and thus high-impedance.

Single Point Mode

The switch output is activated, if the measuring value overrides the switch point [O1_SP/O2_SP] and the switch on delay time [O1_dS/O2_dS] is expired.

The switch output is deactivated, if the measuring value fall below the switch point [O1_SP/O2_SP] and the switch off delay time [O1_dR/O2_dR] is expired.

At polarität [O1_Conf/O2_Conf+Polarity+NO] the reset point is lower by the hysteresis [O1_HY/O2_HY] than the set switch point [O1_SP/O2_SP].

At polarität [O1_Conf/O2_Conf+Polarity+NC] the effective switch point is higher by the hysteresis [O1_HY/O2_HY] than the switch point [O1_SP/O2_SP].

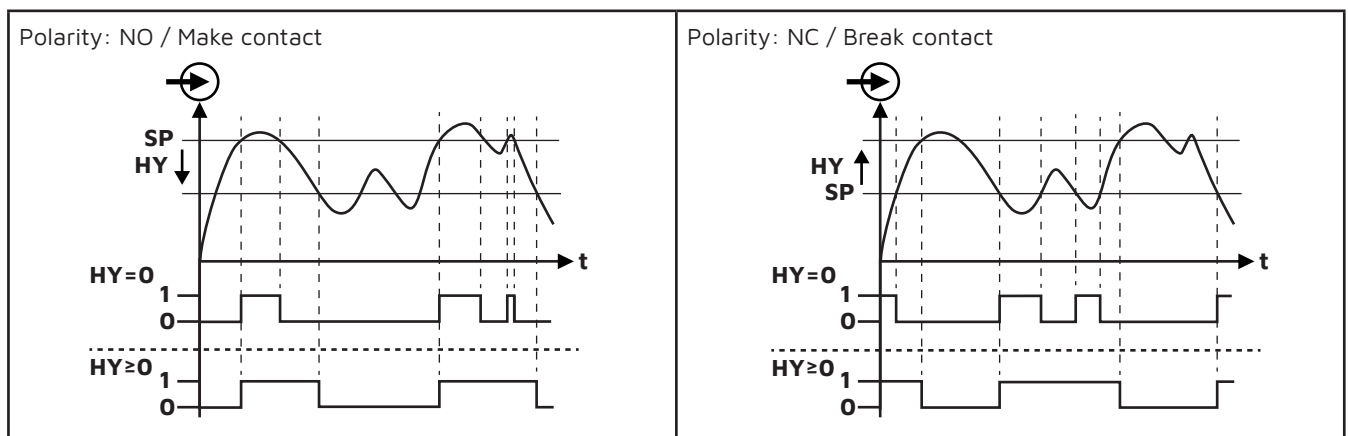

Window Mode

The switch range is determined by specification of switch point [O1_SP/O2_SP] and reset point [O1_RP/O2_RP].

The switch output is activated, if the measuring value is within the range, defined by switch point [O1_SP/O2_SP] and reset point [O1_RP/O2_RP] and the switch on delay time [O1_dS/O2_dS] is expired.

The switch output is deactivated, if the measuring value is outside the range, defined by switch point [O1_SP/O2_SP] and reset point [O1_RP/O2_RP] and the switch off delay time [O1_dR/O2_dR] is expired.

The hysteresis [O1_HY/O2_HY] generates a switch offset symmetrically at switch point [O1_SP/O2_SP] and at reset point [O1_RP/O2_RP].

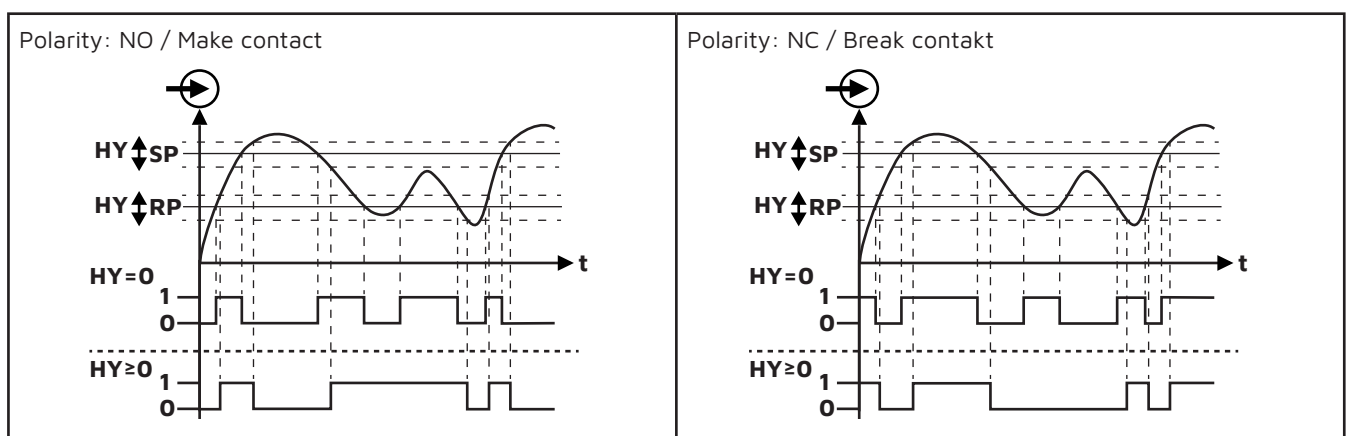

Two Point Mode Mode

The switch range is determined by specification of switch point [O1_SP/O2_SP] and reset point [O1_RP/O2_RP].

The switch output is activated, if the measuring value overrides the switch point [O1_SP/O2_SP] and the switch on delay time [O1_dS/O2_dS] is expired.

The switch output is deactivated, if the measuring value fall below the switch point [O1_SP/O2_SP] and the switch off delay time [O1_dR/O2_dR] is expired.

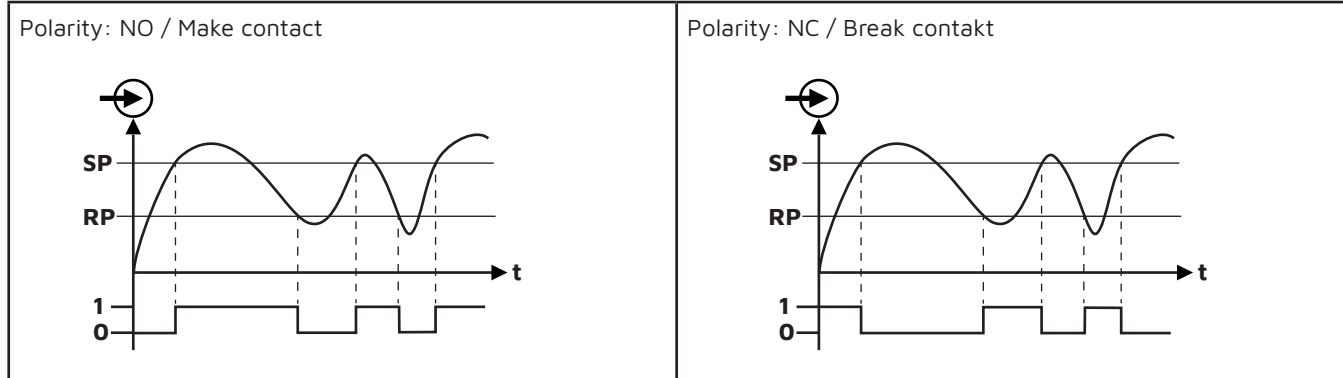

Error indication function

The switch output indicates a detected functional error (» chapter Errordiagnosis and Troubleshooting)

6.2.3. Analogue output I_o

An analogue current signal is generated, that is referred to the nominal measuring range of the device:

- 0 – 20 mA output signal range 0...20,5mA
- 4 – 20mA output signal range 3,8...20,5mA
- 20 – 0 mA output signal range 20,5...0mA
- 20 – 4 mA output signal range 20,5... 3,8mA

A free assignment to measuring input values in the range of the nominal measuring range is possible.

Behaviour of the output current values at overriding the output signal range acc. to Namur NE43:

- (1) Hold end value 0/3,8mA/20,5mA
- (2) Step $\leq 3,6$ mA
- (3) Step ≥ 21 mA (22mA)

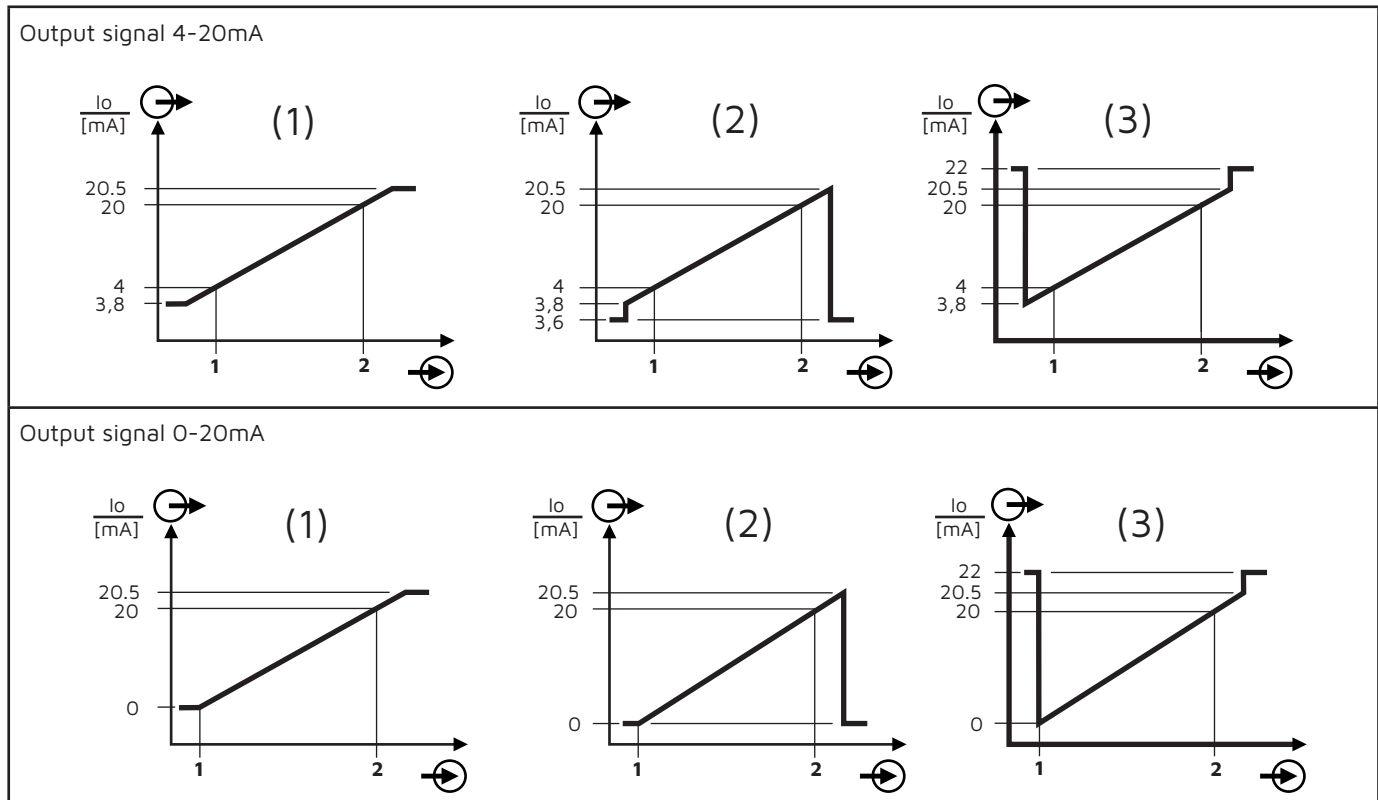

7. Error diagnosis and Troubleshooting

The operator of the system is responsible for taking suitable measures to rectify faults.

Error indication Electronic output [05-L] – IO-Link:

IO-Link Code	Description	Troubleshooting
20480 (0x5000)	Error device hardware	Replace device or send in for repair
35856 (0x8C10)	Override measuring range	Check adjustment measuring range
35888 (0x8C30)	Underrun measuring range	Check adjustment measuring range
36346 (0x8DFA)	Analogue output error 3,6mA	Check adjustment current output
36347 (0x8DFB)	Analogue output error 22mA	Check adjustment current output

In case of malfunction check:

Component / area	Check	Troubleshooting
Enclosure	Damage	Replace device or send in for repair
Sensor lens	Pollution	Clean device or send in for repair
	Damage	Replace device or send in for repair
Process gasket	Damage	Replace process seal
		Use other seal material if necessary
Supply voltage	Operating voltage available	Switch-on resp. repair operating voltage
		Check terminals resp. repair
	Operating voltage reverse connected	Reverse operation voltage connection
	Operating voltage too low / too high	Adapt resp. repair
	Load resistance too high	Reduce resistance
		Increase operating voltage
	Connection cable damaged	Change resp. repair cable

If the malfunction cannot be eliminated, please contact the manufacturer.

8. Maintenance

At appropriate use, the device is free of maintenance.

Solid coatings on the sensor lens can lead to faulty measurement results. In this case the sensor lens must be regularly cleaned. Don't use sharp resp. hard tools, pressured air or aggressive chemicals.

9. Repair

The device is not intended for repair by the user. A repair may only be carried out by the manufacturer.

9.1. Dismounting

Use suitable protective clothing, e.g. goggles, gloves.

WARNING	Let the device and the system cool down sufficiently fore dismounting it. There is a risk of hot surfaces as well as dangerous and hot media escaping.
----------------	--

WARNING	Dismount the device only when the system is pressureless. There is a risk of fast escaping media resp. pressure blow.
----------------	---

After dismounting, the sensor lens / process connection and the connection plug must be provided with a protection cap.

9.2. Return

Returns can only be accepted if the device has been equipped with a Decontamination declaration enclosed. The decontamination declaration is available at <https://www.acs-controlsystem.com> at the download area and must be completely filled in, and affixed securely and weather-proof to the outside of the packaging.

9.3. Disposal



As required by the Directive 2012/19/EU on waste electrical and electronic equipment (WEEE), products of ACS are marked with the depicted symbol in order to minimize the disposal of WEEE as unsorted municipal waste. Such products may not be disposed of as unsorted municipal waste and can be returned to ACS for disposal.

The return follows the conditions stipulated in the General Terms and Conditions or as individually agreed by ACS.

10. Technical Data

Reference conditions	Ta = +15°C..+25°C (+59°F..+77°F) / pa = 860..1060kPa / r.F. = 45..75% ton = 240s / Us = 24VDC±0,1V
Measurement deviation	EN/IEC 60770-1: Characteristic deviation – Limit value adjustment

10.1. Input distance

Sensor type	FMCW radar, pulsed
Frequency	122...123 GHz
Radiated Power EIRP	≤ 10dBm
Opening angle	[04-9]: 10° / [04-8]: 8° / [04-5]: 8°
Pulse rate	≥ 10Hz / ≤ 100ms
Measuring range	0 ... 10m (FSI)
Blind zone	≤ 30cm
Resolution	≤ 1mm
Characteristic deviation	≤ ±0,1%FSI (Linearity + Reproducibility + Hysteresis)
Linearity	≤ ±0,1%FSI
Reproducibility	≤ ±2mm
Hysteresis	negligible
Influence supply voltage	≤ ±0,002%FSI/V
Influence temperature	≤ ±0,005%FSI/K
Long term drift	≤ ±0,02%FSI/Jahr
Influence mounting pos.	without

10.2. Electronic output [05-V] – RS485 Modbus-RTU

Interface - Co	
Specification	RS485, bidirektional / Modbus-RTU / 4,8...38,4 kBaud
Input resistor	112kΩ
Time behaviour t90-min	≤ 100ms (td = 0s)
Auxiliary power	
Supply voltage Us	6...35VDC reverse polarity protected / Ripple voltage ≤ 2Vpp
Input current Is	≤ 20mA (Co = 0mA)
Ready delay time	≤ 0,5s (td = 0s)

10.3. Electronic output [05-L] – IO-Link

Interface - Co	
Specification	IO-Link V1.1 / Port Class A / Com2 (38,4 kBaud), Com3 (230,4 kBaud)
Cycle time	≥ 2,3ms
Time behaviour t90-min	≤ 100ms (td = 0s)
Switch output - So	
Specification	2x PP (Push-Pull), switch to +L/-L
Output signal Uo	≤ 0,2V...≥ (Us - 2V) / Io = 0...200mA (current limited ≤ 450mA, short circuit protected)
Switch delay time	≤ 30µs (RL ≤ 3kR / Io ≥ 4,5mA)
Switch cycles	≥ 100.000.000
Analogausgang – Io	
Signal range	4...20mA: signal range 3,8...20,5mA, error ≤ 3,6mA / ≥ 21mA (22mA) 0...20mA: signal range 0...20,5mA, error ≤ 0,05mA / ≥ 21mA (22mA)
Resolution	≤ 1µA
Permitted load RL	≤ (Us - 8V) / 22mA
Influence supply voltage	≤ ±0,5µA/V
Influence temperature	≤ ±0,5µA/K

Auxiliary power	
Supply voltage U_s	IO-Link inactive: 9...35VDC reverse polarity protected / Ripple voltage $\leq 2V_{pp}$ IO-Link active: 18...30VDC reverse polarity protected / Ripple voltage $\leq 2V_{pp}$
Input current I_s	$\leq 20mA$ ($I_{Co} / I_{So} / I_{Lo} = 0mA$)
Ready delay time	$\leq 0,5s$ ($t_d = 0s$)

10.4. Process conditions

Process temperature T_p	-40...+85°C (-40°F...+185°F)
Process pressure	[04-9]: $\leq -1...10bar$ / [04-8]: $\leq -1...10bar$ / [04-5]: 0,15kg $\leq -1...20bar$

10.5. Environmental conditions

Ambient temperature T_a	-40...+85°C (-40°F...+185°F)
Protection level	IP69K/IP67 (EN/IEC 60529)
Climatic classification	4K4H (EN/IEC 60721-3-4)
Shock classification	50g [1ms] (EN/IEC 60068-2-27)
Vibration classification	20g [10...2000 Hz] (EN/IEC 60068-2-6)
EM compatibility	Operation device class B / Industrial range (EN/IEC 61326)
Insulation voltage	500Vac
Protection class	III
Pollution degree	4
Altitude above sea level	2000m above sea level
MTTF	[05-V]: 213 years / [05-L]: 214 years
Weight	[04-9]: 0,08kg / [04-8]: 0,10kg / [04-5]: 0,15kg

10.6. Materials

Process wetted	Steel1.4404/316L, PEEK, FKM/FPM
Not process wetted	CrNi-steell, PUR, FKM/FPM

11. Revision

Version	Changes
BA03.23	Original version
BA05.23	1.2. Terms - Addition variant 2.3. Operational safety - Addition PDE 6.1. Operation - Rework IO-Link 10.5. Environmental conditions - Correction MTTF
BA06.23	6. Operation - Addition RS485 Modbus-RTU / Rework IO-Link



FEEL FREE TO
CONTACT US

ACS-CONTROL-SYSTEM GmbH
Lauterbachstr. 57
84307 Eggenfelden - Germany
info@acs-controlsystem.de
www.acs-controlsystem.com
+49 (0) 8721-9668-0