

Technical manual BA 0419



Filling level



SLK Electrode probe

for conductive limit level detection
in electrical conductive liquids

Detects up to four limit values simultaneously

Useable

- for leakage or overflow protection in container
- for minimum, maximum resp. multilevel detection in container
- as pump protection, resp. dry run protection in pipelines
- for two-position-control of pumps

Wide application range

- for conductivities higher than 1 $\mu\text{S}/\text{cm}$
- for process temperatures from $-40\text{ }^{\circ}\text{C}$ to $+130\text{ }^{\circ}\text{C}$
- for process pressures from -1 bar to $+20\text{ bar}$
- materials also for aggressive filling material

ATEX II 1 G Ex ia IIB/IIC T6...T1 Ga

Certification for the use in explosion hazardous areas

Integrated wire break monitoring

ACS-CONTROL-SYSTEM
know how mit system



Lauterbachstr. 57 – 84307 Eggenfelden – Germany
Tel: +49 8721/9668-0 – Fax: +49 8721/9668-30
info@acs-controlsystem.de – www.acs-controlsystem.de

Index

Application field	3
Function	3
Safety notes	4
Safety notes 	4
Installation	5
Maintenance	5
Repair	6
Electrical connection	6
Technical data	7
Dimension drawings	8 / 9
Order code overview	10

Application field

The electrode probe **SLK**, in combination with a suitable evaluation device, is used for conductive limit value detection in electrically conductive filling materials.

Depending on the application, the electrode rods can have a length of up to 3 m.

With up to four contact electrodes multiple tasks can be fulfilled simultaneously. Among these tasks are e.g. leakage and overflow protection, minimum / maximum protection resp. multilevel detection in container, pump protection in pipelines and also the two-position-control of pumps.

The electrode probes are designed for a wide application range.

The conductivity also of aggressive filling materials, with 1 $\mu\text{S}/\text{cm}$ and higher can be detected, at process temperatures from $-40\text{ }^{\circ}\text{C}$ to $+150\text{ }^{\circ}\text{C}$, at pressures from -1 bar to +20 bar.

The electrode probes are certificated for the use in explosion hazardous areas acc. to ATEX II 1 G in zone 0.

Function

The electrode probe is mounted directly in the wall of the container or of the pipe by using the respective process connection or installed over the filling material by using a suitable mount.

The alternating voltage, that is generated by a suitable evaluation electronic is applied either between the electrode rods or between the electrode rods and the metallic wall of the container resp. pipe that is connected to the metallic process connection.

As soon as the electrically conductive filling material makes a connection between the electrodes resp. between the electrode and the metallic wall of the container resp. pipe, an measurable current flows, that causes a reaction of the connected evaluation device.

Due to the use of a alternating voltage the corrosion at the electrode and the electrolytic decomposition of the filling material is avoided.

At the electrode probes an additional module (diode module LBM) for the wire supervision can be installed inside the housing.

In the case of a wire break between electrode probe and a suitable evaluation device, the evaluation device can output a corresponding warning signal.

Safety notes

Operational safety

The device is safely built and tested according to state-of-the-art technology and has left the factory in perfect condition as regards technical safety.

The device meets the legal requirements of all relevant EC directives. This is confirmed by attaching the CE mark.

Installation, connection, commissioning, operation

Installation, electrical connection, commissioning and operation of the device must be made by a qualified and authorized expert according to the information's in this technical manual and the relevant standards and rules. This expert must have read and understood this technical manual and especially the safety notes.

The device may only be used within the permitted operation limits that are listed in this technical manual. Every use besides these limits as agreed can lead to serious dangers.

The materials of the device must be checked for compatibility with the respective application requirements (contacting materials, process temperature) before use. An unsuitable material can lead to damage, abnormal behavior or destruction of the device and to the resulting dangers.

The sensors may not be used as sole device for prevention of dangerous conditions in machines and plants.

Using the device in a manner that does not fall within the scope of its intended use, disregarding this instruction, using under-qualified personnel, or making unauthorized alterations releases the manufacturer from liability for any resulting damage. This renders the manufacturer's warranty null and void.



Safety notes for electrical operating supplies for explosive hazardous areas

If a device is installed and operated in explosive hazardous areas, the general Ex construction standards (EN/IEC 60079-14, VDE 0165), these safety notes and the enclosed EC conformity certificate must be observed.

The installation of explosive hazardous systems must be carried out principally by specialist staff.

The device meets the classification

II 1 G Ex ia IIB/IIC T6...T1 Ga resp.

II 1/2 G Ex ia IIB/IIC T6...T1 Ga/Gb resp.

II 2 G Ex ib IIB/IIC T6...T1 Gb

The devices are conceived for detection of limit values in explosive hazardous areas. The measured medium may also be combustible liquids.

The permitted operating temperatures and pressures are type and variant dependent and can be found in this technical manual.

For applications, which require devices of category 1 or category 1/2, the process pressure and temperature range of the media has to be between 0,8 bar and 1,1 bar and between -20 °C and 60 °C.

If a device is mounted in the separation wall to the hazardous area that requires devices of category 1, the process connections have to be designed in such a way, that they are sufficiently tight according to EN/IEC 60079-14 section 4.6.

The operating device may only remain in the zone when connected to an evaluation device and connected to the potential compensation.

The metallic process connection resp. the metallic connection housing must be connected with the potential compensation of the explosion hazardous area.

The device is earthen for safe technical function. Provide sufficient potential compensation along the complete cable way. Install the intrinsically safe circuit earth free.

At variants of the devices with chargeable plastic parts (e.g. connection housing, isolation), a warning marking points out to the safety measures, that must be applied because of the electrostatic charging in operation and especially in the case of maintenance activities.

- avoid friction
- no dry cleaning
- no assembling in pneumatic conveying stream
- protect the electrode rods against pendular movements

Installation

The isolation of the electrode rod may not be damaged resp. removed excepted at the electrode tip.

The electrode rods can be cut arbitrarily by a tong or a saw. After cutting the electrode rod, remove 10 mm of the isolation. The electrode may not be mechanically forced at the cutting, to avoid damaging the isolation.

Installation notes

Drive the system pressure free prior installation resp. deinstallation of the device and avoid high temperatures to avoid injuries.

Consider enough installation space outside the container, to insert the electrode probe into the plant without the use of force.

Install the device if necessary into a bypass if dense heavy foam, wild turbulences or foamed liquids can occur.

If a metallic wall of a container resp. pipeline should be used as reference electrode there must be paid attention that the metallic process connection of the electrode probe is safe electrically conductive connected with the container resp. the pipeline. Use conductive gaskets like e.g. copper or lead. Isolation measures like e.g. the wrap of the thread with teflon band or a paper gasket can interrupt the electric contact.

Install the electrode probe in such a position in the container, where no strong forces to the side, like e.g. by mixer or near fill-in openings, can have an effect to the electrode rods.

This is especially important for especially long electrode rods.

The non-isolated electrode tips, when mounted, may not make a contact to the wall of the container, if this is made of metal or electrically conductive plastic.

Electrode rods longer than 0,5 m must be stabilized among each other or against the wall of the container, especially if the filling material is strongly fluctuating.

Use for the stabilization suitable isolating spacers.

The distance between the spaces should be not more than 0,5 m.

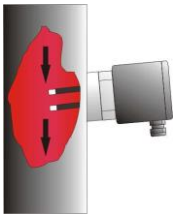

At horizontal side mounting into a container or also into a pipe for stability reasons the length of the electrode rods should be not more than 200 mm.

At wider electrode rods (8 mm) the length can be longer.

At a horizontal mounting the electrode rods should be installed at an angle with the electrode rod tip below (approx. 20°), to allow an easier flow-off of filling material residues and by this to avoid the coat-forming.



At horizontal pipelines the length of the electrodes is limited by that way, that in a empty pipe, also in the case of liquid residues, the electrically conductive liquid connection between electrode and wall resp. between the two electrode rods can disconnect. Otherwise and empty pipe can be detected as filled.

At process connections with a screwing thread the tightening of the process connection may only be done at the hexagon by a suitable spanner. The maximum permitted torque strength is 100 Nm.

The screw in of the process connection by using the connection housing is not permitted.

Maintenance

The device is free of maintenance.

The isolation of the electrodes should be checked regularly and also a possible coating at the electrode tips should be removed.

A non-conductive coating at the metallic electrode tip can effect error behaviour because no current can flow although the electrically conductive filling material makes a connection.

Repair

A repair may only be carried out by the manufacturer.

If the device must be sent back for repair, the following informations must be enclosed:

- An exact description of the application.
- The chemical and physical characteristics of the product.
- A short description of the occurred error.

Before returning the device for repair, the following measures must be proceeded:

- All stick product residues must be removed. This is especially important, if the product is unhealthy, e.g. caustic, toxic, carcinogenic, radioactive etc.
- A returning must be refrained, if it is not possible by 100% to remove the unhealthy product completely, because e.g. it is penetrate into cracks or is diffused through plastic.

Electrical connection

The electrical connection of the device must be carried out according to the respective country specific standards. Incorrect installation or adjustment could cause applicationally conditioned risks.

Use only suitable cables with max. 25 Ω per wire, that fulfills the requirements e.g. regarding temperature, resistance or laying at the place of installation.

The cable gland is suitable for cable diameters from 3,5 to 8 mm. After installation of the cable the cable gland must be fix screwed to ensure the tightness of the connection housing.

Use only shielded signal and measurement wires and install these wires separated from power leading wires. At strong electromagnetic irradiation use principally a cable with shield. Connect the cable shield only at one side to earth.

A suitable evaluation device must be connected by the connection cable with the electrode rods inside the connection housing.

The connection of the cable to the electrode rods resp. ropes is made by terminals for wire cross-cuts up to 2,5 mm² or by screw connections inside the connection housing. For the connection use isolated thimbles. The metallic process connection can be contacted by a tab.

At electrode probes an additional module (diode module LBM) for the wire supervision can be installed inside the housing. This must always be connected between the shortest rod and the longest rod resp. at electrode probe with metallic process connection between this and the shortest rod.

A connection polarity is not relevant. When using evaluation devices resp. transmitter, that does not support a wire supervision, this module may not be installed.

For inauguration it is suggested to switch off all connected control devices to avoid unintended control actions.

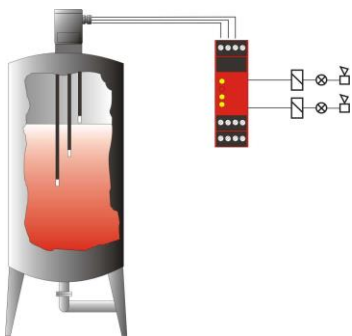

Two-position-control

For a two-position-control, an electrode probe with three rods must be used, where the longest rod represents the reference electrode.

Alternatively at a container with electrically conductive wall an electrode probe with only two rods can be used.

Here the container wall represents the reference electrode.

The evaluation device with a function for two-position-control keeps the filling material level between the upper and the lower limit level.

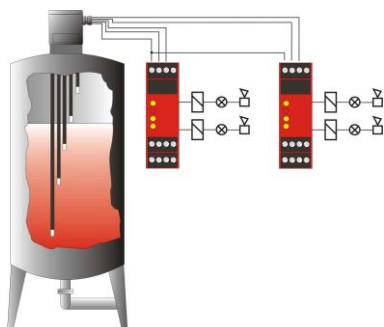

Four-level-detection

For a four-level-detection an electrode probe with five rods must be used, where the longest rod represents the reference electrode.

Alternatively at a container with electrically conductive wall an electrode probe with only four rods can be used.

Here the container wall represents the reference electrode.

For the evaluation two two-channel-evaluation-devices are used, whose both reference connection must be connected with the longest electrode or with the metallic process connection.

Technical data

Materials

Electrode rod: Steel 1.4404 (AISI316L) resp. 1.4571 (AISI316Ti) / Hastelloy B4, C22 / Titan
 (medium contact)
 Electrode rod isolation: ETFE
 (medium contact)
 Process connection: Steel 1.4404 (AISI316L) resp. 1.4571 (AISI316Ti)
 (medium contact)
 Terminal enclosure: CrNi-steel / POM / PP / PTFE
 Cable gland:

Terminal enclosure CrNi-steel	Enclosure CrNi-steel / Gasket CR, NBR
Terminal enclosure POM / PP / PTFE	Enclosure PA / Gasket CR, NBR

Gaskets: Medium contact: EPDM, FDA-listed
 Others: NBR, FPM

Environmental conditions

Environmental temperature: Maximum – 20°C...+100°C, observe limitations

Limitation by variant	Environmental temperature range
ATEX zone 0	-20...+60°C
ATEX T6	-20...+80°C
ATEX T5...T1	-20...+95°C

Limitation by material	Environmental temperature range
Connection housing PP	+5...+100°C

Process temperature: Maximum – 40°C...+130°C, observe limitations

Limitation by variant	Process temperature range
ATEX zone 0	-20...+60°C
ATEX T6	-40...+80°C
ATEX T5	-40...+ 95°C
ATEX T4	-40...+ 130°C
ATEX T3...T1	-40...+ 130°C

Process pressure: Standard -1 bar...+20 bar
 ATEX zone 0 +0,8 bar... +1,1 bar

Conductivity: ≤ 1 MΩ resp. ≥ 1 μS/cm, depends on connected evaluation device

Protection classification: IP65 EN/IEC 60529

Weight: Depends on:
 - material / size of terminal enclosure resp.
 - material / style of process connection resp.
 - material / diameter / number / length of the electrodes

Dimension drawings

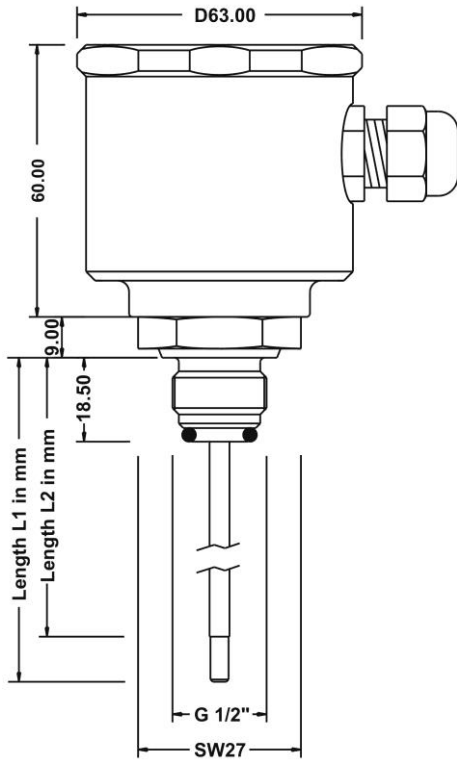

process connection
G12 – G 1/2"

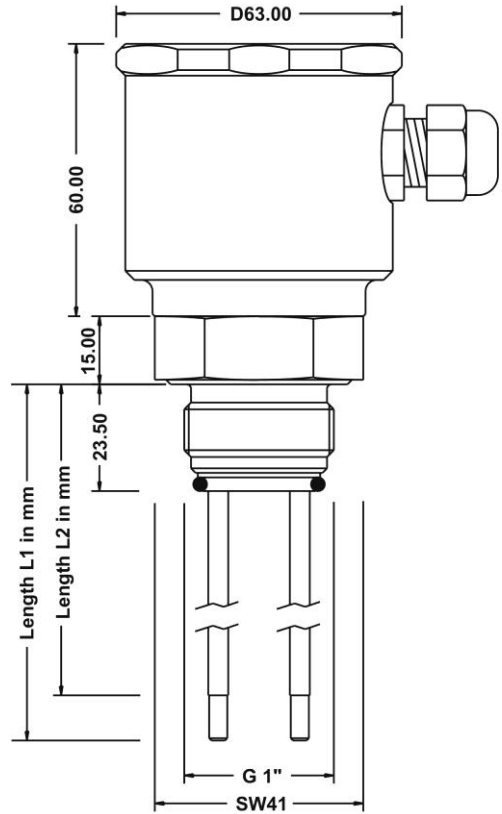

process connection
G10 – G 1"

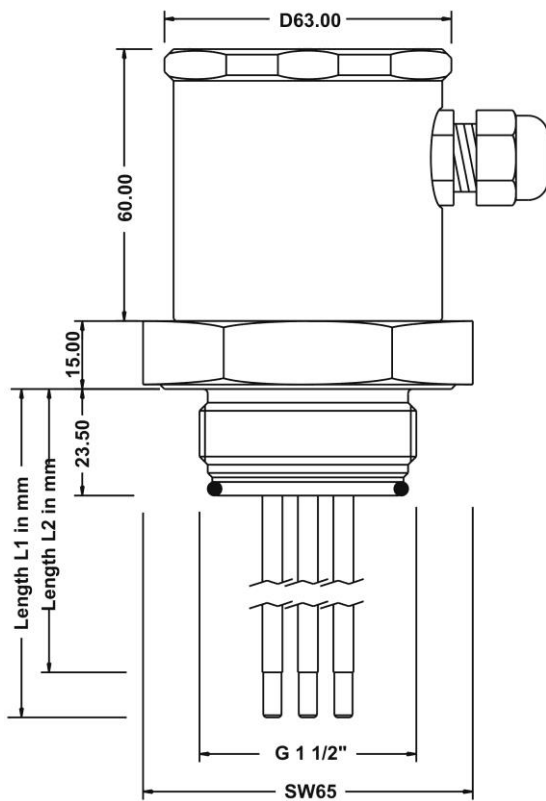

process connection
G15 – G 1 1/2"

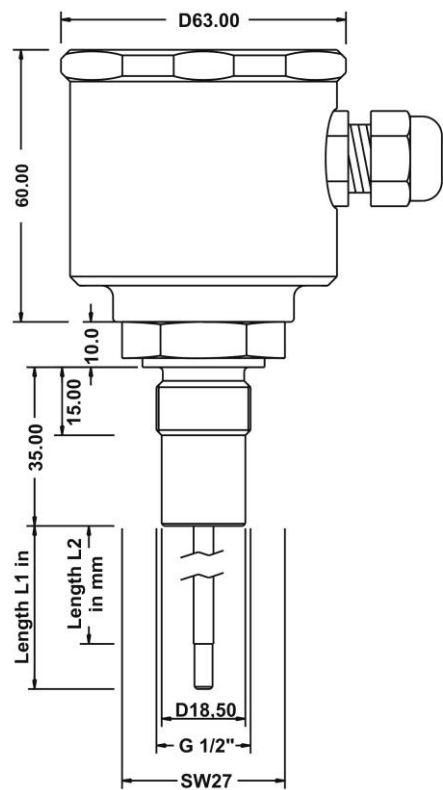

process connection
M12 – G 1/2"
metallic sealing

Dimension drawings

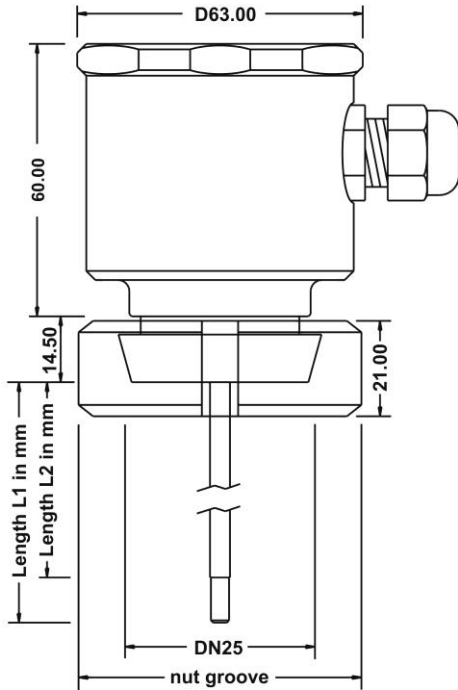

process connection
D25 – DN25

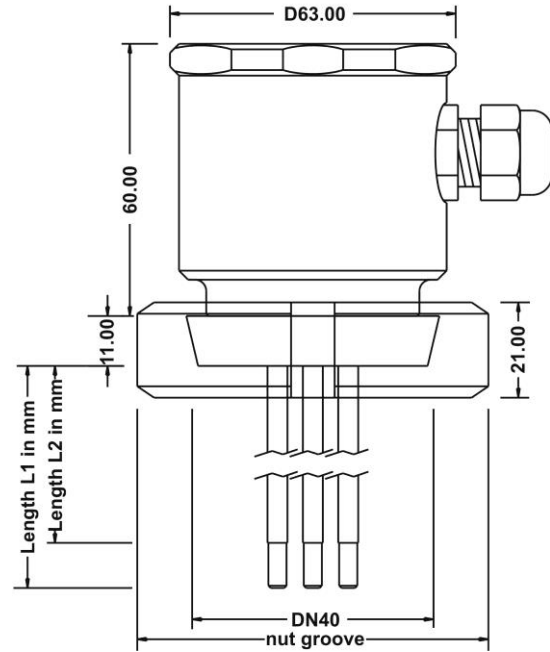

process connection
D40 – DN40

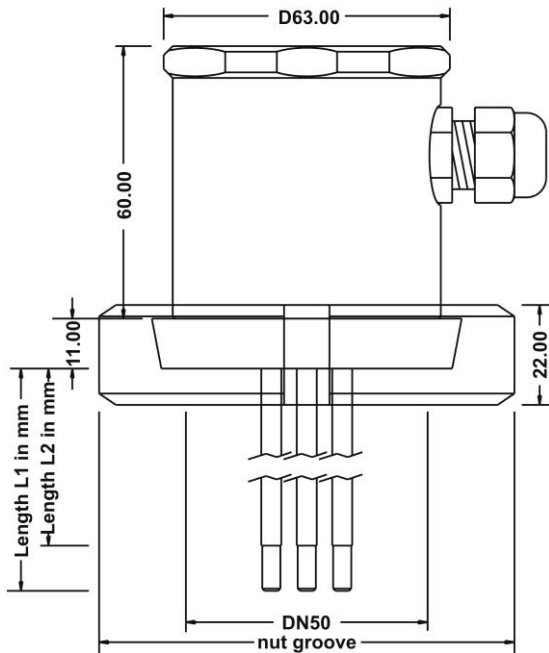

process connection
D50 – DN50

Order code overview

Type

- 0 Standard
- Ex ATEX II 1 G Ex ia IIB/IIC T6...T1 Ga

Electrode number

- 1 1 electrode rod
- 2 2 electrode rods
- 3 3 electrode rods
- 4 4 electrode rods

Process connection (material CrNi-steel medium contact)

- D25 Dairy coupling DIN 11851 – DN25, 1-rod
- D40 Dairy coupling DIN 11851 – DN40, 1-/2-/3-rod
- D50 Dairy coupling DIN 11851 – DN50, 1-/2-/3-/4-rod
- G12 Thread ISO 228-1 – G ½“, O-ring front flush, 1-rod
- G10 Thread ISO 228-1 – G 1“, O-ring front flush, 1-/2-/3-rod
- G15 Thread ISO 228-1 – G 1 ½“, O-ring front flush, 1-/2-/3-/4-rod
- M12 Thread ISO 228-1 – G ½“, metallic sealing, 1-rod

Material electrode rod (medium contact)

- A4 CrNi-steel, rod diameter 4 mm
- A8 CrNi-steel, rod diameter 8 mm
- C Hastelloy B4, rod diameter 4 mm
- D Hastelloy C 22, rod diameter 4 mm
- T4 Titan, rod diameter 4 mm
- T8 Titan, rod diameter 8 mm
- E CrNi-steel, tip tantalum 50mm, on request
- Y others on request

Material connection housing

- D POM
- V CrNi-steel
- M PP
- L PTFE
- Y others on request

Material electrode isolation (medium contact):

- H4 ETFE, rod diameter 4 mm
- H8 ETFE, rod diameter 8 mm

Wire break monitoring:

- A without
- B Diode module LBM

Diameter electrode rod:

- 0 4 mm (L1 max. 2000mm)
- W 8 mm (L1 max. 3000mm)

Length L1 electrode rod in mm

Length L2 electrode isolation in mm

SLK _ _ _ _ _ _ _ _ _ _