

Technical manual BA 0419



Temperatur



Thermocont ST Temperature transmitter

for measuring and surveillance of process temperatures
in gases, vapors, liquids and dusts

- Recording of process temperatures in the range from – 100 °C to +500 °C
- Various selection of process connections
- Process pressures from -1...60 bar
- Various usability, especially for hygienic applications
- Long-term stable temperature sensor in platinum Pt100 acc. to EN/IEC 60751
- ATEX II 1/2 G Ex ia IIC T4 Ga/Gb resp.
- ATEX II 1/2 D Ex ia IIIC T85°C/T102°C Da/Db
- Certification for the use in explosion hazardous areas
- Programmable evaluation electronic with high brightness LED-display
 - in 2-wire-technology with current signal 4...20 mA or
 - in 3-wire-technology with voltage signal 0...10 V
 - with two PNP switching outputs

ACS-CONTROL-SYSTEM
know how mit system



Lauterbachstr. 57 – 84307 Eggenfelden – Germany
Tel: +49 8721/9668-0 – Fax: +49 8721/9668-30
info@acs-controlsystem.de – www.acs-controlsystem.de

Index

Application description	3
Function	3
Safety notes	4
Safety notes 	4
Installation	5 / 6 / 7
Maintenance	7
Repair	7
Electrical connection	8 / 9 / 10
Operation and display elements / function modes	11
Function description	12
▪ Analogue output / PNP – switching output / damping / function scheme	12 / 13
▪ Adjustment menu	14
▪ Extension menu	15
Technical data	16 / 17 / 18
Dimension drawings	19 / 20
Order code overview	21

Application description

The devices of the series **Thermocont ST** with integrated digital evaluation electronic are compact temperature transmitter for continuous measuring and surveillance of temperatures from -100 up to $+500^{\circ}\text{C}$ in gases, vapors, liquids and dusts, also in explosive hazardous areas, at process pressures from -1 to $+60$ bar.

The use of a long-term stable resistance temperature sensor Pt100, by using various process connections, allows the use in nearly all fields of industry, especially also in hygienic applications

Function

The device **Thermocont ST** is used for temperature measurement by recording the ohmic resistance of a resistance temperature sensor Pt100.

The sensor tube of the temperature transmitter is the junction point with the applied medium and is in direct contact with it. Inside, the resistance temperature sensor Pt100 is installed, that is used for the recording of the temperature and for its conversion into an electrical signal.

The resistance temperature sensor element Pt100, dependent on the requirements for accuracy up to class A, ensures a precise and long-term stable temperature measurement.

By using a neck tube of a corresponding length between the respective process connection and the connection housing at high medium temperatures, it can be achieved, that the temperature in the area of the connection housing does not exceed the permitted environmental temperatures.

Signal processing

The temperature dependent variation of resistance is recorded in high resolution by a processor, adjusted acc. to the settings and converted in high resolution into an output signal of $4\dots 20\text{mA}$ or $0\dots 10\text{V}$.

According to the resp. settings the PNP switching outputs are driven at the variant with output signal $4\dots 20\text{mA}$ resp. $0\dots 10\text{V}$.

The switching state of the two PNP switching output are indicated by each an LED.

By 3 keys and the four digit LED display all settings for the display, the analogue output as well as the PNP switching outputs can be set resp. adjusted.

A transmitter fast adjustment per key combinations is also possible.

A offset correction in the range from $-25,0\text{ K}$ to $+25,0\text{ K}$ is possible, e.g. for the compensation of losses in the measuring signal through the container wall resp. because of the installation situation.

Safety notes



Each person that is engaged with inauguration and operation of this device, must have read and understood this technical manual and especially the safety notes.

Installation, electrical connection, inauguration and operation of the device must be made by a qualified employee according to the informations in this technical manual and the relevant standards and rules.

The device may only be used within the permitted operation limits that are listed in this technical manual. Every use besides these limits as agreed can lead to serious dangers.

The materials of the device must be chosen resp. checked for suitability to the respective application requirements (contacting substances, process temperature). An unsuitable material can lead to damage, abnormal behavior or destruction of the device and to the resulting dangers.

The device may not used as sole device for prevention of dangerous conditions in machines and plants.

This device meets article 3 (3) of the EC directive 97/23/EC (pressure equipment device directive) and is designed and produced in good engineer practice.

The device meets the legal requirements of all relevant EC directives.  0158



Safety notes for electrical operating supplies for explosive hazardous areas

If a device is installed and operated in explosive hazardous areas, the general Ex construction standards (EN/IEC 60079-14, VDE 0165), this safety notes and the enclosed EC conformity certificate incl. supplements must be observed.

The installation of explosive hazardous systems must be carried out principally by specialist staff.

The device meets the classification

	T_a Medium	T_a Housing
II 1/2 G Ex ia IIC T4	-20... +60 °C	-20...+85 °C
II 1/2 D Ex iaD 20/21 T85°C / T102°C (T57°C)	-20... +60 °C	-20...+85 °C (+40 °C)
II 2 G Ex ib IIC T4/T3/T2/T1	-100...+110 / +170 / +265 / +415 °C	-20...+85 °C
II 2 D Ex ibD 21 T135 / 195 / T290 / 440°C	-100...+110 / +170 / +265 / +415 °C	-20...+85 °C

The highest surface temperature is determined inside the housing at complete fill up, that means thermal isolation. The power at the sensor is negligible.

The devices are conceived for measuring of temperatures in explosive hazardous areas.

The measured medium may also be combustible gases, vapors, liquids and dusts.

The permitted operating temperatures and pressures are type and variant dependent and can be found in this technical manual.

For applications, which require devices of category 1/2 or category 1, the process pressure and temperature range of the medium has to be between 0,8 bar and 1,1 bar and between -20 °C and 60 °C.

The permissible maximum values for U_i , I_i and P_i are equal for variants A/B/E/F. To this there must be paid especially attention in the case of combining more intrinsically safe circuits at the variants with voltage output 0...10V (variants E/F) and at the variants with PNP switching outputs (variants A/E). The rules for combination of intrinsically safe circuits must be applied.

The PA terminal inside the connection housing resp. the process connection must be connected to the potential compensation of the explosive hazardous area.

At variants of the devices with chargeable plastic parts (e.g. cable resp. connection housing), a warning marking points out to the safety measures, that must be applied because of the electrostatic charging in operation and especially in the case of maintenance activities.

avoid friction - no dry cleaning - no assembling in pneumatic conveying stream

Installation

Forces to the side of the sensor tube, produced e.g. by mixer or near fill-in openings should be avoided.

The installation position has influence on the measuring result of the kind of a zero value shift because of the temperature losses due to the container wall or due to heat irradiation resp. transfer. This deviation can be eliminated by an offset adjustment.

Drive the system pressure free prior installation resp. deinstallation of the device.

Be also sure that no medium is flowing in the system.

At extreme system or medium temperatures there could exist serious dangers.

The tightening of the process connection with screw-in thread may only be done at the hexagon by a suitable spanner.

The maximum permitted torque strength is 50 Nm.

The screw in of the process connection by using the connection housing is not permitted.

The housing can be rotated every time, also at operation, by 330°.

The correct function of the device within the specific technical data can only be guaranteed, if the permitted temperature in the area of the connection housing (see technical data) will not be exceeded.

This can be achieved by the using a neck tube or also by isolation of the medium carrying part of the plant or by other constructive measures to reduce the transferring of an extreme temperature to the connection housing.

Maximum permitted process temperature dependent of the environmental temperature

environmental temperature in the area of the connection housing	maximum permitted process temperature without using a neck tube
up to +25°C	+150°C
up to +40°C	+135°C
up to +60°C	+120°C
up to +85°C	+100°C

Neck tube

The neck tube is used to decouple the temperatures between medium and connection housing in order to reduce the temperature at the connection housing.

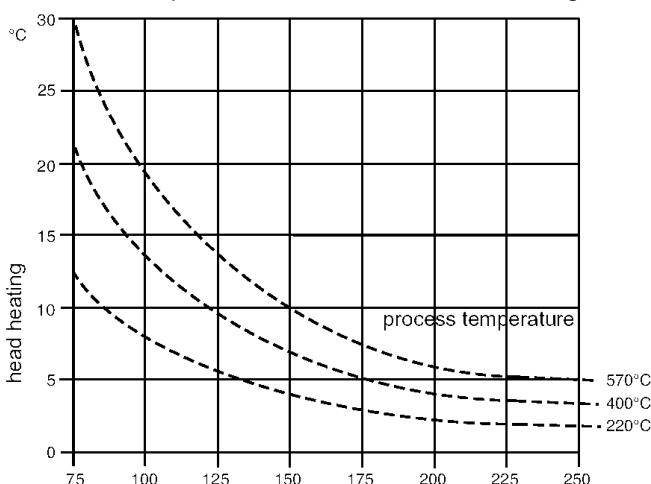

By using a neck tube at extreme process temperatures it can be achieved that the permitted environmental temperature range from -40°C...+85°C in the area of the connection housing will not be exceeded.

The length of the needed neck tube depends on the height of the process temperature and the respective installation situation.

Like shown in the graphic besides, the length of the neck tube can considerably influence the temperature at the connection housing.

The graphic is only a approximately guide, because the real heating of the connection housing can be influenced by additional factors, e.g. a system isolation or also the position of the connection housing.

Installation

Installation position

The choosing of the place of installation of the sensor and the length of the sensor tube are of considerably importance for the quality and the reliability of the measurement results.

The signal recording sensor element is mounted in the tip of the sensor tube.

If the sensor isn't installed deeply enough, an error in the measured temperature can occur because of the different process flow temperature at the pipe wall and the heat transfer along the sensor tube.

The appearance of the error should not be ignored if a considerable difference between process temperature and environmental temperature exists. To avoid measurement errors of this kind, a installation length of at least 80...100 mm is suggested.

The shorter the installation depth is chosen, the greater is the deviation against the real medium temperature caused by the heat transfer.

The following general suggestions can be applied as approximately guideline:

- In liquids, the installation length should be 5...6 times greater then the diameter of the sensor tube plus the sensitive length of 50 mm.
- In vapor, air and gases, the installation length should be 10...15 times greater then the diameter of the sensor tube plus the sensitive length of 50 mm.

In pipes with small diameter the tip of the sensor tube should reach the axis line, that means the middle of the pipe, and if possible additionally a little more. By isolating the external parts of the sensor, the effect caused by too low installation depth, can be reduced. An additional solution for optimizing the measurement quality of small formatted tubes could be the installation of the sensor tube diagonal to the pipe longitudinal axis or the installation of the sensor tube in the pipe arc (see illustration).

If the deviation between the real process temperature and the temperature, that is recorded by the temperature transmitter Thermocont ST can be determined, an offset adjustment for the compensation of the deviation is possible.

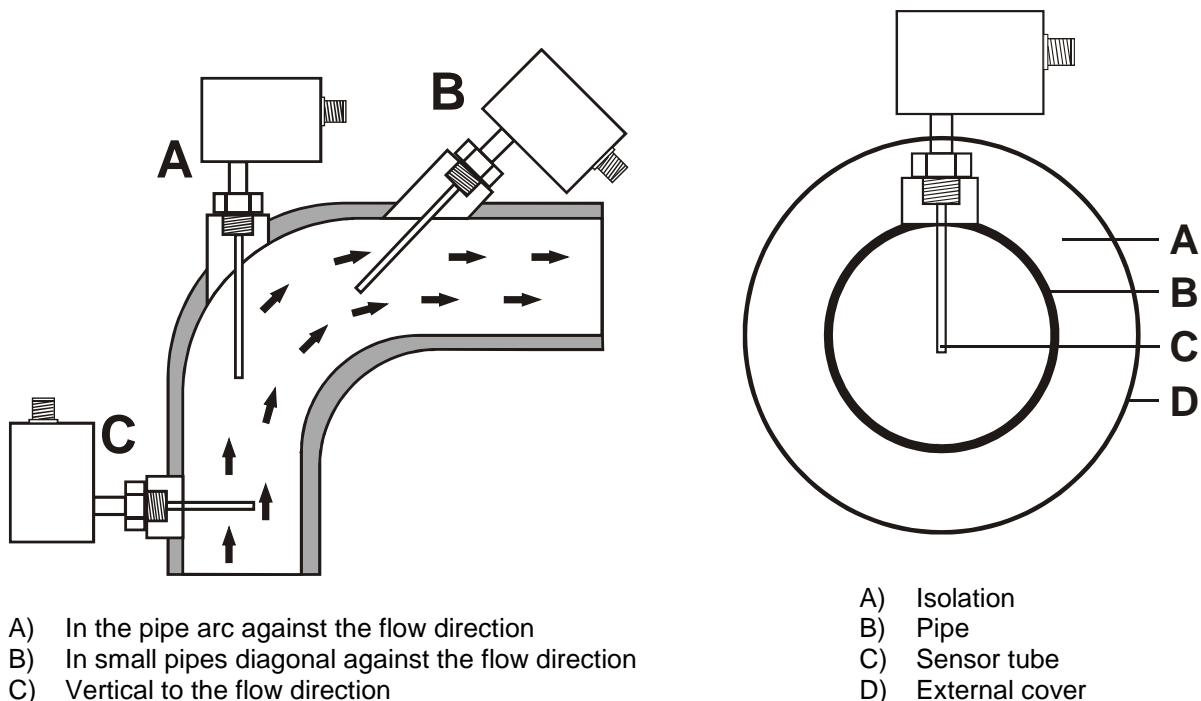

At a horizontal installation the device should be installed at an angle with the sensor tube tip below (approx. 20...30°), to allow an easier flow-off of filling material residues.

Installation

Installation position

It the temperature sensor is applied to a temperature variation, a defined time goes by until the sensor has take over this new temperature. This time depends on the style of the thermometer and the environmental conditions (like e.g. flow speed, medium, etc.).

The following specifications refers to measurement in Water with 0,4 m/s, temperature step 23 to 33°C acc. to EN/IEC 60751.

The response times for other medias can be determined by using the thermal exchange constant acc. to VDI/VDE 3522.

Sensor tube diameter 6 mm	→ response time $t_{50} = 11$ s	→ response time $t_{90} = 37$ s
Sensor tube diameter 8 mm	→ response time $t_{50} = 15$ s	→ response time $t_{90} = 49$ s
Sensor tube diameter 10 mm	→ response time $t_{50} = 18$ s	→ response time $t_{90} = 55$ s
Reduced tip diameter 3 mm	→ response time $t_{50} = 6$ s	→ response time $t_{90} = 18$ s
Reduced tip diameter 5 mm	→ response time $t_{50} = 7,5$ s	→ response time $t_{90} = 21$ s
Reduced tip diameter 6 mm	→ response time $t_{50} = 11$ s	→ response time $t_{90} = 37$ s

Maintenance

The devices is free of maintenance.

Repair

A repair may only be carried out by the manufacturer.

If the device must be sent back for repair, the following informations must be enclosed:

- An exact description of the application.
- The chemical and physical characteristics of the product.
- A short description of the occurred error.

Before returning the device for repair, the following measures must be proceeded:

- All stick product residues must be removed. This is especially important, if the product is unhealthy, e.g. caustic, toxic, carcinogenic, radioactive etc.
- A returning must be refrained, if it is not possible by 100% to remove the unhealthy product completely, because e.g. it is penetrate into cracks or is diffused through plastic.

Electrical connection

The electrical connection of the device must be carried out according to the respective country specific standards. Incorrect installation or adjustment could cause applicationally conditioned risks.

Use only twisted shielded signal and measurement wires and install these wires separated from power leading wires. Connect the cable shield only at one side to earth, ideally at the installation place of the device. The metallic parts of the device with connection housing plug - type S resp. cable - type K are electrically connected with the earthing connection screw. At the variant with connection housing terminal box – type A all metallic parts are connected with terminal 1 - PE/shield. The device must be grounded, e.g. by the earth terminal screw or by the process connection.

At the housing variant with terminal box, the terminals for wire cross-section from 0,5...2,5mm², for the connection of a cable are placed below the electronic module. This is plugged and can be pushed easily. After the connection of the cable, the module must be correctly inserted again.

The cable gland is suitable für cable diameter from 4,5 to 10 mm.

After the installation of the cable the cable gland must be firmly screwed to ensure the tightness of the connection housing. The same is valid for the screw cap of the housing.

The voltage applied to the terminal contacts may not exceed 45 V to avoid damage of the electronic. All connections are polarity protected.

The minimum resp. maximum supply voltage depends on the respective variant:

Variant	not Ex	Ex
Thermocont ST	14,5...45V DC	14,5...30V DC

A load, e.g. the measuring shunt of an evaluation device, in series with a sensor of the variant A/B with 4...20 mA current signal in 2-wire-technology reduces the supply voltage available at the sensor. Dependent on version resp. minimum supply voltage, it results in a maximum value for this resistor, where a correct function is still possible.

The maximum load at signal current 20mA can be calculated by the equation:

$$R_L \text{ max} = (V_{S \text{ act.}} - 14,5V) / 20\text{mA}$$

with $V_{S \text{ act.}}$ = applying supply voltage and $V_{S \text{ min}}$ = minimum supply voltage.

The following graph shows the characteristics for the resistor values at 24 V and 45 V.

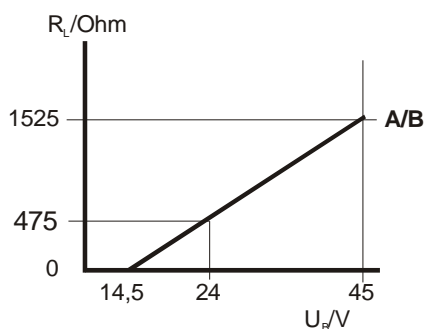

Inductive loads at the pnp switching outputs, e.g. relays or contactors may only be used with a free-wheeling diode or a RC protection circuit to avoid high voltage peaks.

The load at the PNP switching output will be connected to the terminal +terminal of the supply voltage by a semiconductor switch contactless and by this bounce-free. At an activated switching state a positive signal near supply voltage is feed to the output.

At deactivated switching state and at failure of supply voltage the semiconductor switch is shut off.

The PNP switching output is current limited to 0,2...0,25 A and is overload and short circuit protected.

Assignment

connection type S plug M12x1

connection type K cable

connection type A terminal box

2 – wire – technology / signal 4...20 mA

variant B

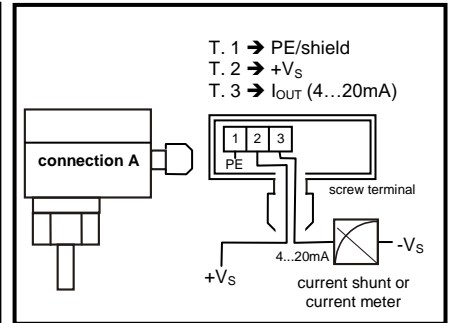
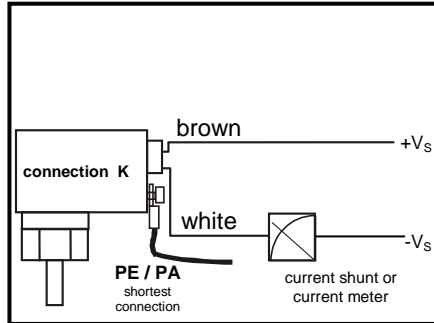
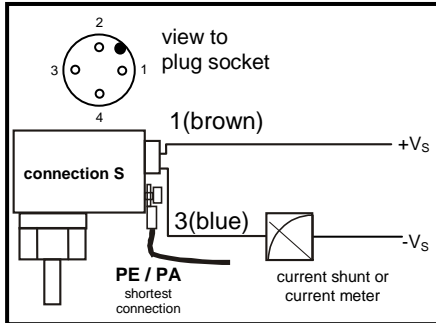

2 – wire – technology / signal 4...20 mA / 2x PNP switching output

variant A

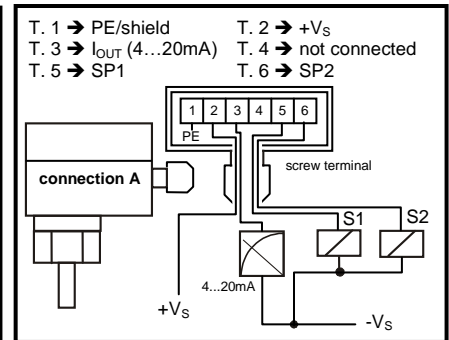
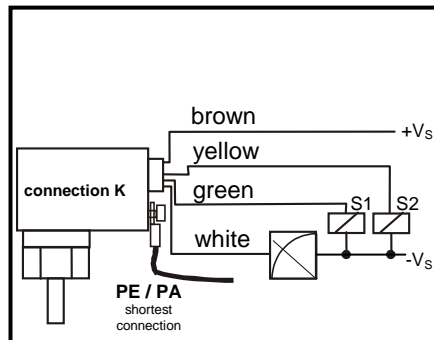
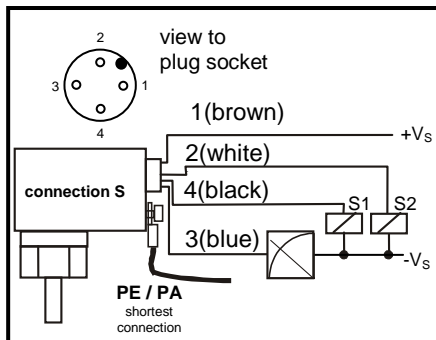

3 – wire – technology / signal 0...10 V

variant F

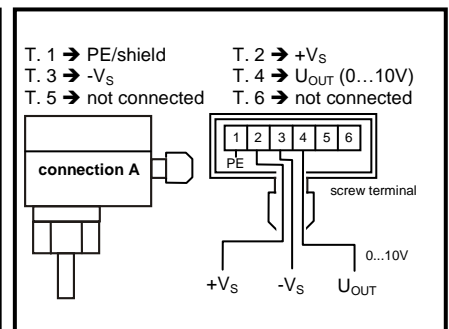
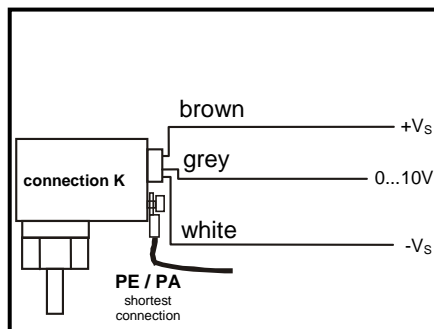
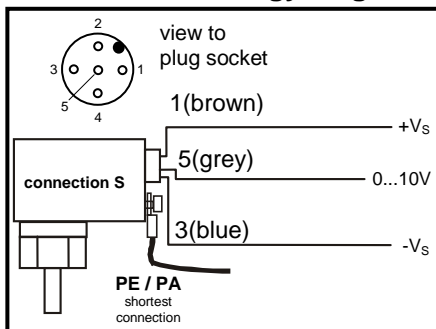

3 – wire – technology / signal 0...10 V / 2x PNP switching output

variant E

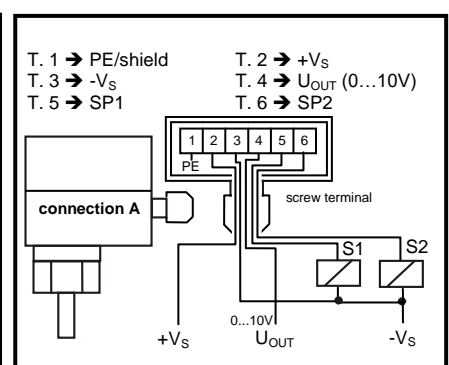
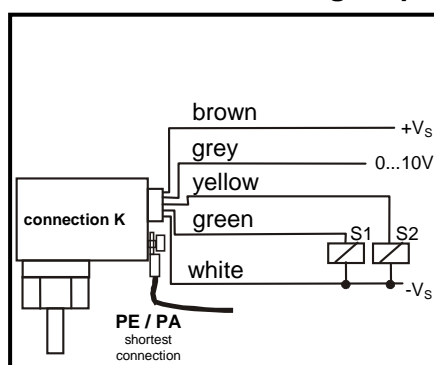
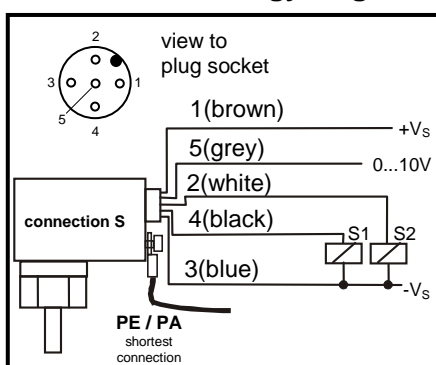

Electrical connection in an explosion hazardous area

2 – wire – technology / signal 4...20 mA

transmitter electronic B

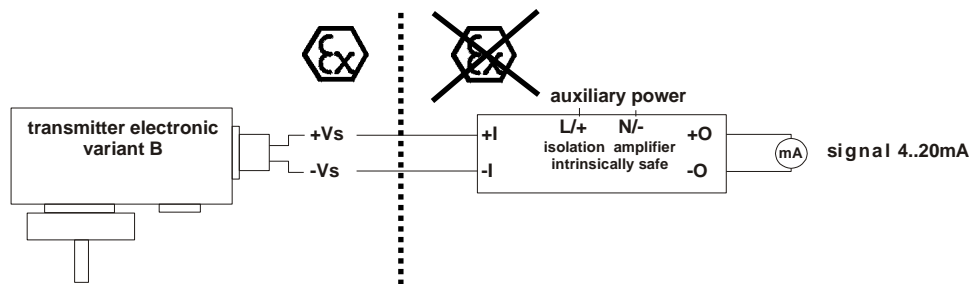

2 – wire – technology / signal 4...20 mA / 2x PNP switching output

transmitter electronic A

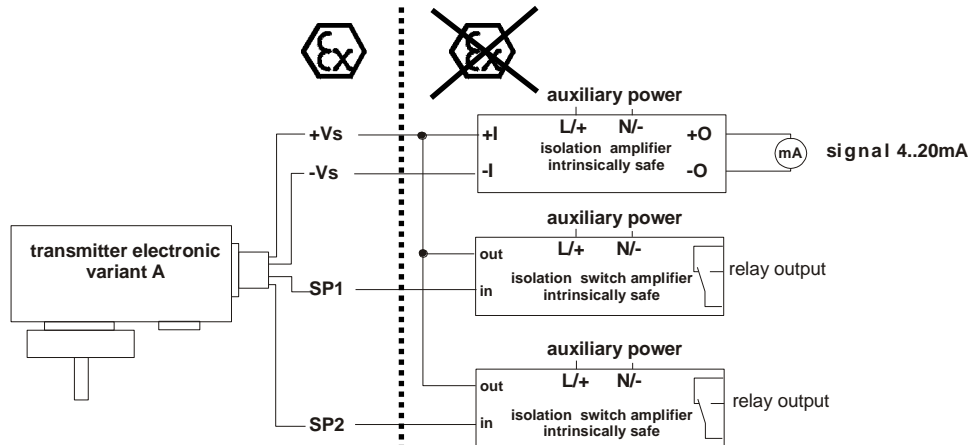

3 – wire – technology / signal 0...10 V

transmitter electronic F

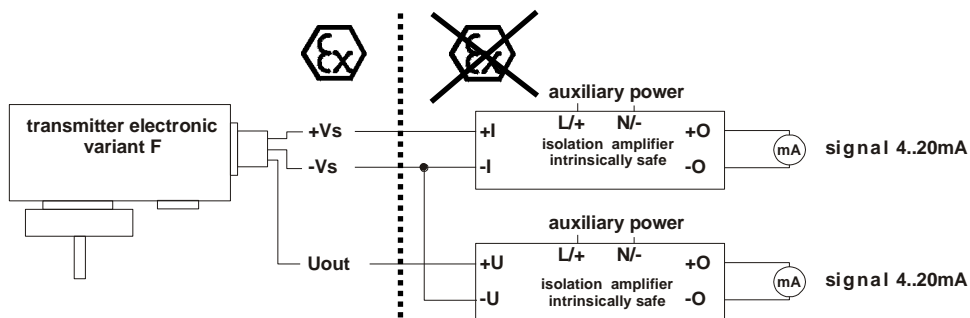

3 – wire – technology / signal 0...10 V / 2x PNP switching output

transmitter electronic E

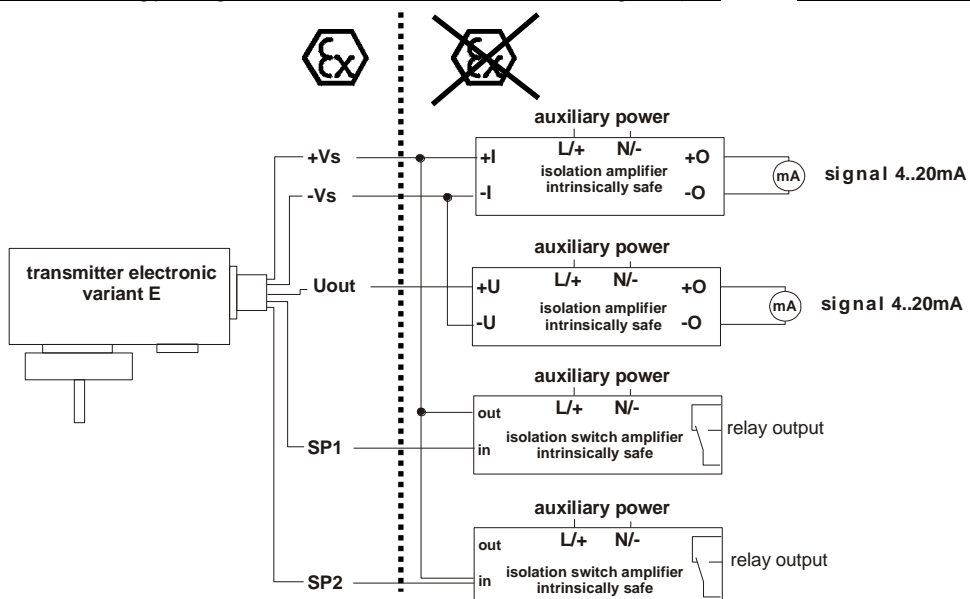

Operation and display elements

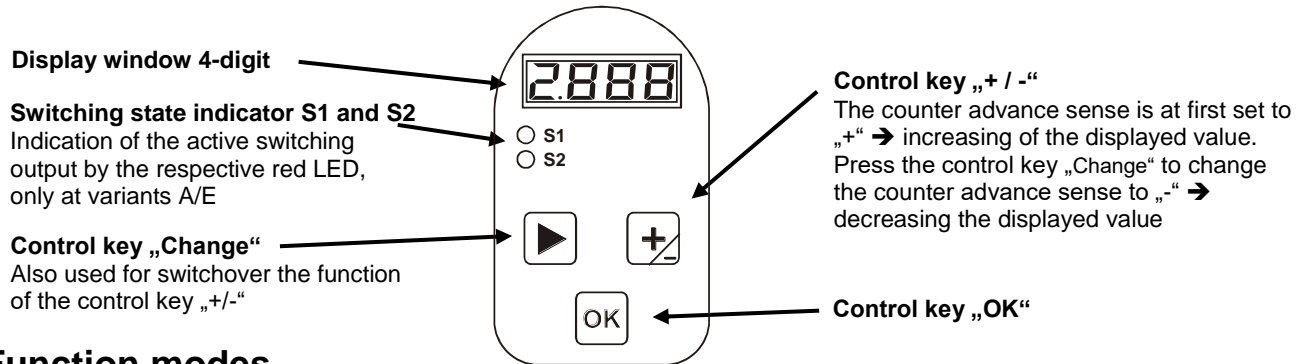

Function modes

run mode

The temperature transmitter records the process temperature and proceeds the chosen functions according to the set parameter. The measuring value is displayed in the display window.

The analogue output and the switching outputs are driven. A switched-on switching output is signaled by the come on of the respective red switching condition light-emitting diode.

The exceeding of the frame specifications, abnormal behavior conditions or also device malfunctions are displayed by the display values E E E E resp. - E E E .

By pushing the control key „+ / -“ the software version will be displayed

Programming mode

To access to the adjustment menu push the control key „OK“ and enter the **password 3009**.

Fast adjustment mode

By pushing of key combinations in the run mode the transmitter can be operated without using the adjustment menu.

Zero value adjustment with applied temperature signal:

Short pushing the key's „Change“ and „OK“ in succession and hold approx. 6 seconds.

The output signal 4mA / 0V is generated that can be varied by „+ / -“ resp. „Change“ and „+ / -“.

By pushing the key „OK“, the current temperature value is captured as lower temperature reference value, assigned to the previously adjusted output signal and the changed settings are stored loss protected.

A jump back to the run mode is carried out.

End value adjustment with applied temperature signal:

Short pushing the key's „+ / -“ and „OK“ in succession and hold approx. 6 seconds.

The output signal 20mA / 10V is generated that can be varied by „+ / -“ resp. „Change“ and „+ / -“.

By pushing the key „OK“, the current temperature value is captured as upper temperature reference value, assigned to the previously adjusted output signal and the changed settings are stored loss protected.

A jump back to the run mode is carried out.

Offset correction:

Short pushing the key's „Change“ and „+ / -“ in succession and hold approx. 6 seconds.

The offset correction value can now be varied. This value can be varied arbitrary by „+ / -“ resp.

„Change“ and „+ / -“ from -25,0 K to +25,0 K. By pushing the key „OK“, the value is captured and stored loss protected. A jump back to the run mode is carried out.

Attention:

If the lower temperature reference value (zero) is adjusted higher than the upper temperature reference value (span), the output signal falls **below** 3,8mA resp. to 0V. The display shows **EEEE** as long as the key „OK“ is pushed. A readjustment has to be done correctly (zero < span).

Function description

Analogue output

The temperature signal is transmitted to the analogue output, in which the adjusted temperature zero value equals an output current of 4 mA resp. an output voltage of 0 V and the adjusted temperature end value equals an output current of 20 mA resp. an output voltage of 10 V.

At an adjustment by *Zero resp. Span*, the temperature zero value resp. the temperature end value and thus the zero value (4 mA / 0 V) resp. the end value (20 mA / 10 V) of the analogue output can be shifted.

The output signal behaves depending on the set mode in three different possibilities:

- ① Linear signal transmission in the range from 3,9 mA to 21 mA resp. 0 V to 10,5 V. The limit values are kept at exceeding or underrun.
- ② Linear signal transmission in the range from 4 mA to 20 mA resp. 0 V to 10 V. At exceeding or underrun of these limit values a jump to 3,8 mA resp. 0 V is proceeded for an error evaluation.
- ③ Linear signal transmission in the range from 4 mA to 20 mA resp. 0 V to 10 V. At exceeding or underrun of these limit values a jump to 22 mA resp. 11 V is proceeded for an error evaluation.

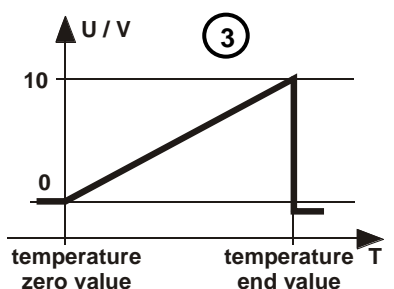
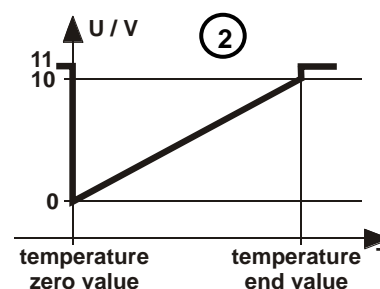
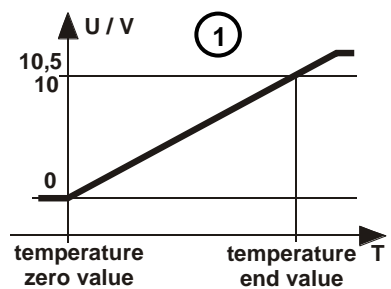
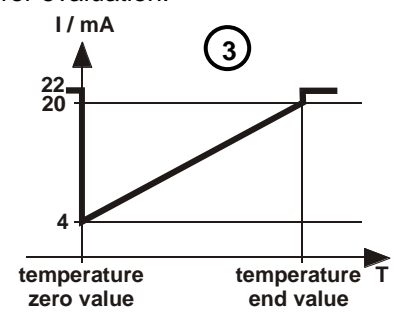
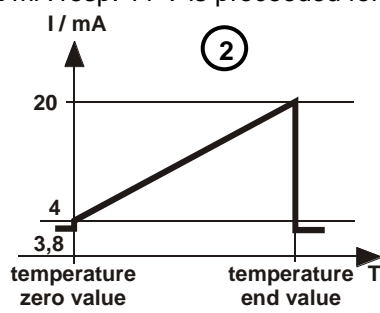
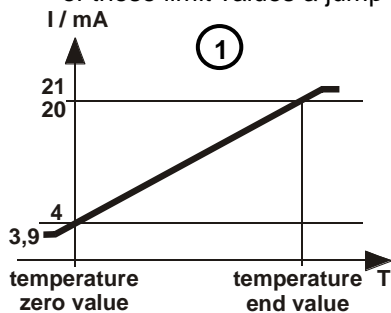

At an adjustment by *Zero – with signal resp. Span – with signal*, in addition to the shift of temperature zero value resp. the temperature end value, there can be arbitrarily shift the zero value (4 mA / 0 V) resp. the end value (20 mA / 10 V) of the analogue output in the range from 3,9 to 21 mA resp. 0...10,5 V.

An inverting of the signal can be done by the extension menu at the menu item signal inversion.

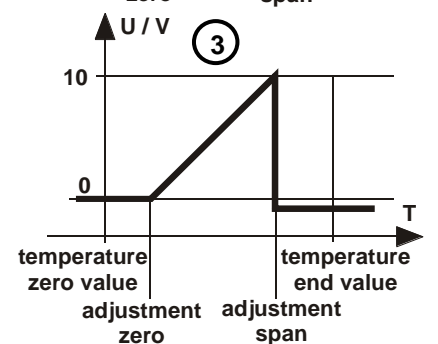
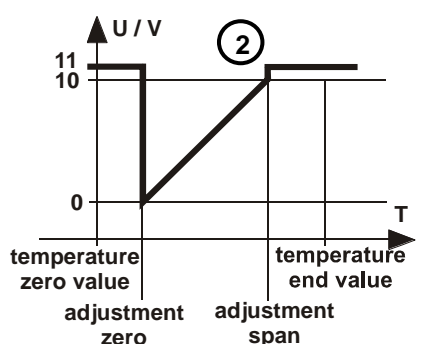
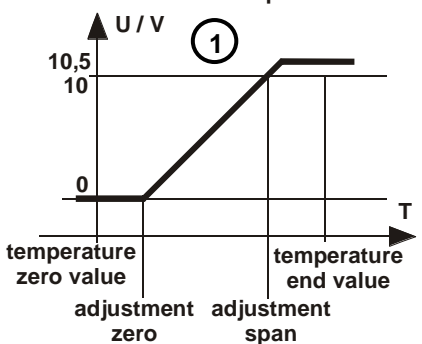
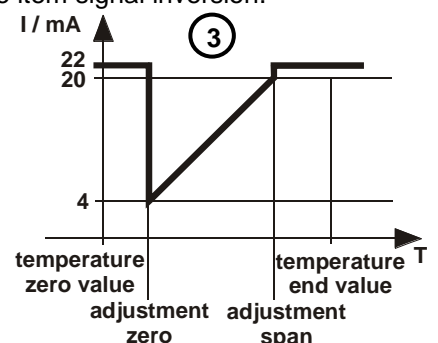
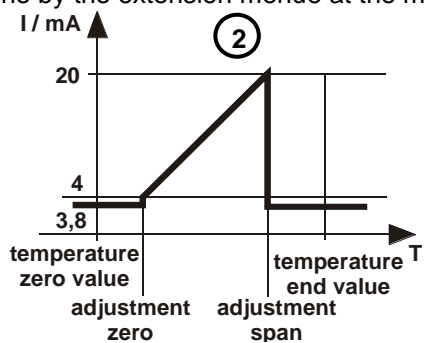
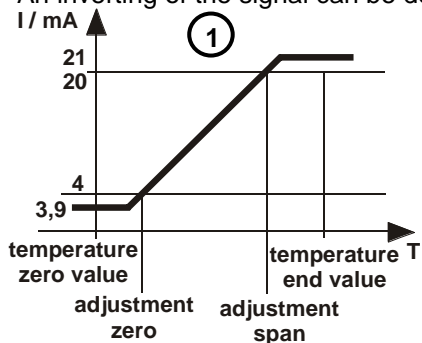

PNP – switching output

The switching function realizes a stable switching condition, independent from system conditioned temperature fluctuations around the adjusted set point.

It can also be used for realizing a temperature controlled two-position control.

The switching range is determined separately by the switch point – SP – and hysteresis – HYS – for the respective switching output.

For the switch point as well as for the hysteresis an arbitrary value referring to the display scaling can be input.

The switch back point result from switch point deducting hysteresis, as equation $SP - Hys$.

There is no default minimum value for hysteresis, that means the distance between switch resp. switch back point.

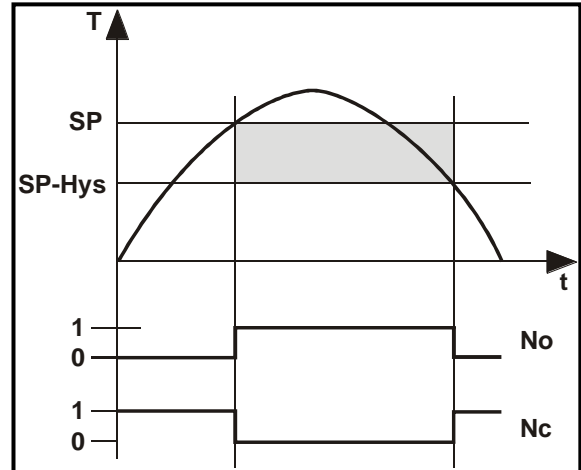

The working principle can be set separately for each switching output to:

open-circuit principle resp. no normally open or to closed-circuit principle resp. nc normally closed

The switching output S1 can be also used for error indication function alternatively to the limit value function. Doing this a switching action happens, if the output signal becomes higher than 20mA/10V resp. lower than 4mA/0V.

Damping

The damping influences the reaction speed of display, output signal and switching output at a change of the temperature.

The behaviour of display and output signal follows an exponential characteristic with the damping time constant τ . Within the time period τ the output signal increases respectively by 63% of the existing deviation.

With 99,3%, the end value is nearly achieved after 5τ .

The damping can be adjusted from 0...60 seconds in 100 steps from 0...100, whereby one step equals 0,6 seconds.

The set time (value x 0,6 seconds) equals 5τ .

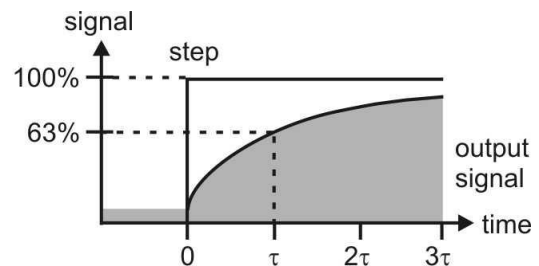

Function scheme

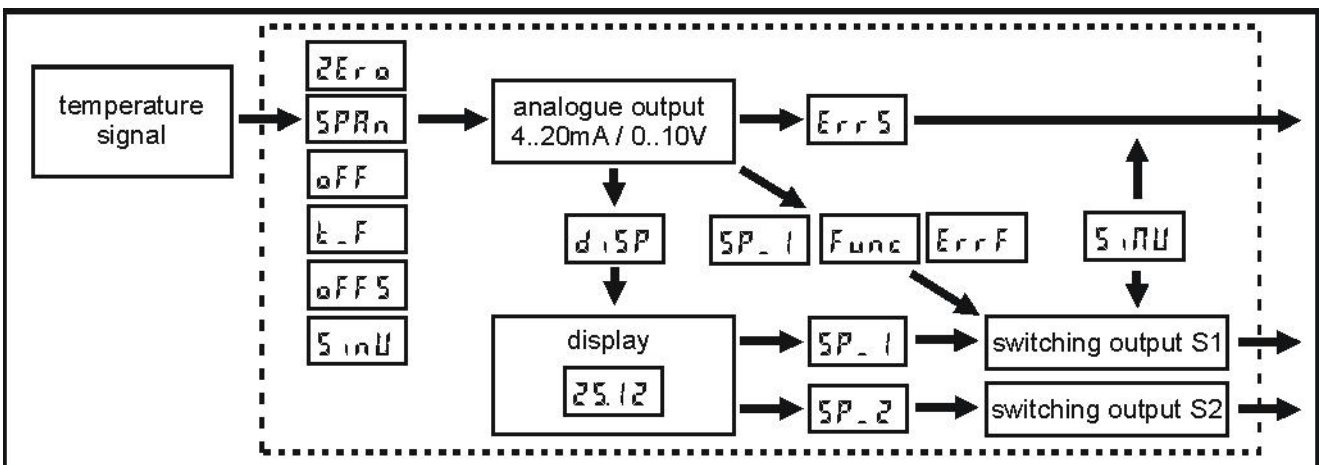

Adjustment menu – password 3009

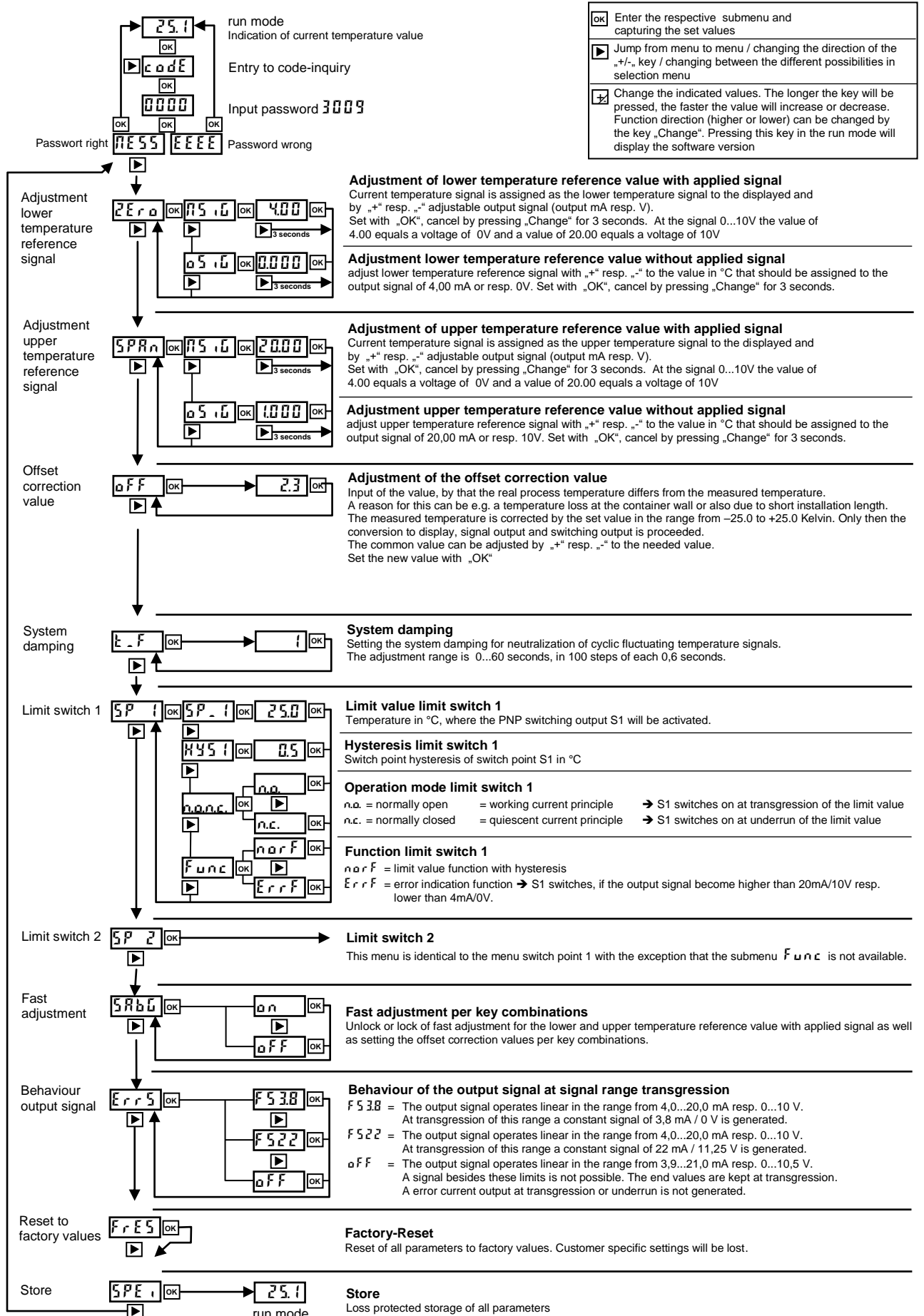

Extension menu – password 2812

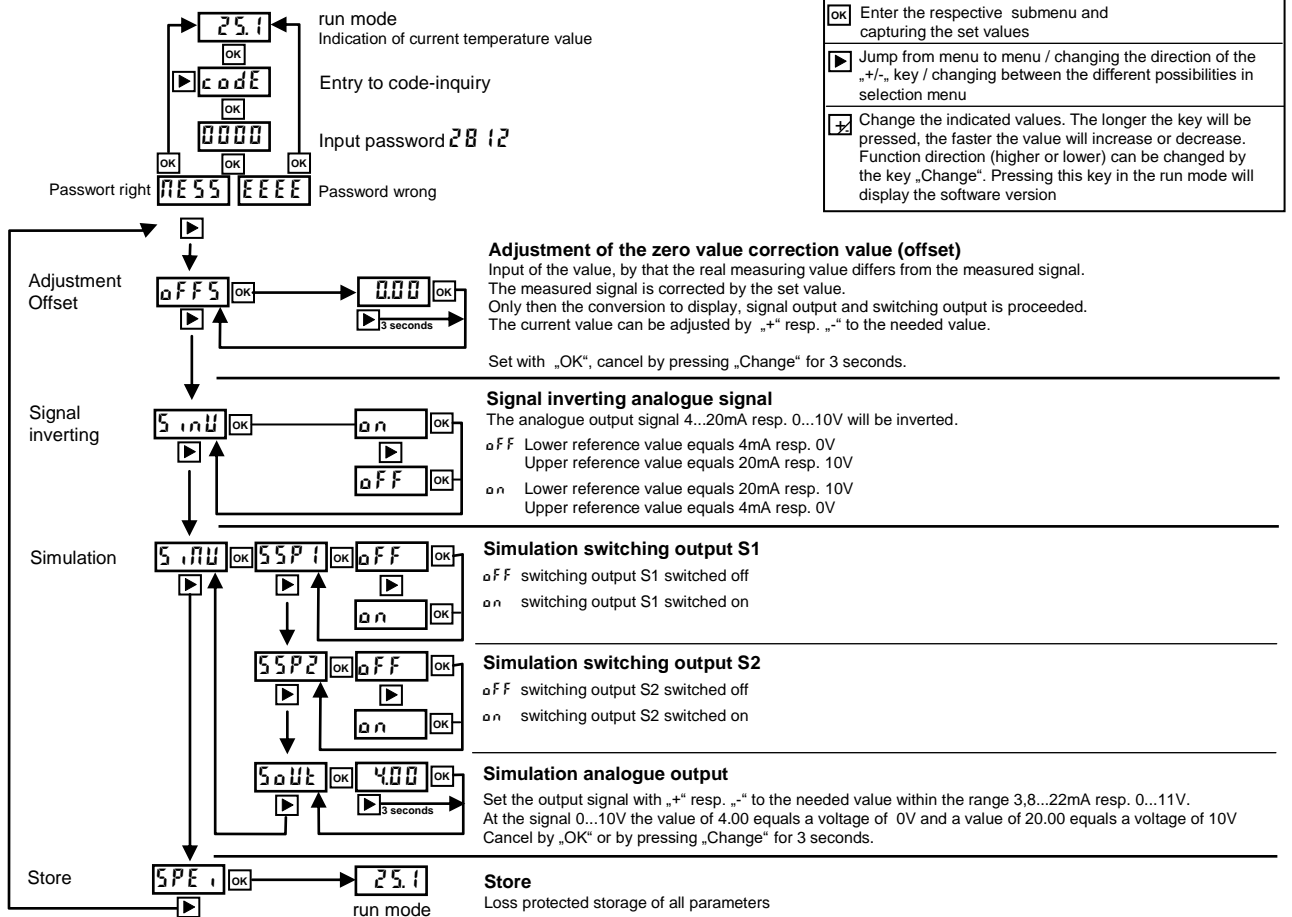

OK	Enter the respective submenu and capturing the set values
▶	Jump from menu to menu / changing the direction of the „+/-“ key / changing between the different possibilities in selection menu
▶	Change the indicated values. The longer the key will be pressed, the faster the value will increase or decrease. Function direction (higher or lower) can be changed by the key „Change“. Pressing this key in the run mode will display the software version

Technical data

Auxiliary supply

Permitted supply voltage:	reverse polarity protected 14,5...45 V DC	Ex	14,5...30 V DC
Ripple voltage:	$\leq 2 V_{PP}$	condition:	within the permitted supply voltage range
Supply current:	2-wire 4...20 mA ≤ 22 mA 3-wire 0...10 V ≤ 10 mA		PNP switching outputs no load PNP switching outputs no load

Analogue output 4...20 mA

Signal range:	linear characteristic from 3,9...21 mA resp. 21...3,9 mA error signal 3,8 mA / 22 mA
Permitted load:	$R_L \max = (V_{S \text{ act.}} - 14,5) / 20\text{mA}$
Resolution:	$\leq 1 \mu\text{A}$
Minimum delay time:	≤ 35 ms typ. (max. 70 ms) at set system damping 0
Influence of supply voltage:	$\leq \pm 0,02\% \text{ FS}^2) / 10\text{V}$

Analogue output 0...10 V

Signal range:	linear characteristic from $\leq 0,01...10,5$ V resp. $10,5... \leq 0,01$ V error signal $\leq 0,01$ V / 11,25 V
Permitted load:	$R_L \geq 2000 \Omega$, equals 5 mA at signal 10 V, current limited
Resolution:	$\leq 0,5$ mV
Minimum delay time:	≤ 35 ms typ. (max. 70 ms) at set system damping 0
Influence of supply voltage:	$\leq \pm 0,02\% \text{ FS}^2) / 10\text{V}$

PNP switching output

Function:	PNP switching to +Vs
Output voltage:	$V_{OUT} \geq +Vs - 2$ V
Output current:	≤ 250 mA, min. 200 mA current limited, short circuit protected
Rise up time:	$\leq 700 \mu\text{s}$ output load $\leq 3000 \Omega$ resp. $\geq 4,5$ mA
Delay time:	≤ 35 ms typ. (max. 70 ms) at set system damping 0
Switching cycles:	$\geq 100.000.000$

²⁾ Referring to nominal measuring span resp. full scale (FS)

Measuring accuracy

Limit value deviation ^{6) 12)}:

Display and switching output

$\leq \pm (0,2 \text{ K} + \text{deviation Pt100})$

$\leq \pm 0,2 \text{ K}$ at version accuracy class type Y - calibration

Analogue output:

$\leq \pm (\text{Measuring deviation display and switching output} + 0,1\% \text{ FS}^2)$

e.g. $\leq \pm 0,85 \text{ K}$ at $+100^\circ\text{C}$ / class A / range $-50..+200^\circ\text{C}$ / $\text{TD}^7) = 1$

at analogue output 0...10V zero value deviation $\leq +0,01 \text{ V}$

Deviation Pt100:

Class A:

0°C +/- 0,15 K

$[\text{t}]^\circ\text{C}$ +/- (0,15 K + 0,002 K * [t]) with [t] without sign, in K

Class B:

0°C +/- 0,30 K

$[\text{t}]^\circ\text{C}$ +/- (0,30 K + 0,005 K * [t]) with [t] without sign, in K

Class AA:

0°C +/- 0,10 K

$[\text{t}]^\circ\text{C}$ +/- (0,10 K + $1/3 * 0,005 \text{ K} * [\text{t}]$) with [t] without sign, in K

Characteristic deviation ^{3) 5) 6) 12)}:

$\leq \pm 0,2 \text{ K}$

Non-reproducibility ^{6) 12)}:

$\leq \pm 0,1 \text{ K}$

Hysteresis ^{6) 12)}:

negligible

Long term drift ^{6) 12)}:

$\leq \pm 0,1 \text{ K}^8) / \text{year}$ not cumulative

Temperature deviation ^{6) 12)}:

Display and switching output:

$\leq \pm 0,03\% \text{ FS}^2) / 10 \text{ K}$

Analogue output:

$\leq \pm 0,05\% \text{ FS}^2) / 10 \text{ K}$

Response time ⁹⁾:

$t_{90} \leq 37 \text{ s}$ at sensor tube diameter 6 mm

$t_{90} \leq 49 \text{ s}$ at sensor tube diameter 8 mm

$t_{90} \leq 55 \text{ s}$ at sensor tube diameter 10 mm

$t_{90} \leq 18 \text{ s}$ at reduced tip 3 mm

$t_{90} \leq 21 \text{ s}$ at reduced tip 5 mm

$t_{90} \leq 37 \text{ s}$ at reduced tip 6 mm

²⁾ Referring to nominal measuring span resp. full scale (FS)

³⁾ Nonlinearity + Hysteresis + Reproducibility

⁵⁾ Limit value adjustment

⁶⁾ Specification valid, if adjusted measuring range = nominal measuring range, i.e. for $\text{TD}^7) = 1$
At $\text{TD}^7) \geq 1$ (adjusted measuring range \leq nominal measuring range):

⁷⁾ Specification at adjusted measuring range = specification at nominal measuring range x $\text{TD}^7)$
Turn-Down $\text{TD} = \text{nominal measuring range (FS}^2) / \text{adjusted measuring range}$

⁸⁾ At reference conditions

⁹⁾ According to EN/IEC 60751 / water / 0,4 m/s / temperature step 23 to 33°C

¹²⁾ Higher values for special measuring range

Materials

Sensor tube: (medium contact)	Steel 1.4404 (AISI 316L) / 1.4571 (AISI 316Ti)	
Process connection: (medium contact)	Steel 1.4404 (AISI 316L) / 1.4571 (AISI 316Ti)	
Neck tube:	CrNi-steel	
Connection housing:	CrNi-steel / PBT polybutyleneterephthalat / PP – polypropylene / POM – polyoxymethylene (Delrin®)	
Display window:	PC – polycarbonate (Makrolon®)	
Device plug M12x1:	Socket CrNi-steel, insert PUR, contacts gold-plated	
Connection cable:	PE – polyethylene	
Cable gland:	Housing PA – polyamide, gasket CR / NBR	
Pressure compens. element:	Housing PA – polyamide, membrane ePTFE	
Membrane keyboard:	PES – polyester	
Gaskets:	medium contact	➔ FPM – fluorelastomere (Viton®) EPDM – etylene-propylene-dienmonomere
	others	➔ FPM – fluorelastomere (Viton®) Silicone

Environmental conditions

Environmental temperature: – 40°C...+85°C, limitation at Ex variants

additional limitations by material	Environmental temperature range
Connection housing PBT	-25...+85°C
Connection housing PP	-10...+85°C
Connection cable PE	-40...+70°C

Process temperatures: Variant temperature range type 2 -50...+200°C
maximum – 70°C...+230°C
Variant temperature range type 3 -100...+500°C
maximum – 130°C...+530°C

additional limitations by material	Process temperature range
Process connection type 4 - gasket FPM	-25...+140°C
Process connection type 5 - gasket EPDM	-40...+130°C

Process pressure ranges: depends on variant process connection, maximum – 1 bar ...60 bar

Weight: depends on variant

Torque strength:	≤ 50 Nm	at process connections with screw-in thread
Protection classification:	IP67	EN/IEC 60592
Climatic classification:	4K4H	EN/IEC 60721-3
Vibration classification	4 g	5 - 100 Hz
EM – compatibility:	emission	EN/IEC 61326-1 operation device class B
	immunity	EN/IEC 61326-1 industrial range
Reference conditions:	EN/IEC 60770-1	T = 15...35 °C, relative humidity 45...75 %, environmental air pressure 860...1060 kPa

Dimension drawings

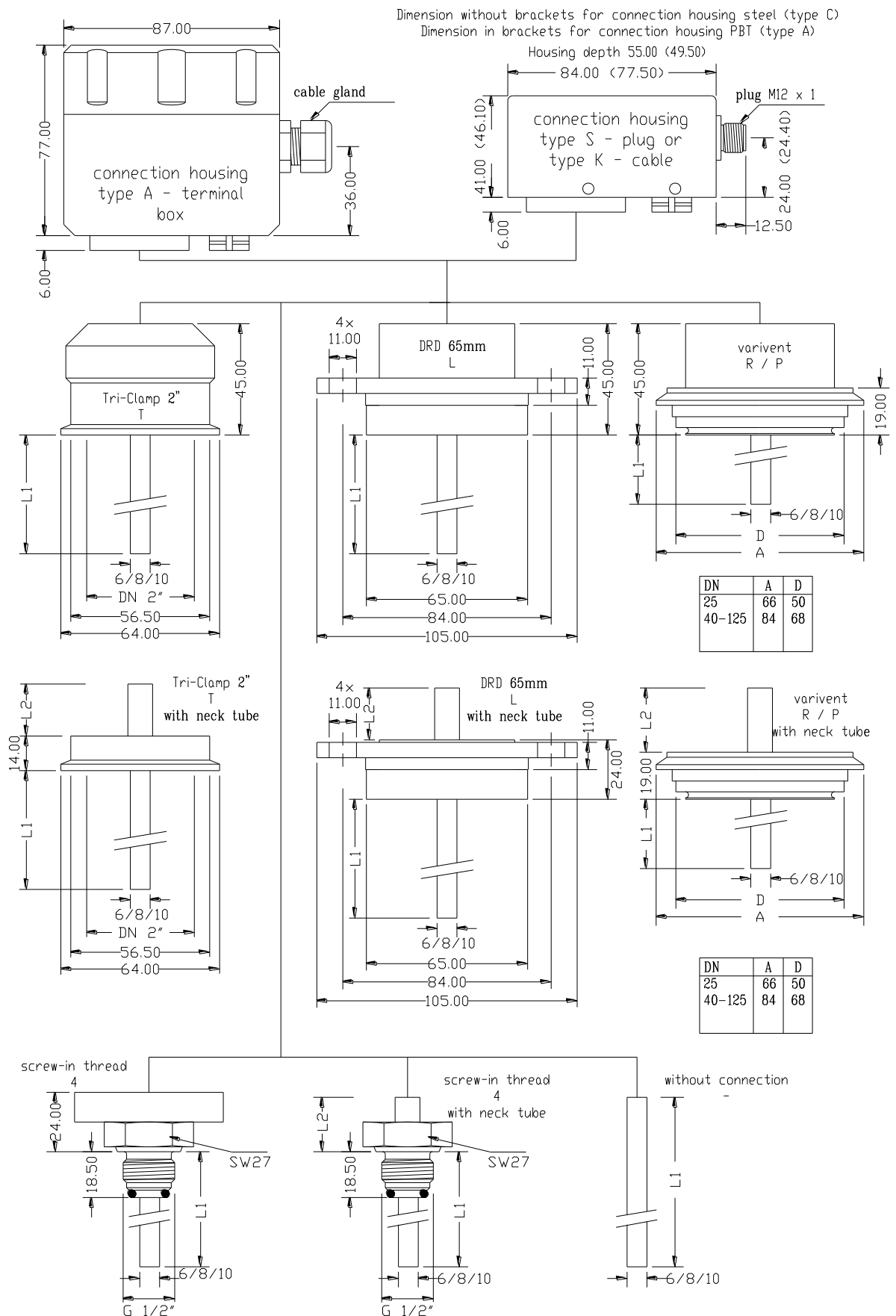

Dimension drawings

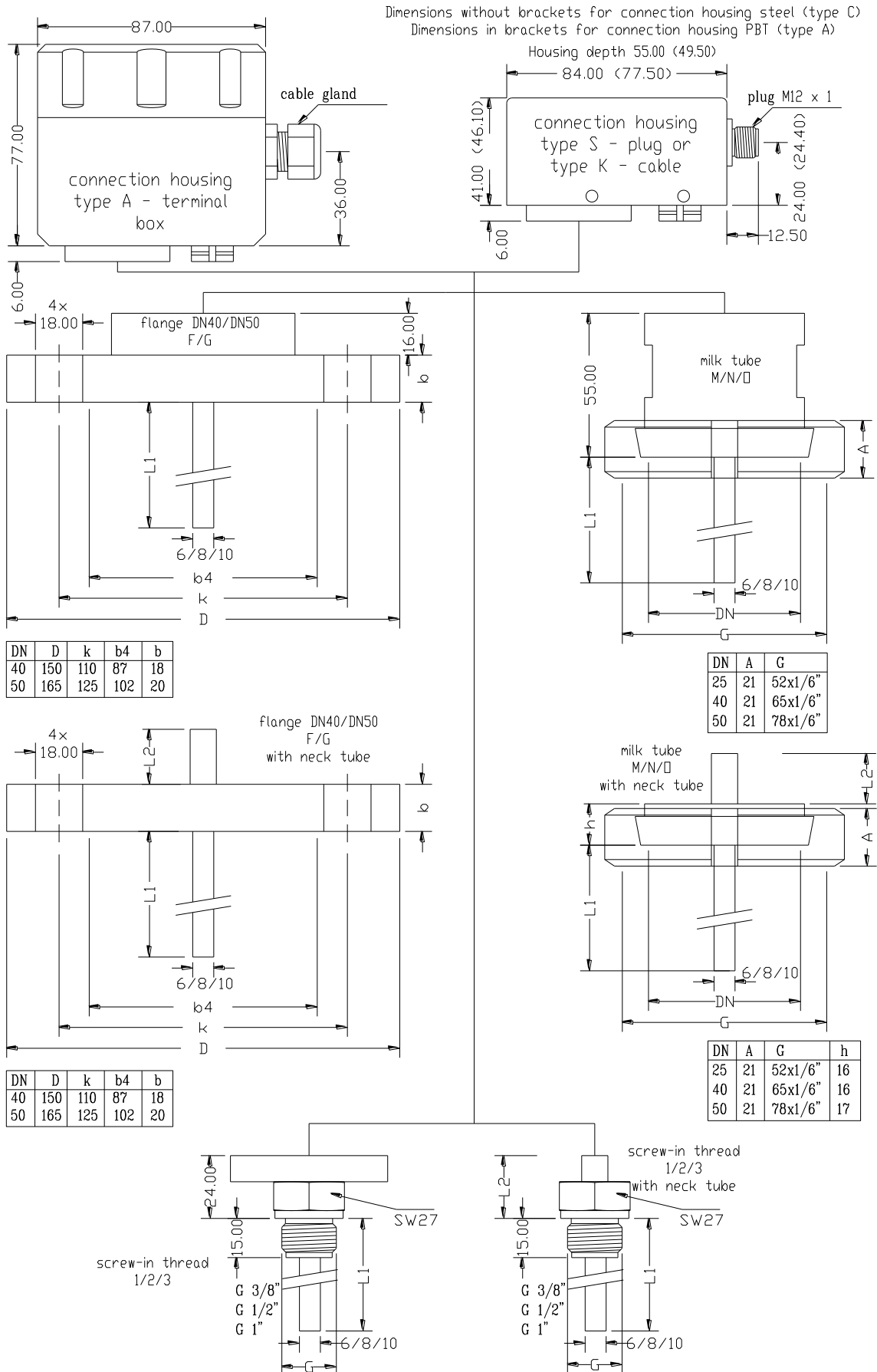

Order code overview

Digital temperature transmitter with **resistance temperature sensor Pt100** from -100 to 500°C

Type:

- ST Standard
- ExST ATEX II 1/2 G Ex ia IIC T4 Ga
- XDST ATEX II 1/2 D Ex ia IIIC T85°C/T102°C Da/Db resp. ATEX II 1/2 G Ex ia IIC T4 Ga
only with connection housing type C

Measuring range:

- 2 -50°C to +200°C
- 3 -100°C to +500°C
- Y special measuring range separate spec. necessary

Accuracy class Pt100:

- B Class B
- A Class A
- C Class 1/3 DIN B
- Y Calibration

Process connection material steel 1.4404 (AISI316L) / 1.4571 (AISI316Ti) (medium contact):

- 1 G 1/2" B ISO228-1
- 2 G 1" B ISO228-1
- 3 G 3/8" B ISO228-1
- 4 G 1/2" B ISO228-1 O-ring-gasket FPM front flush
- 5 G 1/2" B ISO228-1 O-ring-gasket EPDM front flush
- 6 G 1/2" B ISO228-1 metallic sealing
- M Milk tube DN 50, PN 25 DIN 11851
- N Milk tube DN 40, PN 40 DIN 11851
- O Milk tube DN 25, PN 40 DIN 11851
- R Varivent 50 mm DN25/DN1", PN25
- P Varivent 68 mm DN40-80/DN1 1/2" ..6", PN25 DN100/DN4", PN20 DN125/DN6", PN10
- L DRD 65 mm DN 50, PN 25
- F Flange DN 40, PN 10-40 DIN EN 1092-1 sealing surface DIN 2527-D
- G Flange DN 50, PN 10-40 DIN EN 1092-1 sealing surface DIN 2527-D
- T Tri-clamp DN 2", PN 16 ISO 2852
- S others on request
- 0 no process connection for sliding sleeves

Sensor – diameter / material:

- K Ø 6 mm steel 1.4404 (AISI 316L) / 1.4571 (AISI 316Ti)
- N Ø 8 mm steel 1.4404 (AISI 316L) / 1.4571 (AISI 316Ti)
- L Ø 10 mm steel 1.4404 (AISI 316L) / 1.4571 (AISI 316Ti)
- M Ø 8 mm reduced tip Ø 5mm / L 40mm steel 1.4404 (AISI 316L) / 1.4571 (AISI 316Ti)
- O Ø 10 mm reduced tip Ø 6mm / L 40mm steel 1.4404 (AISI 316L) / 1.4571 (AISI 316Ti)
- R Ø 8 mm reduced tip Ø 3mm / L 40mm steel 1.4404 (AISI 316L) / 1.4571 (AISI 316Ti)
- S others on request

Neck tube:

- A without neck tube
- B with neck tube Ø 10 mm, L2 = 110mm
- S with neck tube Ø 10 mm, L2 by separate specification

Material connection housing:

- A PBT – polybutyleneterephthalat not for electrical connection type A
- C CrNi-steel
- E PP – polypropylene not for electrical connection type S
- D POM – polyoxymethylene (Delrin®) not for electrical connection type S

Electrical connection:

- S Plug M12x1
- K Cable 2m
- A Terminal box

Electronic - output:

- A 2-wire-technology signal 4...20 mA 2x PNP switching output
- B 2-wire-technology signal 4...20 mA
- E 3-wire-technology signal 0...10 V 2x PNP switching output
- F 3-wire-technology signal 0...10 V

Length L1 – sensor in mm:

Length L2 – neck tube in mm:

Thermocont