



fill level



water level



pressure



temperature



flow



visualization



signal converter



sensoric



Sonicont USF2

Ultrasonic level indicator

Displaying, monitoring and processing of ultrasonic level signals

Technical manual
08.18

Applications

Non-contact level and volume measurement or flow measurement at open channels and measuring weirs for

- Water and waste water sector
- Process industry
- Environmental technology
- Storage tanks, storage bunkers, silos

Main features

Wide range of applications

- Measuring ranges up to 25m in liquids and bulk materials
- Installation on the wall, into front panel or onto DIN-rail
- High protection class up to IP65
- Wide environmental temperature range -20°C to $+60^{\circ}\text{C}$
- Certification ATEX II (1) G [Ex ia Ga] IIC / ATEX II (1) D [Ex ia Da] IIIC

Level indicator can be installed up to 300m from the level transmitter

High accuracy – characteristic deviation $\leq 0,2\%$ of measuring range

Extensive equipment

- Graphic display, keyboard
- 4x relay switch output
- 1x current output 0/4...20mA – voltage output 0...10V
- 4x digital input
- Interface USB 2.0
- Wireless interface Bluetooth 2.1 + EDR
- Measure data memory for more than 500.000 measuring values

- Battery powered data logger function

High operating comfort

- High contrast high brightness TFT-LCD display for best readability
- 3-key operation without additional assistance with tactile feedback
- Easy handling by clear menu navigation
- Extensive diagnostic functions for system analysis

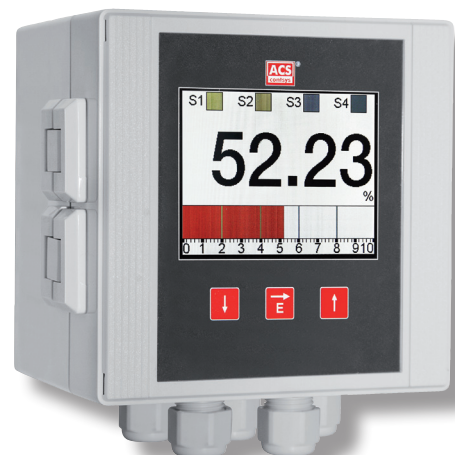

ACS-CONTROL-SYSTEM
knowledge and systems



Your partner for measuring technology and automation

You have purchased a high-grade and modern measuring device of ACS-CONTROL-SYSTEM GmbH.

We want to give thanks for your purchase and for your confidence to us.

The actual technical manual includes instructions for installation, electrical connection and inauguration, as well as the technical data of the device.

Modifications, that answer the purpose of the technical progress, are reserved by ACS-CONTROL-SYSTEM GmbH without prior notice.

If a question occurs, that can't be answered by the listed informations, please call on our technicians team in Eggenfelden Tel: +49 8721/ 9668-0 or info@acs-controlsystem.de

All rights reserved

1 Index

1 System description	4
1.1 Intended use	4
1.2 Field of application	4
1.3 System components	4
1.4 Function	5
2 Safety notes	6
2.1 Operational safety	6
2.2 Installation, connection, commissioning, operation	6
2.3 Operating supplies for explosive hazardous areas .	6
3 Installation	7
3.1 Installation place	7
3.2 Installation notes	7
4 Electrical connection	8
4.1 Terminal assignment	8
4.2 Potential equalization - earthing	9
4.3 Connection cable	9
4.4 Supply voltage	10
4.5 Signal input sensor – InA1	11
4.6 Signal output U/I – OutA1	11
4.7 Switch output – S1/S2/S3/S4	12
4.8 Digital status output – InD1/2/3/4	13
4.9 Digital control input – SYNC	13
5 Operation	14
5.1 Operation and display parts	14
5.2 Function scheme	15
5.3 Menu structure	17
5.4 Navigation	18
5.5 Input	19
5.6 Output	20
5.7 Basic Setting	28
5.8 Display	32
5.9 Simulation – extended menu structure	37
5.10 Diagnose	38
5.11 Data	41
5.12 Start-up procedure	44
5.13 Software history	47
6 Service	48
6.1 Maintenance	48
6.2 Dismounting	48
6.3 Repair	48
6.4 Return	48
6.5 Disposal	48
7 Technical Data	49
7.1 Auxiliary power supply	49
7.2 Input	49
7.3 Output	50
7.4 Measuring accuracy	50
7.5 Interface	51
7.6 Data memory	51
7.7 Clock	51
7.8 Environmental conditions	51
7.9 Materials	52
8 Dimension drawings	53
8.1 Terminal enclosure	53
9 Ordering information	56
9.1 Order code	56
9.2 Additional options	57
9.3 Accessories	57

1 System description

1.1 Intended use

The device is an electronic level indicator for ultrasonic sensors for displaying, monitoring as well as processing of levels of liquids, pastes or coarse bulk materials.

The operational reliability of the device is ensured only at the intended use.

1.2 Field of application

Due to the device construction with

- Enclosure types for installation on the wall, into front panel or onto DIN-rail
- High protection and wide environmental temperature range for outside use
- Installation of the indicator up to 300m from the measurement place
- Connection of a ultrasonic level sensor with measuring ranges up to 25m
- ATEX certification ATEX II (1) G / ATEX II (1) D

as well as the availability of extensive equipment and functionality

- Predefined vessel types for fast commissioning
- Predefined linearization curves for volume and flow measurement
- Integrated error signal suppression for adaption the installation situation
- Integrated compensation of the process temperature
- Limit value function for two-point control
- Pump control function with pump monitoring by digital inputs
- Impulse output function for quantity counter
- Error indication function for error monitoring

the device is especially suitable for the use for

- Level and volume measurement
- Flow measurement at open channels and measuring weirs

for

- Water and waste water sector
- Process industry
- Environmental technology
- Storage tanks, storage bunkers, silos

The level indicator is suitable for simple as well as for demanding measuring requirements.

Due to its high accuracy and the high flexibility of configuration, the device can be suited a wide variety of applications.

A captive laser marking of the type label at the enclosure types for wall installation resp. for installation onto DIN-rail ensures the identifiability throughout the entire lifetime of the device. Obviously is the optional marking of a measurement point designation resp. TAG, a customer label or of a neutral type label, at the enclosure types for wall installation resp. for installation onto DIN-rail of course also per laser marking.

A customer specific configuration resp. preset is optionally available.

Customer specific special versions can be realized on request, e.g.

- software adaption (menu navigation, special functions, etc.),
- design adaption of the user surface

1.3 System components

The device consists on the components:

- Terminal enclosure, for installation on the wall, into front panel or onto DIN-rail and for protection of the integrated signal processing electronic
- Signal processing electronic, with display and keyboard
- Terminal area, for the electrical connection.

The components cannot be separated by the user.

1.4 Function

1.4.1 Measuring principle

The transducer of the ultrasonic sensor transmits ultrasonic pulses to the product surface. These pulses are reflected by product surface and received back by the transducer as echoes.

The running time of the ultrasonic pulses from emission to reception is proportional to the distance and hence the level.

Because the running time of the ultrasonic pulses is highly dependent on the environmental temperature, the temperature dependent change of sound velocity must be compensated. A temperature sensor, which is integrated in the ultrasonic sensor, is used for the temperature measurement.

1.4.2 Signal processing

The running time determined level is processed by the integrated evaluation electronic according to the respective preferences:

- The measuring value is diagrammed at the high brightness and high contrast TFT-LCD display, whereby it can be selected between different display styles (digital value / manometer / chart / bar graph).
- The measuring value is monitored by four relay switch outputs for exceedance of limit values.
- The measuring value is converted into a galvanically isolated continuous current signal 0/4...20mA or voltage signal 0...10V.
- All settings can be changed comfortable and easy by a 3-key operation with tactile feedback.

The device includes numerous functions to the adaption to nearly each measuring task:

- The interference echo suppression function ensures that interference echoes (e.g. from edges, welded joints and installations) are not interpreted as a level signal.
- Integrated unit conversion
- Peak value memory minimum – maximum
- Error memory for fast failure analysis
- Various flexible relay functions
- Error indication function to switch output, current/voltage output and display
- Simulation of the relay switch outputs and the current/voltage output

In the internal ring memory more than 500.000 measuring values can be recorded durable.

At the data logger function these measuring values are marked with a battery powered time stamp.

By the USB resp. the Bluetooth interface recorded measuring values can be downloaded.

At the USB interface the connection of a standard USB data storage device (USB flash drive) with Micro-USB plug is possible. External USB-A-Receptacles are optionally available.

2 Safety notes

2.1 Operational safety

The device is safely built and tested according to state-of-the-art technology and has left the factory in perfect condition as regards technical safety.

The device meets the legal requirements of all relevant EU directives. This is confirmed by attaching the CE mark.

2.2 Installation, connection, commissioning, operation

Installation, electrical connection, commissioning and operation of the device must be made by a qualified and authorized expert according to the information's in this technical manual and the relevant standards and rules. This expert must have read and understood this technical manual and especially the safety notes.

The device may only be used within the permitted operation limits that are listed in this technical manual. Every use besides these limits as agreed can lead to serious dangers.

The materials of the device must be checked for compatibility with the respective application requirements (contacting materials, process temperature) before use. An unsuitable material can lead to damage, abnormal behavior or destruction of the device and to the resulting dangers.

The sensors may not be used as sole device for prevention of dangerous conditions in machines and plants.

Using the device in a manner that does not fall within the scope of its intended use, disregarding this instruction, using under-qualified personnel, or making unauthorized alterations releases the manufacturer from liability for any resulting damage. This renders the manufacturer's warranty null and void.

2.3 Operating supplies for explosive hazardous areas

If a device is installed and operated in explosive hazardous areas, the general Ex construction standards (EN/IEC 60079-14, VDE 0165), these safety notes and the enclosed EC conformity certificate incl. supplements must be observed.

The installation of explosive hazardous systems must be carried out principally by specialist staff.

The device meets the classification:

ATEX II (1) G [Ex ia Ga] IIC ATEX II (1) D [Ex ia Da] IIIC	$T_a = -20...+60^{\circ}\text{C}$
---	-----------------------------------

The devices are conceived for connection of sensors in explosive hazardous areas, that needs devices of category 1 resp. 1/2 resp. 2.

The measured medium of the sensors may also be combustible liquids, gases, fogs or vapors.

If the intrinsically safe input circuit is run into dust explosion hazardous areas zone 20 resp. 21, it must be ensured, that the devices, that are connected to this circuit, fulfills the requirements for category 1D resp. 2D and are certificated accordingly.

The device is an affiliated operating supply and may only be used outside explosion hazardous areas.

The intrinsically safe input circuits are galvanically connected with earthing potential. Due to this there must be a potential compensation in the complete area of the installed intrinsically safe circuits.

The both terminals PA (Type F/P: terminals 32, 33 resp. type M: terminals 24, 25) have to be connected with the potential equalisation in the explosion hazardous area.

The intrinsically safe input circuit (Type F/P: terminals 25, 26, 27, 28, 29, 30, 31 resp. type M: terminals 17, 18, 19, 20, 21, 22, 23) must be installed separately from all other circuits.

At mounting the device there must be paid attention, that a distance of 50mm (thread measure) to the intrinsically safe terminals is adhered.

The intrinsically safe terminals (terminals 25, 26, 27, 28, 29, 30, 31) at the type F – field enclosure and type P – DIN-rail enclosure must be covered with the enclosed protection cover.

The intrinsically safe terminals (terminals 17, 18, 19, 20, 21, 22, 23) at the type M – front panel enclosure must be covered with the enclosed cable housing.

3 Installation

The correct function of the device within the specific technical data can only be guaranteed, if the permitted environmental temperatures (see chapter „Technical data“) will not be exceeded.

3.1 Installation place

In order to avoid excessive sunlight exposure, the instrument should be mounted in a position which is protected against direct sunlight or should be supplied with a protection cover.

Do not install the instrument in the vicinity of high-voltage lines, motor lines, contactors or frequency converters. The installation regulations for high-voltage lines, motor lines, contactors or frequency converters must be observed.

3.2 Installation notes

At mounting multiple devices side by side a minimum distance of 10cm among themselves must be observed.

3.2.1 Field enclosure – type F

The enclosure can be mounted on to the wall without opening.

Therefore the lateral cover strips must be removed

The dimensions for the mounting drills can be found in the dimension drawing of the field enclosure (see chapter „Dimension drawings“).

To open the enclosure, a minimum mounting distance at the right enclosure side must be regarded.

3.2.2 Front panel enclosure – type M

For installation an opening with the dimensions 92 x 92mm must be cut into the intended mounting position (e.g. cabinet door).

Depending on the surface of the control panel a protection class of up to IP65 can be reached, by using the form gasket that is enclosed in the delivery contents. This gasket must be slid from the rear side onto the device before installing the device into the control panel.

After inserting, the device must be fixed at the rear side with two lateral fixing clips. These are enclosed in the delivery contents.

3.2.3 DIN-rail enclosure – type P

The installation is made on a DIN rail EN 60715 TH 35x7.5 or TH 37x15.

4 Electrical connection

The electrical connection of the device must be carried out according to the respective country specific standards.

Incorrect installation or adjustment could cause applicationally conditioned risks.

Attention!

At an Ex type further notes for the electrical connection within the safety notes – Electrical operating supplies for explosive hazardous areas must be observed.

Warning!

The instrument may only be installed if the supply voltage is switched off.

4.1 Terminal assignment

4.1.1 Field enclosure – type F / DIN-rail enclosure – type P

The enclosure has a separate terminal compartment. For opening the enclosure both lateral cover stripes must be removed and all 4 screws must be loosened.

After the electrical connection all 4 screws must be tightened firmly to ensure the tightness of the enclosure.

After the installation of the connection cables the cable glands which are positioned at the bottom side of the enclosure must be tightened firmly to ensure the tightness of the enclosure.

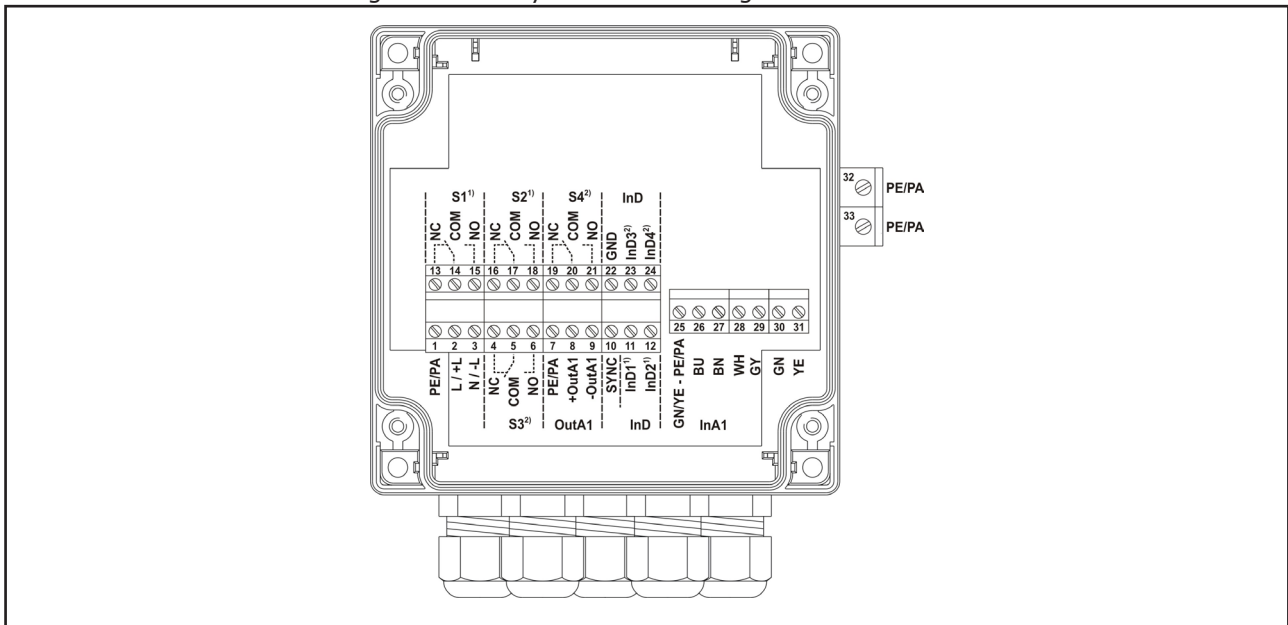

- 1) Version electronic – supply/output type B/D/T/U
- 2) Version electronic – supply/output type D/U

4.1.2 Front panel enclosure – type M

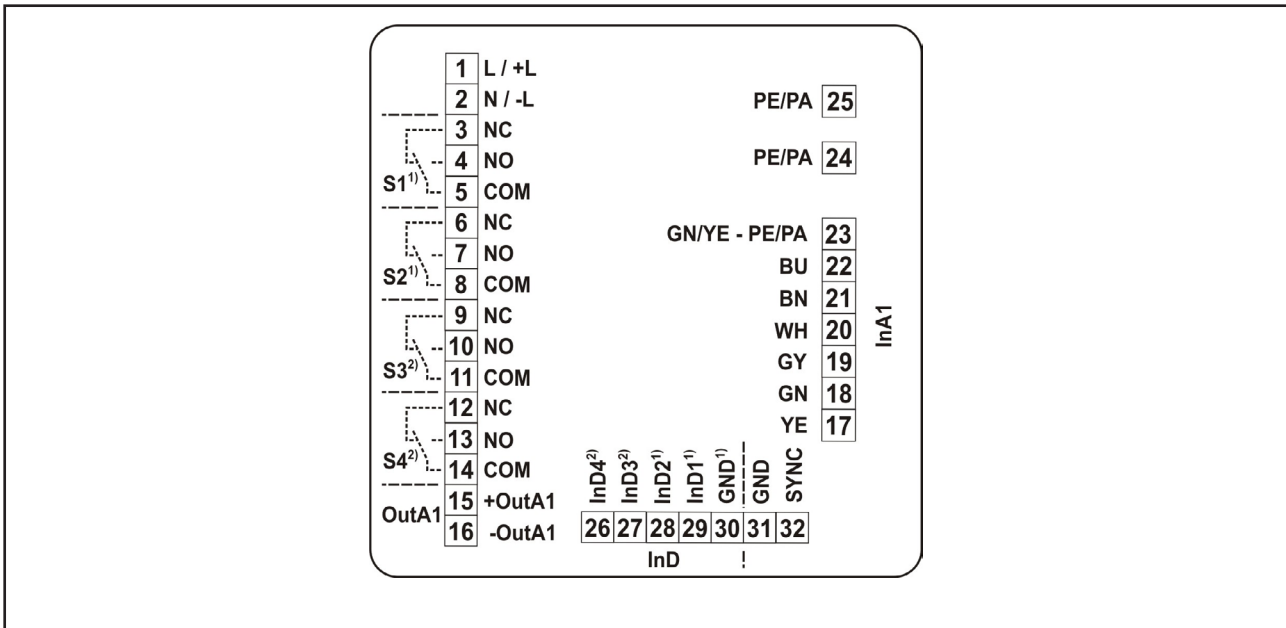

- 1) Version electronic – supply/output type B/D/T/U
- 2) Version electronic – supply/output type D/U

4.2 Potential equalization - earthing

4.2.1 Field enclosure – type F / DIN-rail enclosure – type P

The connection is made by the terminal 1 - PE/PA and by the lateral terminals 32 - PE/PA resp. 33 - PE/PA. Minimum one of the three terminals must be grounded resp. connected to the local potential equalization system.

The terminal 1 - PE/PA is internally connected to the terminal 7 – PE/PA, to the terminal 25 – PE/PA and to the lateral terminals 32 - PE/PA resp. 33 - PE/PA.

The terminal 7 – PE/PA is conceived for the connection of the cable shield of the analogue signal cable.

The terminal 25 – PE/PA is conceived for the connection of the cable shield of the input signal cable.

4.2.2 Front panel enclosure – type M

The connection is made by the metallic screw contacts 24 - PE/PA resp. 25 - PE/PA at the rear side. Minimum one of the screw contacts 24 - PE/PA resp. 25 - PE/PA at the rear side must be grounded resp. connected to the local potential equalization system.

The terminal 23 - PE/PA is internally connected to the screw contacts 24 - PE/PA resp. 25 - PE/PA at the rear.

The terminal 23 – PE/PA is conceived for the connection of the cable shield of the input signal cable.

4.3 Connection cable

The connection terminals are suitable for the connection of conductor cross sections rigid / flexible 0,5...2,5mm².

4.3.1 Field enclosure – type F / DIN-rail enclosure – type P

The lateral terminals 32 - PE/PA resp. 33 - PE/PA are suitable for the connection of conductor cross sections rigid / flexible 0,2...4mm².

The cable glands at the types field enclosure resp. DIN-rail enclosure are suitable for 4x cable diameter 4,5...10mm and 1x cable diameter 7...13mm.

4.3.2 Front panel enclosure – type M

The metallic screw contacts 24 - PE/PA resp. 25 - PE/PA at the rear side are suitable for the connection of ring cable lugs M4.

4.4 Supply voltage

The voltage applied to the terminal contacts may not exceed the maximum permitted supply voltage to avoid damage of the electronic.

4.4.1 Field enclosure – type F / DIN-rail enclosure – type P

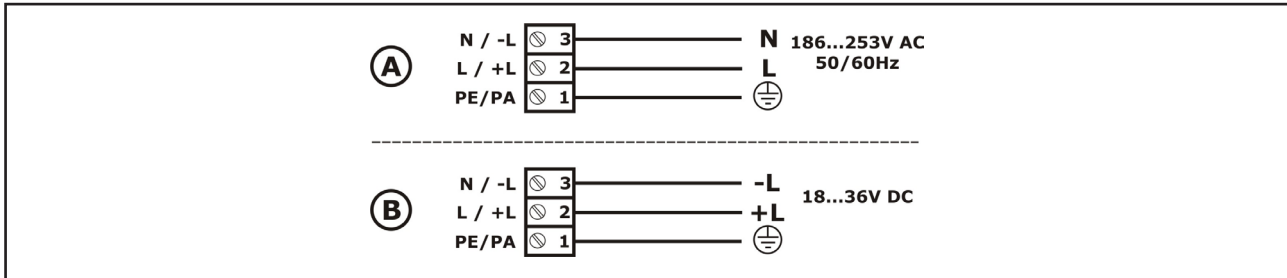

A – Version electronic – supply/output type S / T / U
The connections are reverse polarity protected.

B – Version electronic – supply/output type A / B / D

Warning!

When using the public supply mains, an easily accessible power switch must be installed in the proximity of the device.

The power switch must be marked as a disconnecter for the device (IEC/EN 61010).

4.4.2 Front panel enclosure – type M

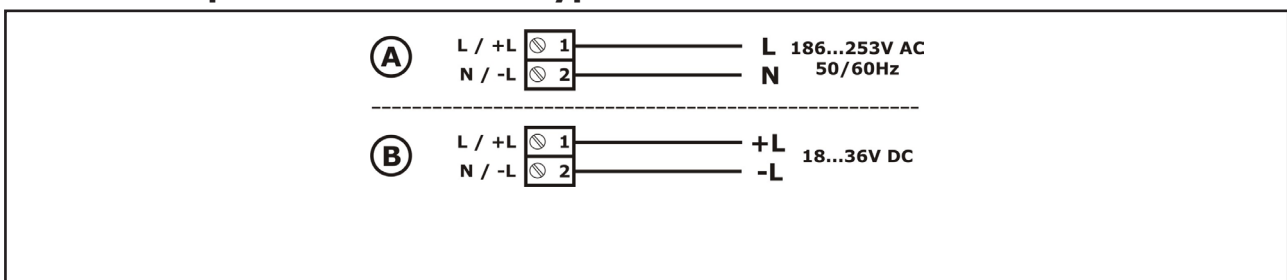

A – Version electronic – supply/output type S / T / U
The connections are reverse polarity protected.

B – Version electronic – supply/output type A / B / D

Warning!

When using the public supply mains, an easily accessible power switch must be installed in the proximity of the device.

The power switch must be marked as a disconnecter for the device (IEC/EN 61010).

4.5 Signal input sensor – InA1

In order to avoid interference signals, the sensor cable must not be laid parallel to high voltage or electric power lines.

The cable may not be laid in the proximity to frequency converters.

4.5.1 Field enclosure – type F / DIN-rail enclosure – type P

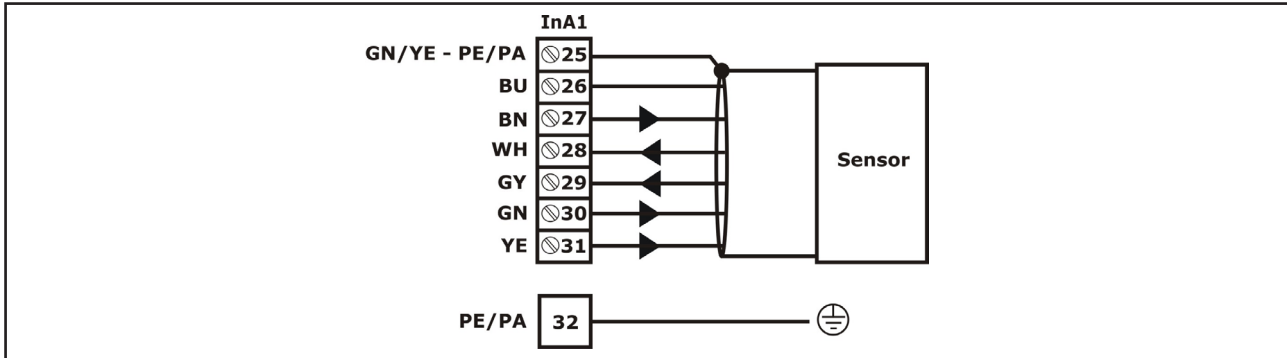

The connection of the cable shield can be made by the terminal 25 - PE/PA. This terminal is electrically connected to the lateral terminals 32 - PE/PA resp. 33 - PE/PA.

4.5.2 Front panel enclosure – type M

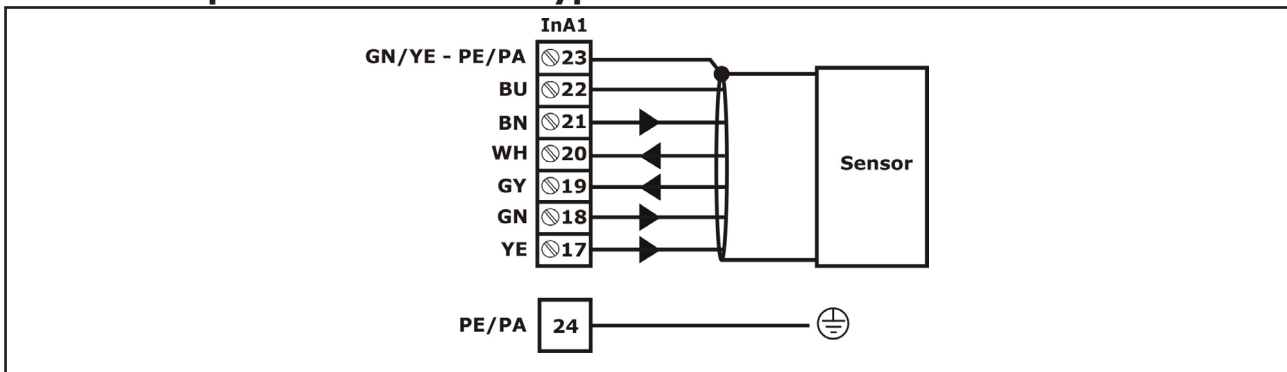

The connection of the cable shield can be made by the terminal 23 - PE/PA. This terminal is electrically connected to the metallic screw contacts 24 - PE/PA resp. 25 - PE/PA at the rear side.

4.6 Signal output U/I – OutA1

Use only shielded signal wires and install these wires separated from power leading wires. Connect the cable shield of a connected cable only at one side to earth.

4.6.1 Field enclosure – type F / DIN-rail enclosure – type P

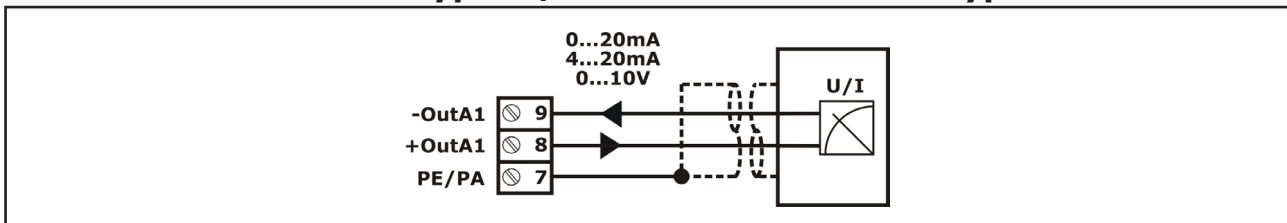

The connection of the cable shield can be made by the terminal 7 - PE/PA.

The terminal 7 - PE/PA is internally connected to the terminal 1 - PE/PA, to the terminal 25 - PE/PA and to the lateral terminals 32 - PE/PA resp. 33 - PE/PA.

4.6.2 Front panel enclosure – type M

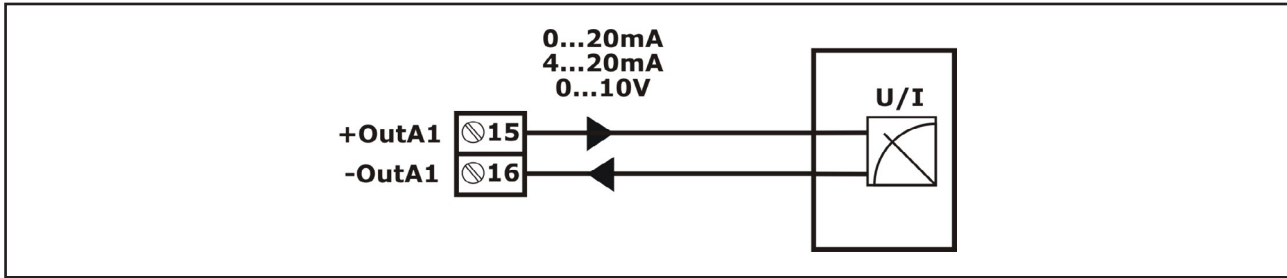

4.6.3 Load resistor

4.6.3.1 Signal output 0/4...20mA

The maximum permitted load resistor, e.g. the measuring shunt of an evaluation device, is 700Ω at a signal current 20mA resp. 636Ω at a signal current 22mA.

4.6.3.2 Signal output 0...10V

The minimum permitted load resistor, e.g. the measuring shunt of an evaluation device, is 400Ω at a signal voltage 10V resp. 440Ω at a signal voltage 11V.

4.7 Switch output – S1/S2/S3/S4

For inauguration it is suggested, to deactivate all connected control devices, to avoid unwanted control reactions.

Inductive loads at the relay contacts, e.g. auxiliary contactors or magnetic vents may only be used with a free-wheeling diode or a RC protection circuit to avoid high voltage peaks.

4.7.1 Field enclosure – type F / DIN-rail enclosure – type P

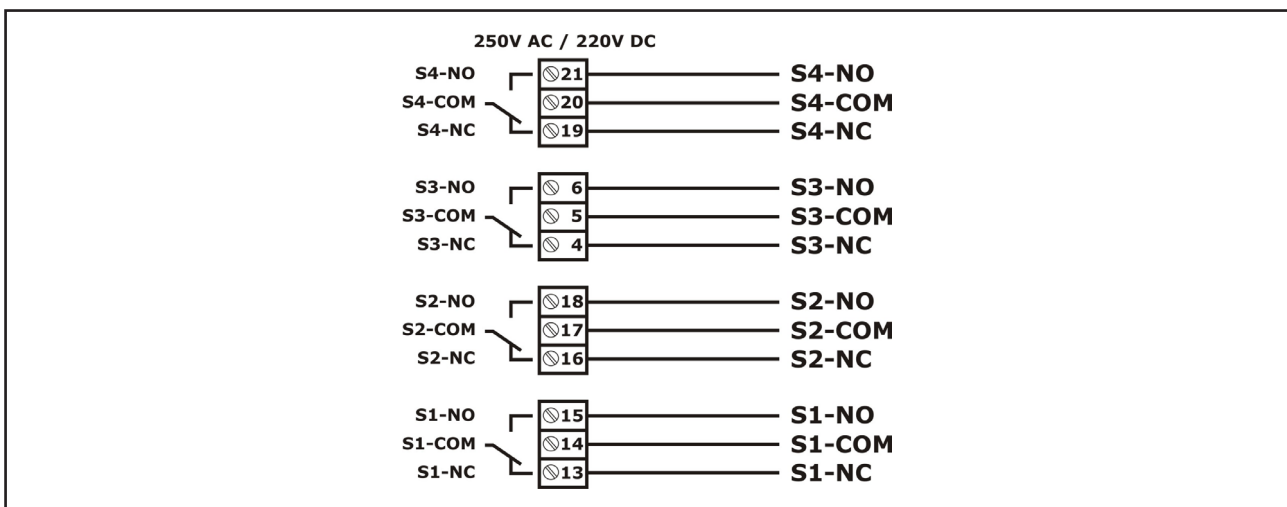

4.7.2 Front panel enclosure – type M

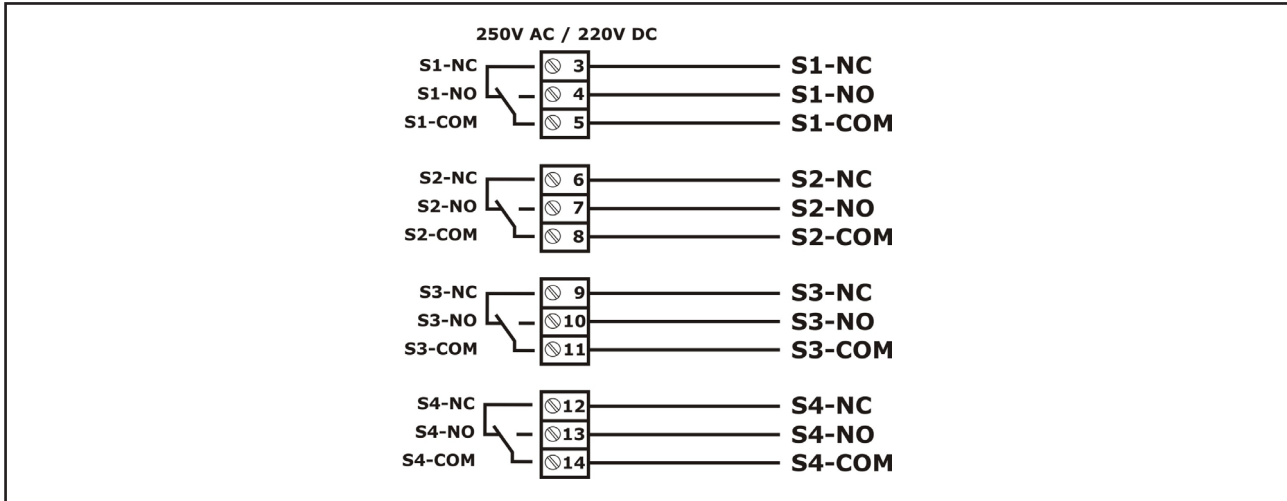

4.8 Digital status output – InD1/2/3/4

4.8.1 Field enclosure – type F / DIN-rail enclosure – type P

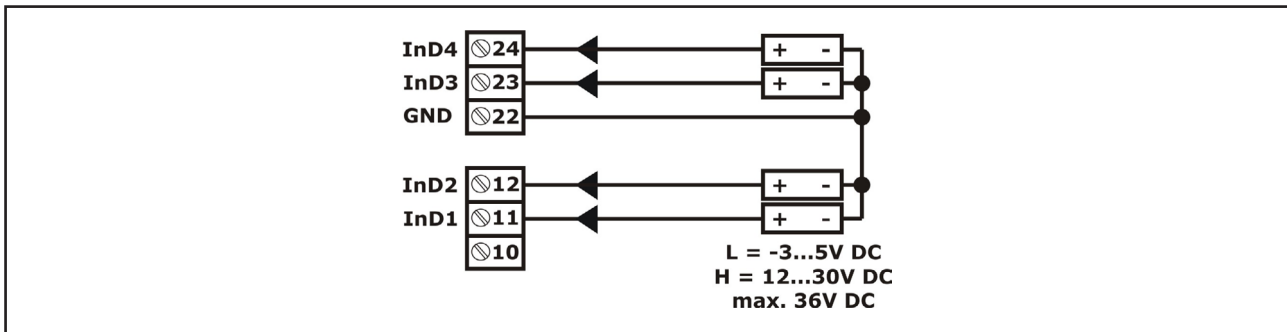

4.8.2 Front panel enclosure – type M

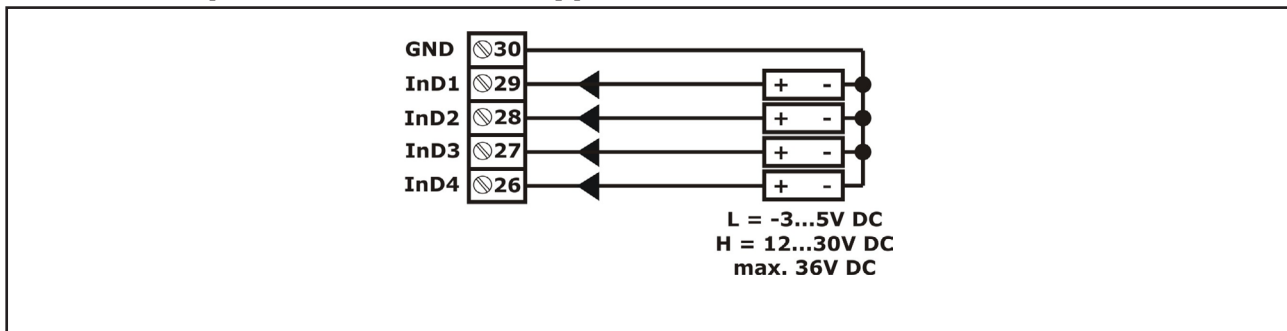

4.9 Digital control input – SYNC

This terminal is without function.

5 Operation

5.1 Operation and display parts

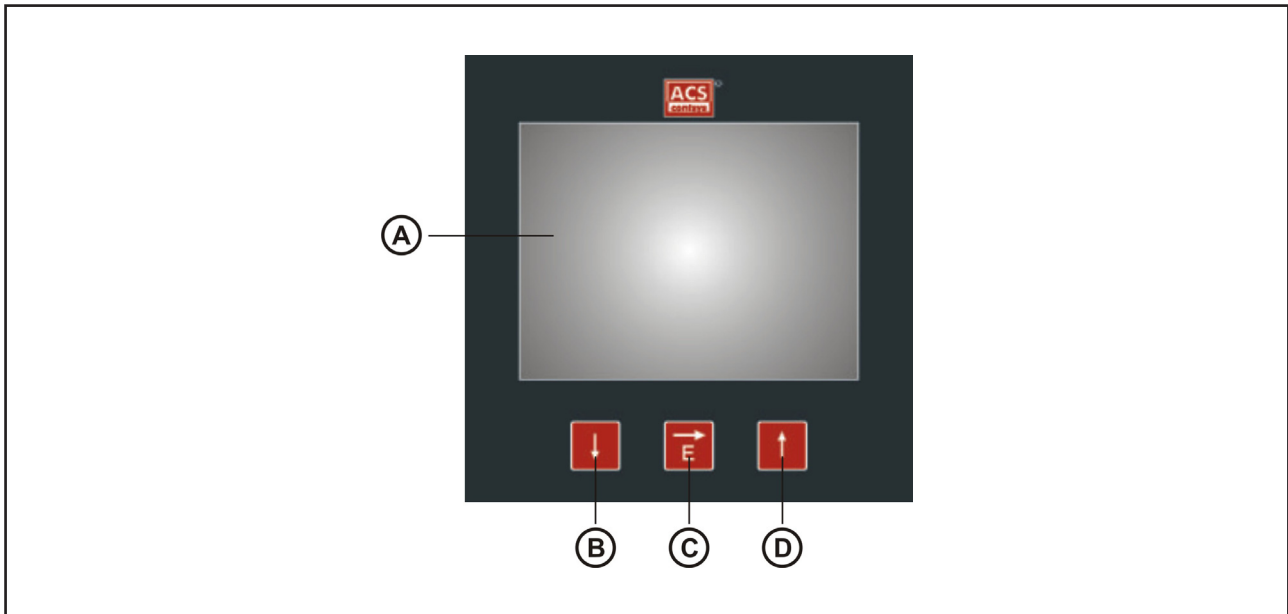

A - LCD display

- Display of measuring value, device state and operation menu

B - Key Down

- In the selection menu navigation downwards
- In the set menu decreasing of value
- Used, in combination with the key up, for leaving selection and set menu without applying changing's
- Used, in combination with the key up, for a step backwards one menu item

C - Key Enter/Shift right

- Access to operation menu
- In the selection menu entering the selected sub menu
- In the set menu applying the new value and digit shift right

D - Key Up

- In the selection menu navigation upwards
- In the set menu increasing of value
- Used, in combination with the key down, for leaving selection and set menu without applying changing's
- Used, in combination with the key down, for a step backwards one menu item

5.2 Function scheme

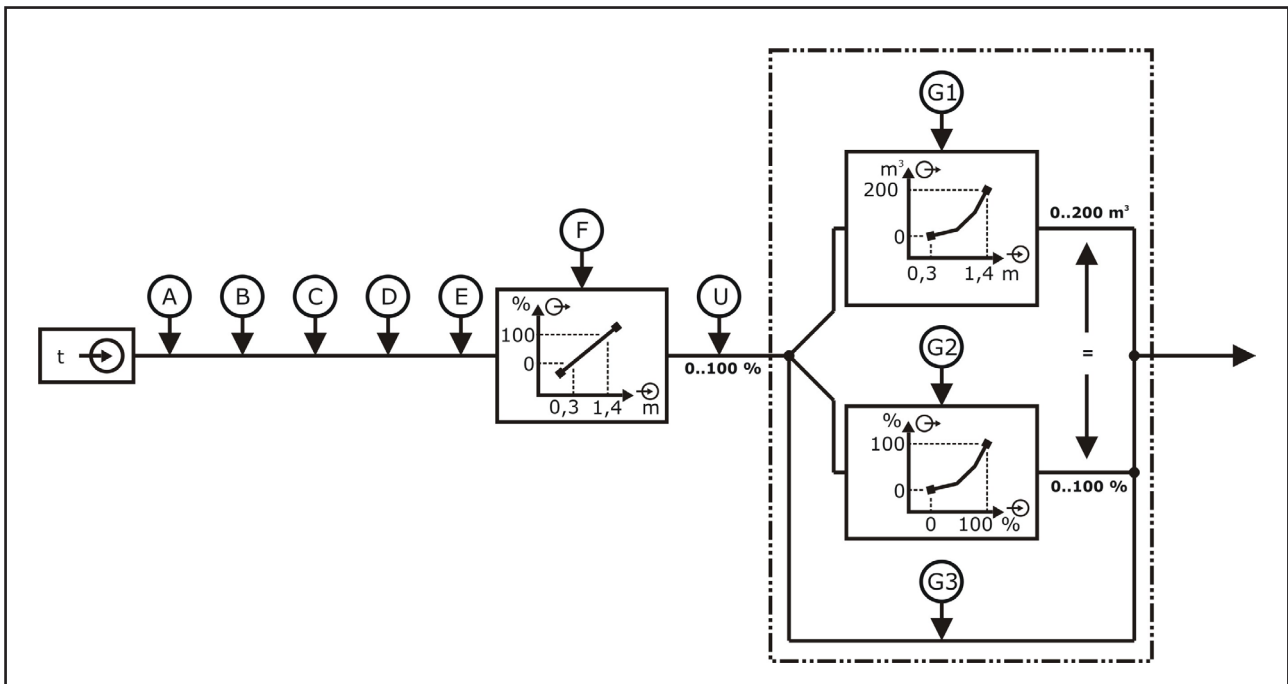

- A - Commissioning
- B - Operating mode (4..20mA/0..20mA/0..10V)
- C - Pulse rate
- D - Echo loss
- E - Damping
- F - Min/Max adjustment > e.g. 0,3..1,4m = 0..100%
- U - Limit min/max
- G1 - Linearization > level - display scaling e.g. 0,3..1,4mA = 0..200m³
- G2 - Linearization > percent 0..100% - lin. percent 0..100%
- G3 - No linearization

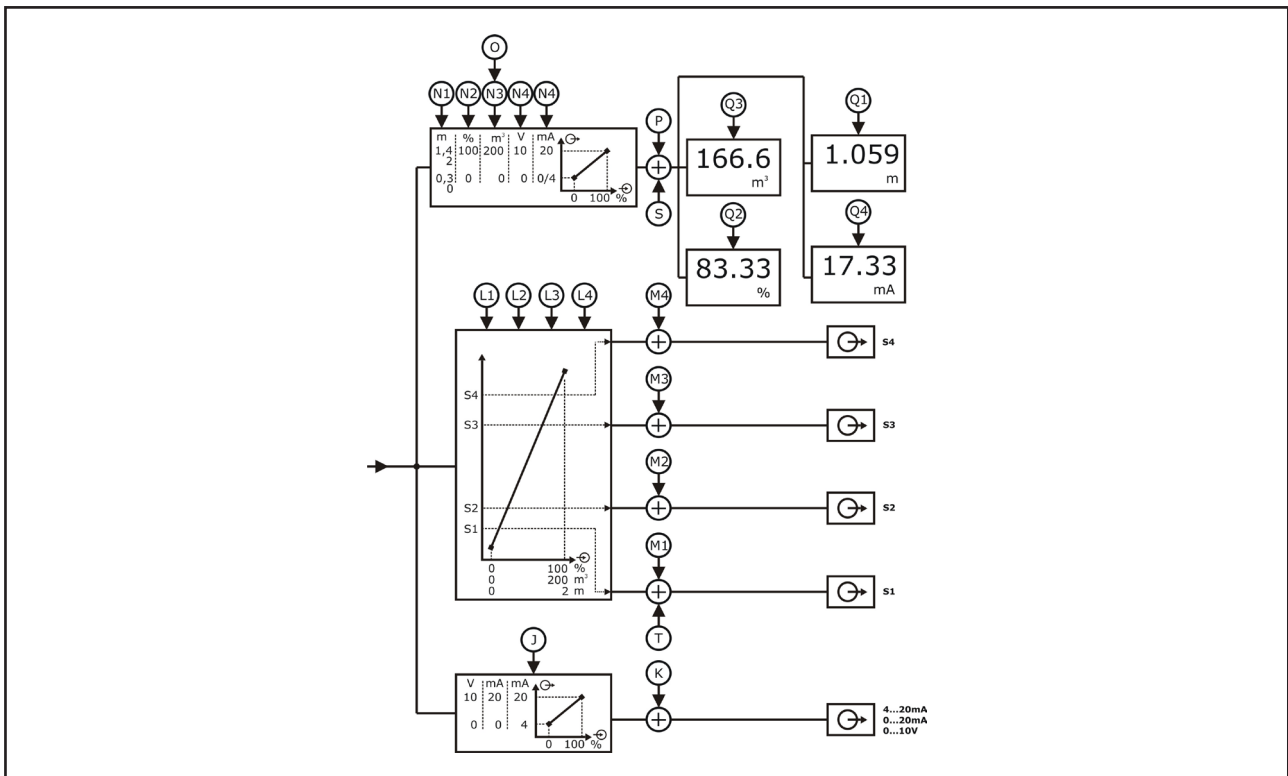

J - Analogue output > e.g. 0..100% = 4..20mA resp. 0..20mA resp. 0..10V

K - Error signal evaluation

L1 - Switch / reset switch point S1

L2 - Switch / reset switch point S2

L3 - Switch / reset switch point S3

L4 - Switch / reset switch point S4

M1 - Error indication function S1

M2 - Error indication function S2

M3 - Error indication function S3

M4 - Error indication function S4

N1 - Display scaling > Distance resp. level = 4..20mA resp. 0..20mA resp. 0..10V

N2 - Display scaling > Percent 0..100% = 0..100%

N3 - Display scaling > scaled e.g. 0..100% = 0..200

N4 - Display scaling > Analogue Output 0..100% = 4..20mA resp. 0..20mA resp. 0..10V

O - Display unit > at display scaling scaled e.g. m³

P - Error indication display

Q1 - Display - Distance 0...2m resp. level 0,3...1,4m

Q2 - Display - Percent 0..100%

Q3 - Display - scaled e.g. 0..200m³

Q4 - Display - Analogue Output 4..20mA resp. 0..20mA resp. 0..10V

R - Analogue output > Percent 0..100% - Lin. Percent 0..100%

S - Quantity counter > e.g. m³/h, l/min

T - Impulse output S1 for quantity counter

5.3 Menu structure

The entrance to the different function areas of the selection and set menu layer is done by the main menu (push the key Enter/Shift right for 3 seconds).

If failures are registered (see chapter diagnose/failure), these are indicated prior the jump into the main menu.

By the key Enter/Shift right the failure indication will be canceled.

The symbol E at a menu item indicates its position in the extended menu structure.

This extended menu structure can be shown in the submenu display by the menu item menu structure.

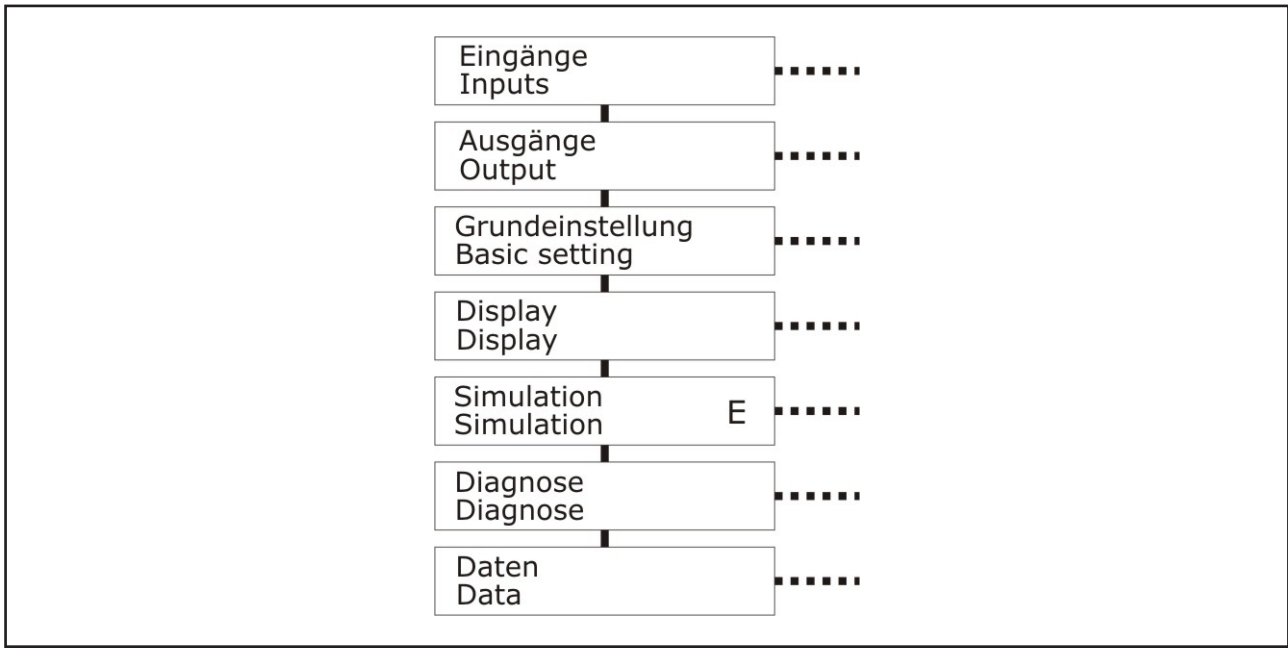

- *Submenu input*
Settings for the function of analogue input and digital inputs.
- *Submenu output*
Settings for the function of switch outputs and analogue output.
- *Submenu basic setting*
Settings for the basic adaption of the device to the measuring task, e.g. adjustment, damping and linearization.
- *Submenu display*
Settings for the adaption of the measuring value indication to the measuring task, e.g. measuring value scaling, display type, menu language and also password protection.
- *Submenu simulation*
Settings for the simulation of the switch outputs and the analogue output, e.g. for inauguration or also for failure analysis.
- *Submenu diagnose*
Multiple information to the historical measuring activity and the device, which can be useful for system surveillance or also for failure analysis.
- *Submenu data*
Settings for the measuring value recording and the data transmission by Bluetooth.

5.4 Navigation

The navigation in a submenu and in a selection window is done by the keys Up and Down.

The selection of a submenu and the selection of a setting in a selection menu is done by the key Enter/Shift right.

The jump backward from a submenu to the higher-level menu is done by the menu item back or by the simultaneous pushing the keys Up and Down.

The exit of a selection menu without applying the changing's is done by the simultaneous pushing the keys Up and Down.

The input of a value or text in a set menu is done digit by digit.

For the changing of the selected digit the keys Up and Down are used.

For the changing of the digit the key Enter/Shift right is used.

The applying of a set value resp. text is done by pushing the key Enter/Shift right for 3 seconds.

The exit of an set menu without applying a value resp. text is done by the simultaneous pushing the keys Up and Down.

After 5 minutes of inactivity the active submenu resp. selection menu will automatically be left and a change to the measuring value indication is executed.

A jump backward is not executed from an active set menu.

5.5 Input

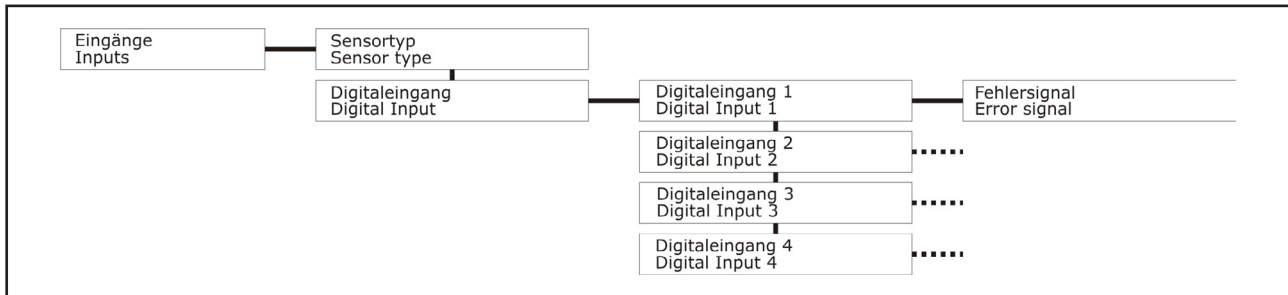

5.5.1 Sensor type – InA1

Defines the connected sensor.

- USG2 250
- USG2 150
- USG2 080
- USG2 050
- USG2 020

Default > preset according to sensor resp. USG2 020

5.5.2 Digital input – InD1...D4

5.5.2.1 Error signal

Defines the signal level, which is interpreted as error signal.

- Low
- High

Default > Low

5.6 Output

The symbol E at a menu item indicates its position in the extended menu structure. This extended menu structure can be shown in the submenu display by the menu item menu structure.

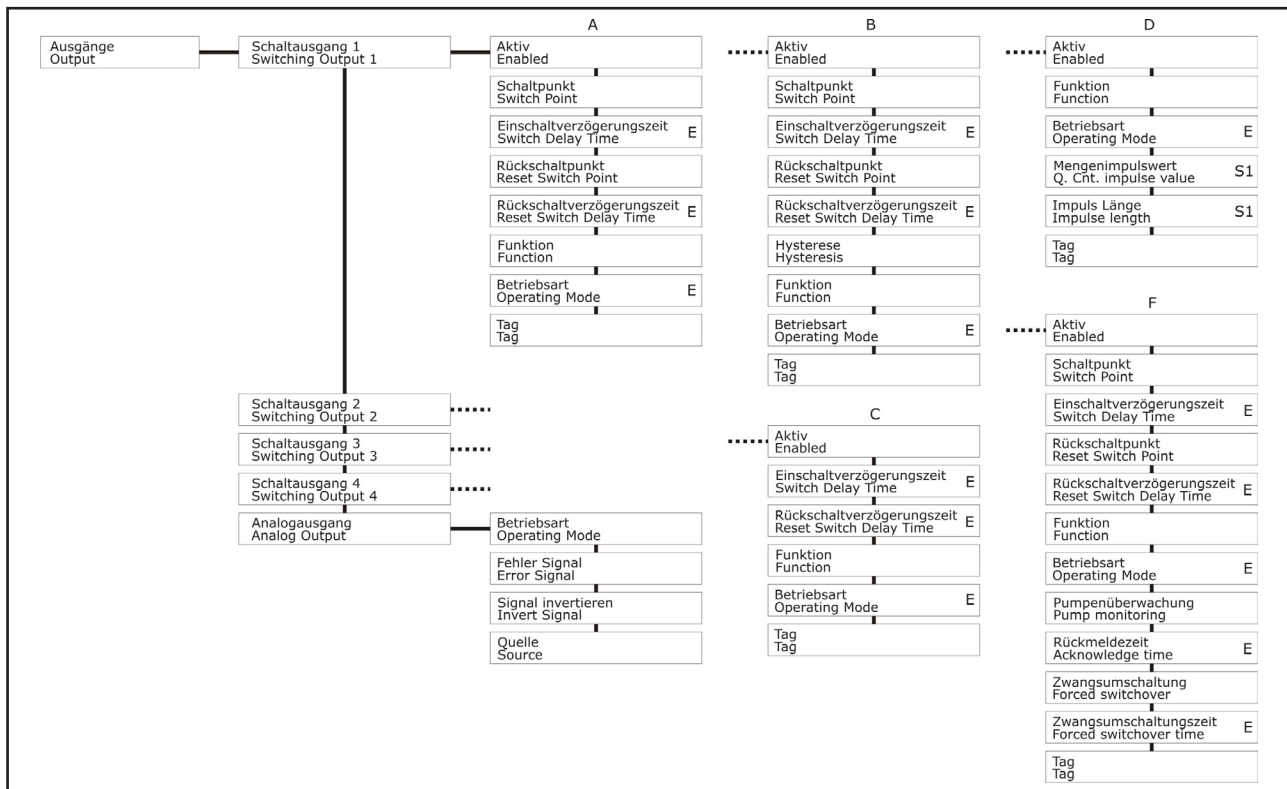

- A – Hysteresis function
- B – Window function
- C – Error indication function
- D – Impulse function
- F – Pump function

5.6.1 Switch output S1 / S2 / S3 / S4

5.6.1.1 Enabled

Each switch output can be activated resp. deactivated separately.

- Yes
- No

Default > Yes

5.6.1.2 Switch Point / Reset Switch Point

This menu item is not available at function principle error indication function resp. impulse function. The input values refer to the set display value or acc. to display scaling.

The current measuring value is indicated on the display.

The reset switch point must be lower or equal to the switch point.

The input range is limited to the measuring range.

Default > S1 = 20% / S2 = 40% / S3 = 60% / S4 = 80%

5.6.1.3 Switch / Reset Switch Delay Time – extended menu structure

This menu item is not available at function principle impulse function.

The activation resp. deactivation of the switch output can be biased with a delay time (resolution 0,01s), to realize simple sequence control system.

The input range is indefinite.

Default > 0s

5.6.1.4 Hysteresis

This menu item is only available at function principle window function.

The effects of this parameter are described in the chapter "Function – Window function".

The input range is indefinite.

Default > 0%

5.6.1.5 Function – extended menu structure

Selection of the function principle of the switch output.

- **Hysteresis function – S1...S4**

The hysteresis function realizes a stable switch state, independent from system conditioned signal fluctuations around the adjusted set point.

It can be used for realizing a signal controlled two-position control.

The switch range is determined by definition of switch point and reset switch point.

The behavior can be selected in the menu "Operating Mode".

In the menu Operating Mode, the working principle of the switch output can be inverted.

- **Operating Mode Maximum**

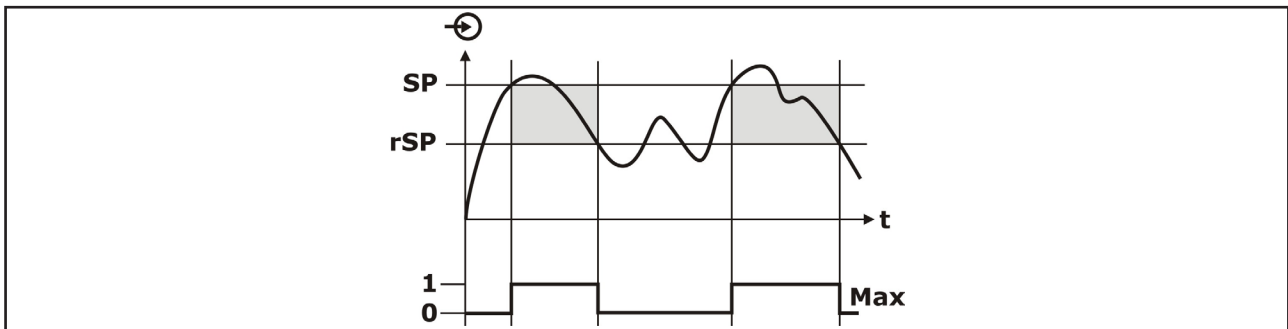

The switch output is activated, if the current measuring value overshoots the switch point and if the set switch point delay time has been expired.

The switch output is deactivated, if the current measuring value undershoots the reset switch point and if the set reset switch point delay time has been expired.

- **Operating Mode Minimum**

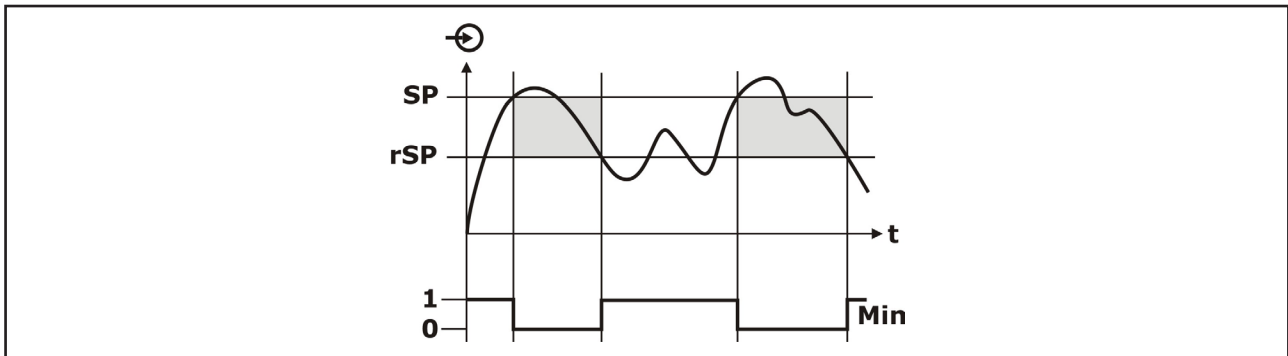

The switch output is activated, if the current measuring value undershoots the reset switch point and if the set reset switch point delay time has been expired.

The switch output is deactivated, if the current measuring value overshoots the switch point and if the set switch point delay time has been expired.

- **Window function – S1...S4**

The window function realizes a signal range – acceptance region –, where the switch output is set to a definitive switch state.

The switch range is determined by definition of switch point, reset switch point and hysteresis.

In the menu Operating Mode, the working principle of the switch output can be inverted.

- **Operating Mode outside**

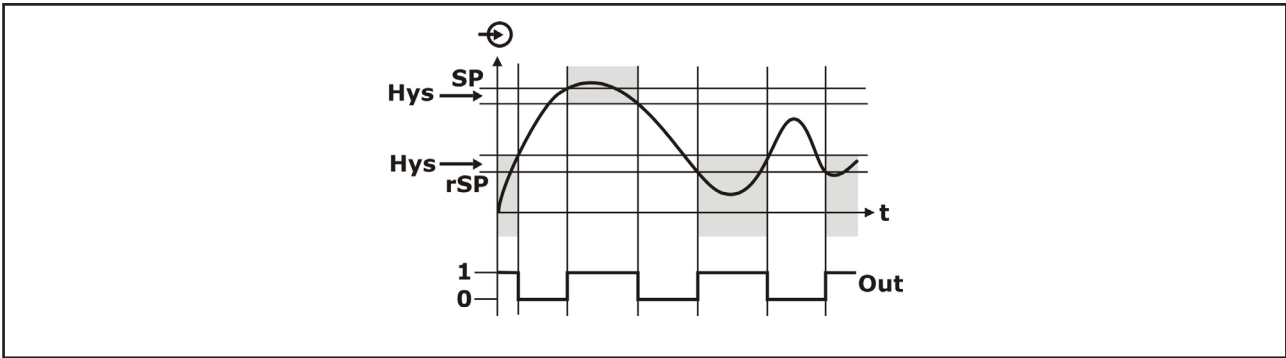

The switch output is activated, if the current measuring value is outside the area that is defined by the switch point and the reset switch point and if the set switch point delay time has been expired.

The switch output is deactivated, if the current measuring value is inside the area that is defined by the switch point and the reset switch point and if the set reset switch point delay time has been expired.

The hysteresis is positioned inside the area that is defined by the switch point and the reset switch point.

- **Operating Mode inside**

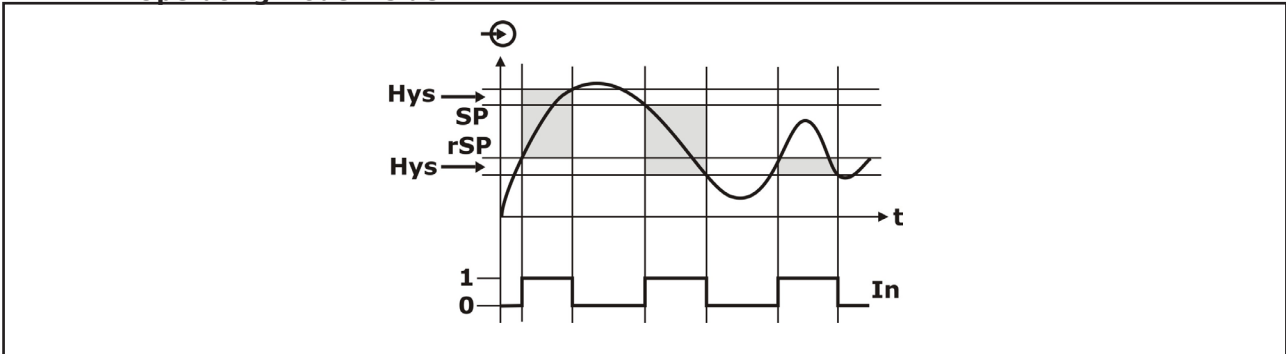

The switch output is activated, if the current measuring value is inside the area that is defined by the switch point and the reset switch point and if the set switch point delay time has been expired.

The switch output is deactivated, if the current measuring value is outside the area that is defined by the switch point and the reset switch point and if the set reset switch point delay time has been expired.

The hysteresis is positioned outside the area that is defined by the switch point and the reset switch point.

- **Error Indication Function – S1...S4**

The switch output is activated, if the device has detected a failure behavior (see chapter diagnose/failures).

In the menu Operating Mode, the working principle of the switch output can be inverted.

- **Impulse Function – S1**

The switch output generates one switch impulse per calculated quantity value of the quantity counter (see data/quantity counter).

A warning message is generated, if the quantity counter impulse value is set too low or the impulse length is set too high. The calculation base for this warning message is the display scaling at 100%.

- Quantity counter impulse value
Amount of the quantity counter value, for which one switch impulse is generated.
The input range is indefinite.
Default > 1
- Impulse length
Duration of a pulse resp. additionally the duration of a pulse pause.
The input range is limited to values from 0,1 to 99999.
Default > 0,5s

In the menu Operating Mode, the working principle of the switch output can be inverted.

- **Pump function runtime – S1...S4**

Pump function runtime is used to control several pumps with the same function dependent on the previous running time.

Always the pump with the shortest running time is switched on and the pump with the longest running time switched off.

With increased requirement, all pumps can also run at the same time dependent on the entered switching points. With this measure, a steady utilization of the pumps is achieved and the reliability increased.

All switch outputs with activated pump control are not assigned to a certain switching point but are switched on or of depending on the accumulated operating time. The signal conditioning instrument selects the switch output with the shortest operating time when the switch point is reached and the relay with the longest operating time when the reset switch point is reached.

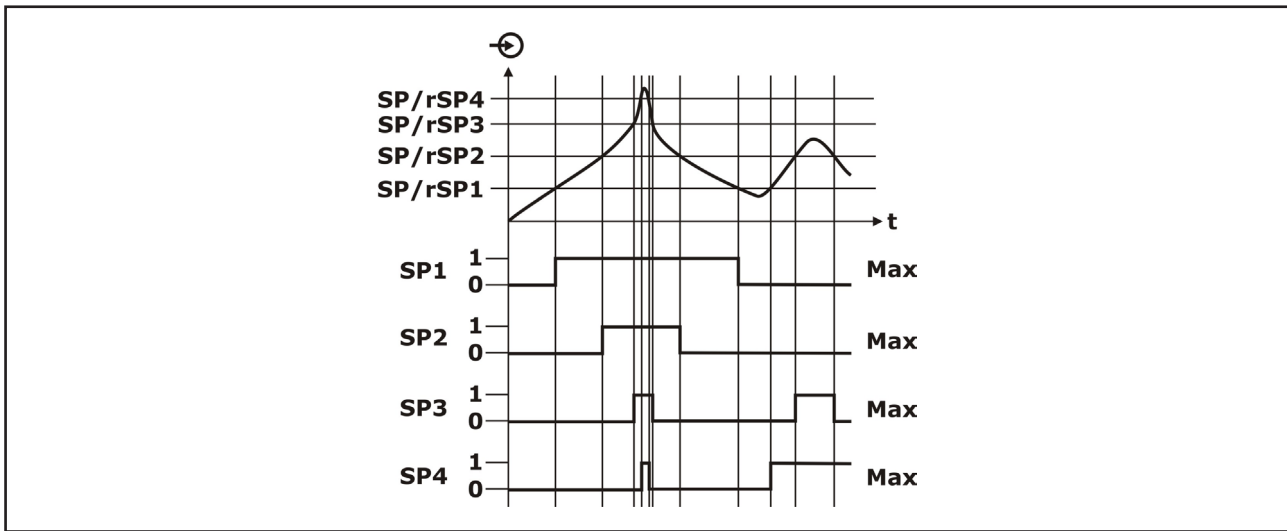

Switch point and reset switch point can be set to different values, to achieve a complex switch mechanism.

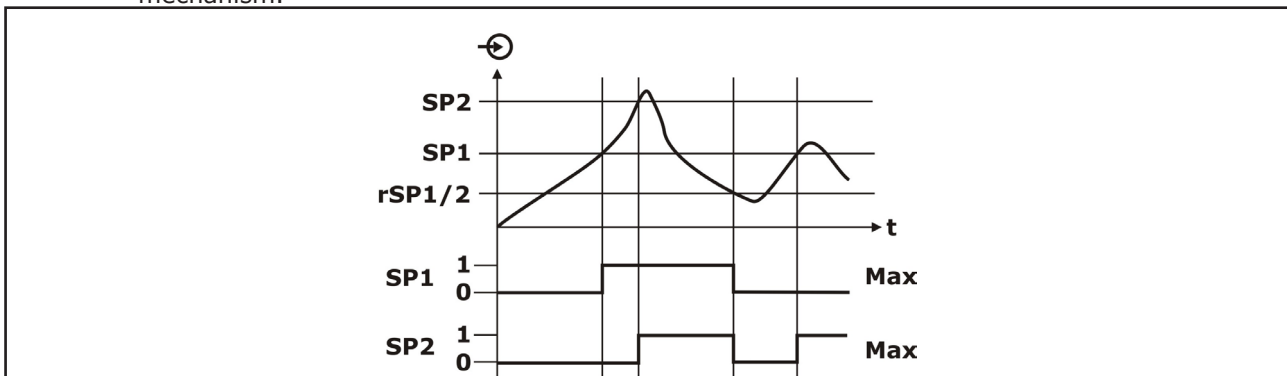

The runtime of each switch output can be reset in the menu „Diagnosis – Switching output“. In the menu Operating Mode, the working principle of the switch output can be inverted. A pump monitoring can be activated. The effects of this parameter are described in the chapter „Pump monitoring“.

- **Pump function sequential – S1...S4**

Purpose of the pump function sequential is the alternating use of multiple pumps for the same task (Overflow protection or dry running protection).

Due using the pumps for the same task, it can be detected by the pump switch-on time, if one of the pumps doesn't operate with the necessary performance (Runtime of the pump increases).

All switch outputs, which are activated for pump function, are not assigned to a certain switch point, but should be switched-on resp. switched-off alternating. When reaching the switch delay value, the evaluation device chooses the switch output, which is next in the alternating row.

When reaching the reset switch point, the switch outputs are switched-off in the same order like they have been switched-on.

The order is predefined. It starts with the switch output with the lowest index. The next switch output is the switch output with the next higher index. After the switch output with the highest index it will be changed to the switch output with the lowest index, e.g. S1...S2...S3...S4...S1...S2....

The order is valid for all switch outputs, which corresponds to the pump function.

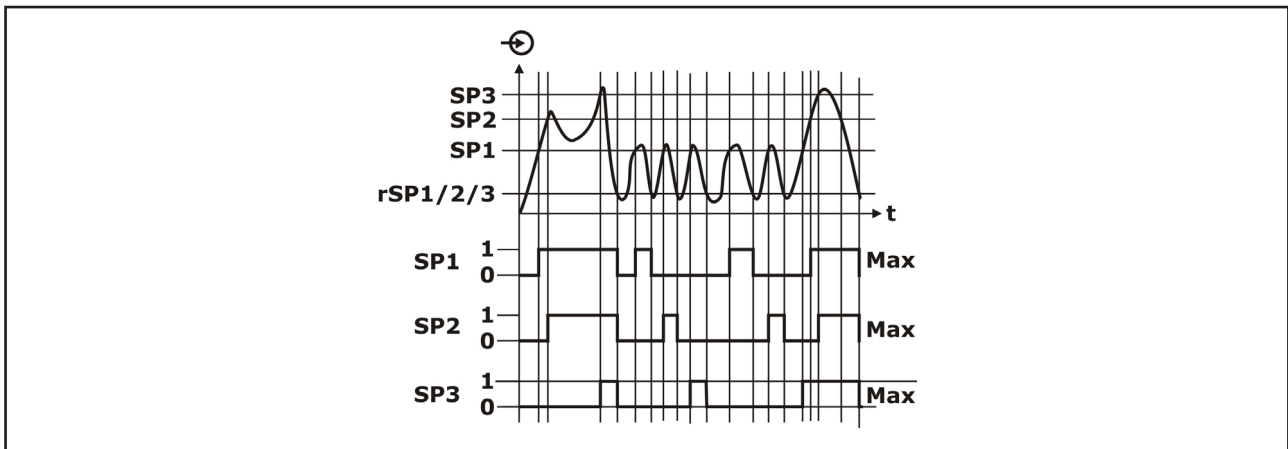

A pump monitoring can be activated. The effects of this parameter are described in the chapter „Pump monitoring“.

The index of the last switched-on switch output will not be saved, that means that after power-on it will be started always with the switch output with the lowest index.

In the case, that multiple pumps are operated alternating in the same range, the switch points resp. reset switch points must be set to the same value.

Due to this, all switch outputs will switch always together. To achieve still the required switch behaviour, one switch output must be set to the needed switch point resp. reset switch point. All other switch outputs must be set to switch points resp. reset switch points, that will never be achieved in standard operation.

In the menu Operating Mode, the working principle of the switch output can be inverted.

Default > Hysteresis Function

5.6.1.6 Operating Mode

The operating mode defines the function direction of the switch output, dependent on the function. The effects of this parameter are described in the respective sub-chapter of the chapter „Function“.

5.6.1.7 Pump monitoring

This menu item is only available at function principle pump function runtime resp. pump function sequential.

For the pump monitoring a feedback signal at the respective digital input is necessary.

The assignment of the digital inputs to the switch output is predefined fixed.

- Digital input 1 – switch output 1
- Digital input 2 – switch output 2
- Digital input 3 – switch output 3
- Digital input 4 – switch output 4

If the pump monitoring for a switch output is activated, a timer, that must be set to the required value at the menu "Acknowledge time", starts running when switch-on the switch output.

The menu „Acknowledge time“ is only available at activated pump monitoring.

If the pump feedback of the pump at the corresponding digital input is detected within the defined acknowledge time, the pump switch output stays on. Otherwise the switch output is switched-off immediately and an error signal is output.

An error signal and the switch-off of the switch output is also processed, if the switch output is already switched-on and the pump feedback signal changes within the runtime of the pump.

Additionally a switched-off switch output of the pump function is searched and switched-on instead of the faulty switch output of the pump function.

The level at the digital input, a low or a high-signal, which is evaluated as error signal of the pump, can be set in the menu "Inputs – Digital Inputs 1...4".

To delete the error signal, the signal at the digital input must change to "good".

- Yes
- No

Default > No

5.6.1.8 Acknowledge time

This menu is only available at activated pump monitoring.

The effects of this parameter are described in the chapter "Pump monitoring".

The input range is indefinite.

Default > 0s

5.6.1.9 Forced switchover

This menu item is only available at function principle pump function runtime resp. pump function sequential.

The purpose of the forced switchover is the change of a pump after a predefined time.

This gets relevant, if the measuring value does not change for a longer time and thus always the same pump is switched-on.

The parameter forced switchover time defines the time, after that a forced switchover of the pump is processed.

The menu „Forced switchover time“ is only available at activated forced switchover.

The pump, which is switched-on, depends on the chosen pump function. If already all pumps of the pump function are switched-on, the pump stays switched-on.

If the pump is already switched-on, when the forced switchover is activated, the timer will not be started. The timer starts after the next switch-off and a new switch-on.

At the forced pump switchover, a set reset switch delay time will not be considered, that means the forced switchover is processed exactly after the set forced switchover time.

At the forced pump switchover, a set switch delay time will be considered, that means the forced switchover to another pump is processed exactly after the time.

The set switch delay time for this pump must be expired, before the new selected pump will be switched-on.

- Yes
- No

Default > No

5.6.1.10 Forced switchover time

This menu is only available at activated forced switchover.
The effects of this parameter are described in the chapter "Forced switchover".
The input range is indefinite.

Default > 1h

5.6.1.11 TAG

Due to the TAG the different switch outputs can be named individually. At the indicator type digital the TAG is indicated in the display.
Up to 10 characters can be input.
The input range is indefinite.

Default > no TAG allocated

5.6.2 Analogue output – OutA1

The nominal values of the analogue output signal (4/20mA resp. 0/10mA resp. 0/10V) refers to the set display nominal values 0% and 100%

5.6.2.1 Operating Mode

Defines the type of the analogue output signal

- 4-20mA
- 0-20mA
- 0-10V

Default > 4-20mA

5.6.2.2 Error Signal

Defines, dependent on the operating mode, the analogue output signal regarding operating range and if errors (see chapter diagnose/failures) are registered.

- Operating mode 4-20mA

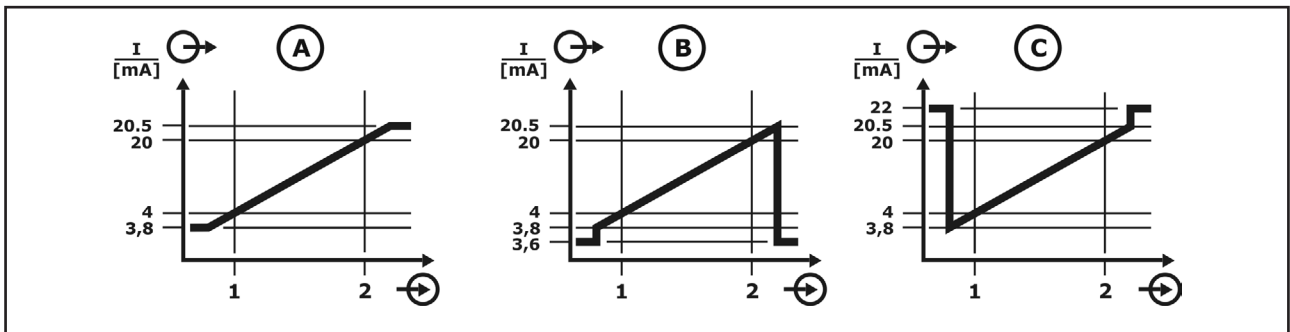

- A - Off >> 3.8-20,5mA
- B - 3.6mA
- C - 22mA

- Operating mode 0-20mA

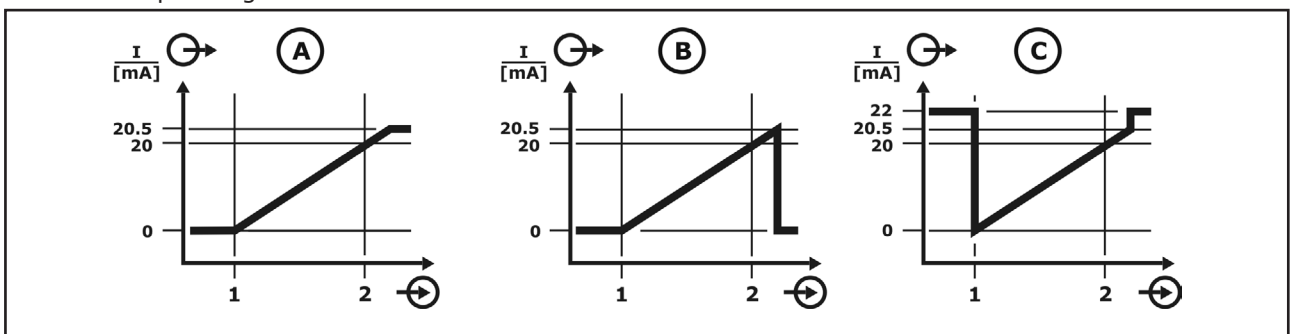

- A - Off >> 0-20,5mA
- B - 0mA
- C - 22mA

- Operating mode 0-10V

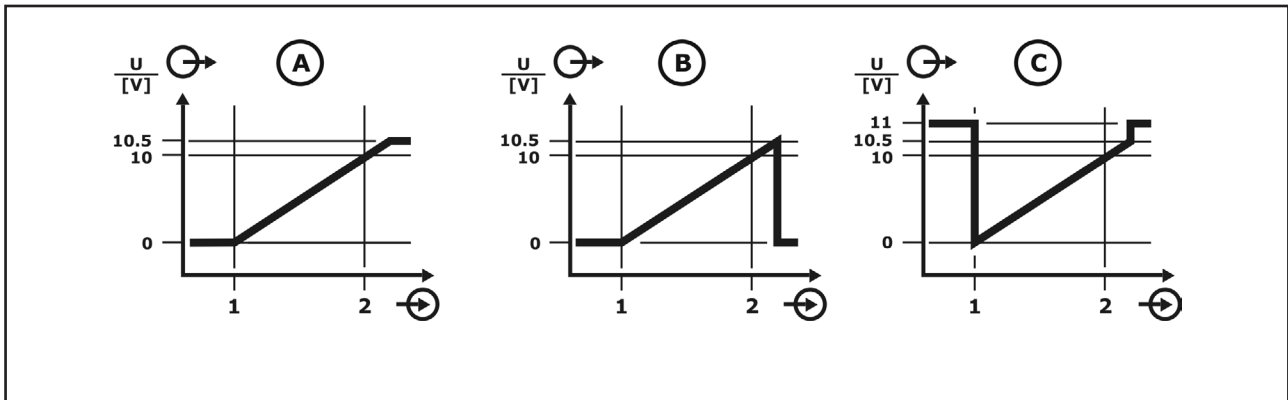

- A - Off >> 0-10,5V
- B - 0V
- C - 11V

Default > Off

5.6.2.3 Invert Signal

Inverts the analogue output signal dependent on the operating mode.

- 4-20mA >> 20-4mA
- 0-20mA >> 20-0mA
- 0-10V >> 10-0V

Default > No

5.6.2.4 Source

Defines the source for the generation of the analogue output. For the source, it can be chosen between the measuring value before (%) or after (Lin %) an optionally set linearization.

This allows e.g. the output of a linear filling level at the analogue output, whereas a linearized volume is shown at the display.

- Lin %
- %

Default > Lin %

5.7 Basic Setting

The symbol E at a menu item indicates its position in the extended menu structure. This extended menu structure can be shown in the submenu display by the menu item menu structure.

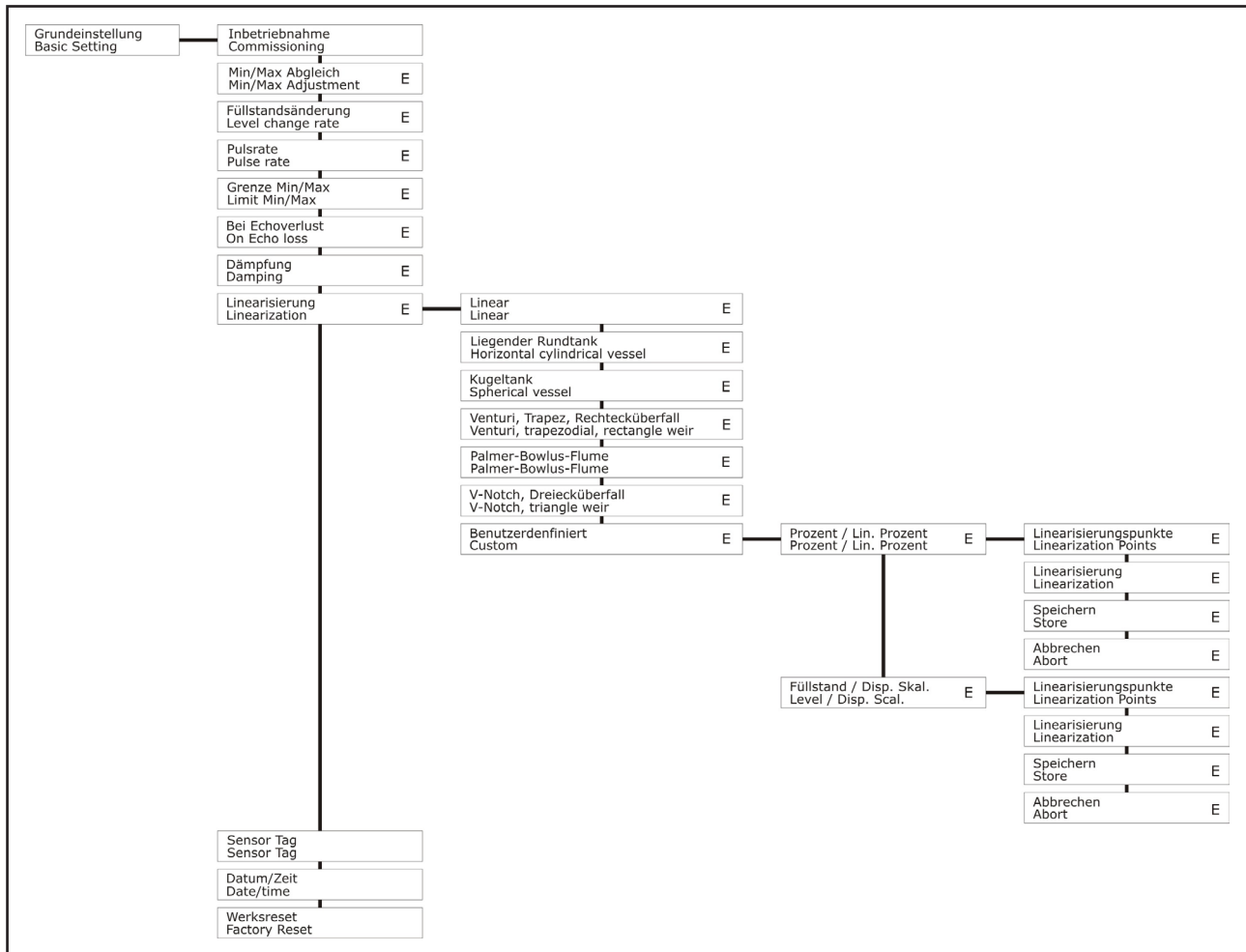

5.7.1 Commissioning

The commissioning function can be used to adapt the device to the constructive conditions. Therefore the device must be operated in its finally installed position at the maximum possible distance resp. at the lowest possible known filling level. The detected measuring value must be confirmed or possibly corrected. Afterwards the detection of the envelope curve for the error echo suppression is processed. Error echoes causing installations, positioned below the filling level when processing the commissioning function, cannot be detected.

5.7.2 Min/Max-Adjustment

The min/max-adjustment set the measuring range limits. 2 points are defined, that set the ratio of the measured pressure/level and the measuring range of the device. The current measuring value is indicated in the display. The input of the measuring range limits 0% and 100% are not mandatory. Values within the measuring range e.g. 11% and 87% can be also input. In this case there is an automatic calculation to 0% resp. 100%. The higher the difference between these points, the more precise is the following calculation. The min/max-adjustment is relevant for linearization, analogue output and display scaling.

- Lower adjustment value
- Upper adjustment value

The input range is indefinite.

Default > Lower calibrated measuring value = 0% / Upper calibrated measuring value = 100%

5.7.3 Level change rate

The measured signal can be checked for plausibility, to blank out abrupt signal changes e.g. due to an agitator. The maximum signal change rate, that can occur e.g. at filling or emptying, must be set. Faster signal changes will then be blanked out.

- Jumpy – no plausibility check
- Less than 1m/s
- Less than 0,5m/s

Default > Jumpy

5.7.4 Pulse rate

The pulse rate defines the measurement velocity resp. the repetition rate of the ultrasonic measurement pulses.

The use of a slower pulse rate (tp) can be used for energy saving and also for conservation of the sensor (reduction of component stress due to high energetic ultrasonic signals).

The use of a slower pulse rate extends the actualization time of display and outputs by the respective factor.

- very fast – maximum pulse rate (see chapter „Technical Data“) x factor 1
- fast – maximum pulse rate (see chapter „Technical Data“) x factor 0,5
- slow – maximum pulse rate (see chapter „Technical Data“) x factor 0,25

Default > very fast

5.7.5 Echo loss

If no measuring signal can be detected, e.g. due to a too high distance or a strong deviation of the ultrasonic signal, up to the next valid measuring signal alternatively the last detected measuring value can be hold or the minimum resp. maximum adjusted limit value can be output.

- hold
- maximum measuring range
- minimum measuring range

Default > hold

5.7.6 Limit min/max

If the measuring value exceeds the limits of the Min/Max-Adjustment, these limits are kept at activated function. An exceedance is not possible.

At deactive function measurement values besides the limit values are output.

- deactive
- active

Default > deactive

5.7.7 Damping

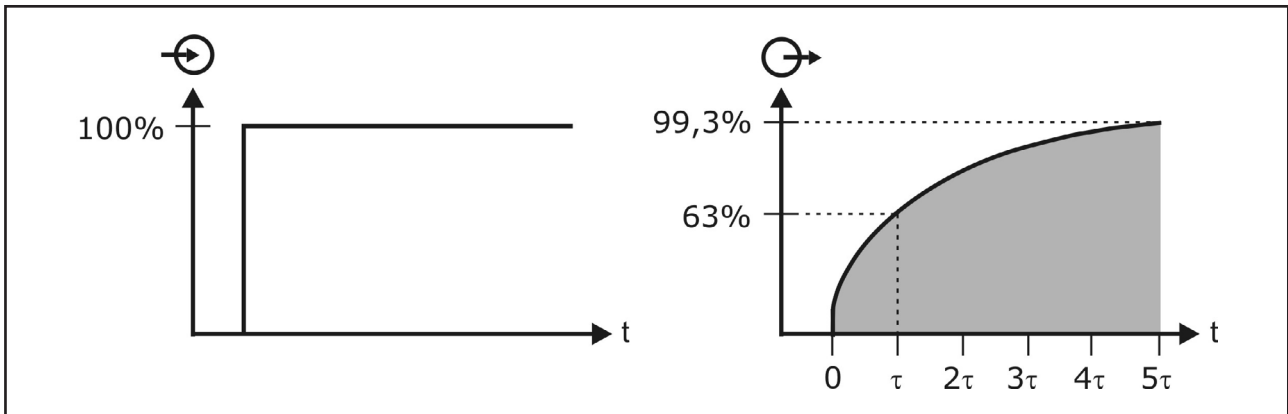

The damping influences the reaction speed of display, output signal and switch output at a change of the measuring signal.

The behavior of display and output signal follows an exponential characteristic with the damping time constant t .

Within the time period t the output signal increases respectively by 63% of the existing deviation. With 99,3%, the end value is nearly achieved after $5t$.

The input range is indefinite.

Default > 1 sec

5.7.8 Linearization – extended menu structure

Due to the integrated linearization function it is possible, to linearize a measuring signal e.g. for volume calculation of conical or horizontal cylindrical vessels or also for flow calculation.

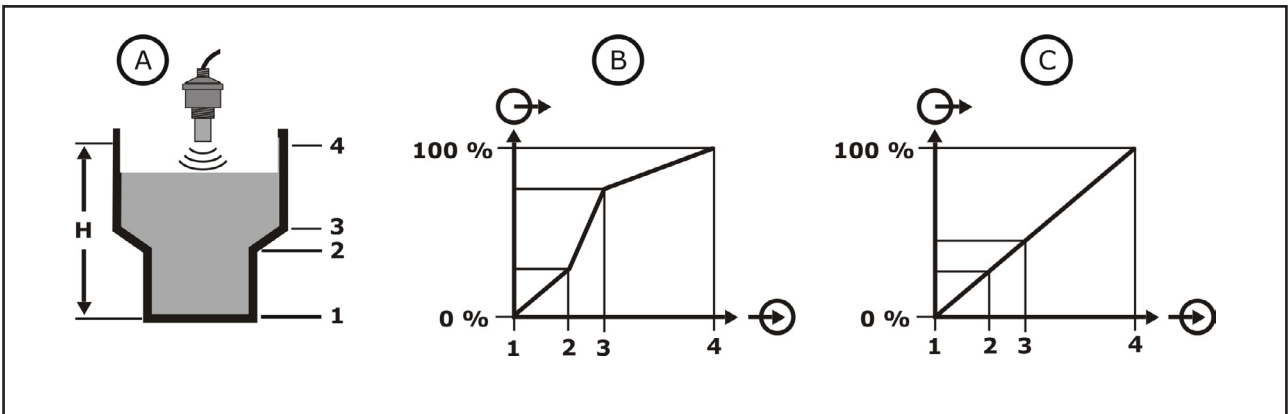

A - Tank with linearization points 1 / 2 / 3 / 4

B - Characteristic distance - level not linearized

C - Characteristic distance - level linearized

5.7.8.1 Predefined linearization curves

- Linear - no linearization
- **Volume linearization**
 - Horizontal cylindrical vessel
 - Spherical vessel
- **Flow linearization**
 - Venturi, trapezoidal weir, rectangle weir
 - Palmer-Bowlus-Flume
 - V-Notch, triangle weir

-
- **Free linearization characteristic with up to 40 points**

- Custom

Default > Linear

5.7.8.2 Input mode custom defined linearization

- Percent / Linearized Percent
- Level / Display Scaling

The percentual input (referring to the measuring range) is only possible without applying measuring value - dry adjustment -, whereby the input in level and display scaling e.g. liter can be done without applying measuring signal - dry adjustment - as well as with applying measuring signal – wet adjustment -.

At the linearization without applying measuring signal, for each linearization point a needed signal value (in percent or level) is input and referred to the needed output value (in percent or primary unit) that must be also input.

At the linearization with applying measuring signal, for each linearization point the current measuring value is captured and referred to the output value (acc. to display scaling) that must be input.

- **Linearization Points**

The number of linearization points for the complete measuring characteristic must be defined. The input range is limited to values from 2 to 40.

Default > 2

- **Linearization**

At the input mode percent / linearized percent the input signal refers percentual to the measuring range, that is defined at the min./max. adjustment for 0% and 100%. The output signal must also be considered percentual.

At the input mode level / display scaling the input signal refers to the input signal with unit m. The output signal refers to the display range (level or scaled), that is defined in the display scaling.

The complete characteristic, eventually also the measuring range end values 0% and 100% must be defined, cause the measuring range end values from the min./max. adjustment are not copied into the linearization table.

The input range is indefinite.

Default > Linearization point 1 > 0.000% = 0.000% resp. 0.000m / Linearization point 2 > 100.000% = 100.000% resp. 8.000m

- **Store**

Input linearization points are not automatically stored loss-protected.

To store one or also more linearization points loss-protected, the function store must be executed.

5.7.9 Sensor TAG

Due to the Sensor TAG different devices can be differentiated. At the indicator type digital the Sensor TAG is indicated in the display.

The Sensor TAG is added automatically to the Bluetooth-name, to allow the device identification when using multiple devices in reception range.

Up to 19 characters can be input.

The input range is indefinite.

Default > no Sensor TAG allocated

5.7.10 Date/Time

Input of date and time. For the measurement value recording, the measurement values are supplied with a time stamp of the integrated real time clock, which includes date and time. The set values are buffered at a short time (see chapter „Technical data“) supply voltage fail, whereas a longer failure resets the values. The values must then be set again.

At the battery powered system the values are buffered also at a long term failure of the supply voltage.

The input range is limited to conclusive values for date and time.

Default > 01.01.2001 / 00:00:00 resp. current date / current time

5.7.11 Factory Reset

The factory reset changes all settings to default values.

The factory reset does not concern:

- Diagnose data
- Historical measuring data
- Storage interval
- Custom defined linearization

5.8 Display

The symbol E at a menu item indicates its position in the extended menu structure.

This extended menu structure can be shown in the submenu display by the menu item menu structure.

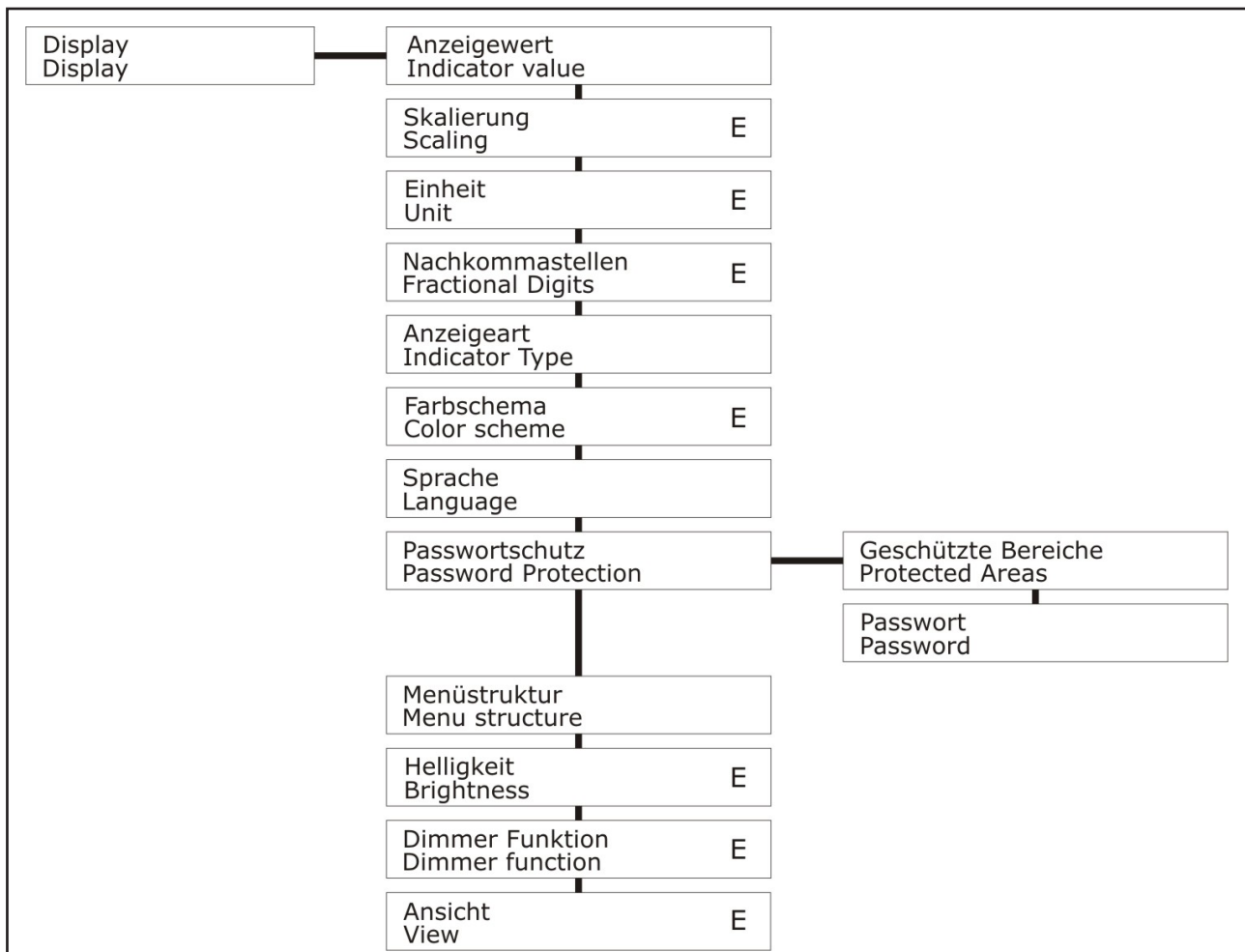

5.8.1 Indicator value – extended menu structure

The measuring value can be alternatively displayed as distance, as filling level, percentual, with any desired scaling referring percentual to the measuring range or by displaying the analogue output value.

- Distance
- Level
- Percent
- Scaled
- Analogue output

Default > Distance

5.8.2 Scaling – extended menu structure

This menu item is only available at indicator value scaled.

By defining a scaling the measuring range can be rescaled into any desired numerical range. This allows e.g. the indication of the volume in liter.

The current measuring value with up to 7 digit is indicated in the display.

The input of the measuring range limits 0% and 100% are not mandatory. Values within the measuring range e.g. 11% and 87% can be also input. In this case there is an automatic calculation to 0% resp. 100%.

- Lower display value
- Upper display value

The input range is indefinite.

Default > Measuring value 0.000% = Display 0.000 / Measuring value 100.000% = Display 100.000

5.8.3 Unit – extended menu structure

This menu item is only available at indicator value scaled

If a scaled indicator value is used, additionally an unit can be selected, that is indicated in the display (not at indicator type vertical bargraph).

The unit is only indicated as text and is not included into calculations.

There are multiple predefined units in different categories available. Alternatively a custom defined unit can be also input.

- Mass
- Volume
- Height
- Pressure
- Temperature
- Flow
- Custom defined

Up to 10 characters can be input.

The input range is indefinite.

Default > no text allocated

5.8.4 Fractional Digits – extended menu structure

The measuring value can be formatted by the use of fractional digits.

Is the indication of the measuring value with the current fractional digits number not possible, a change to the correct fractional digits number is executed automatically.

The input range is limited to values from 0 to 3.

Default > 3

5.8.5 Indicator Type

Dependent on the requirements the measuring values can be indicated in different types.

- **Digital**



Switch points, active or deactive

Sensor TAG

Digital measuring value

Unit

Quantity counter value (only at activated function quantity counter)

Horizontal scaled bargraph

Mark of switch points at the bargraph

- **Manometer**



Round pointer scale

Mark of the switch points at the pointer scale

Unit

Digital measuring value

- **Bargraph**



Digital measuring value

Unit

Horizontal scaled bargraph

- **Vertical Bargraph**

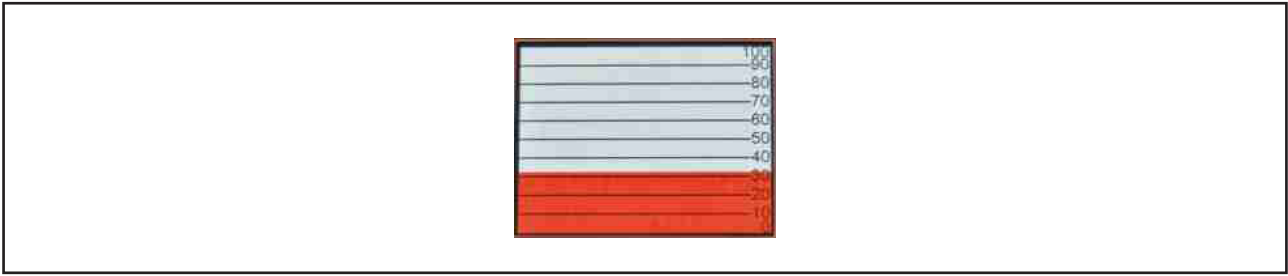

Vertical percentual scaled bargraph

- **Chart**



Scaled graphical measuring value-to-time-window

Selected historical digital measuring value with unit and with date / time

Digital measuring value with unit.

The entrance to the chart menu is done by pushing the key Enter/Shift right for 3 seconds.

The measuring value cursor can be set to the oldest resp. youngest measuring value or to an arbitrary point of time in days/hours/minutes/seconds.

Navigation of the measuring value cursor with cursor keys within the graphic window.

After 5 minutes of inactivity the measuring value cursor is automatically set to 0s

Default > Digital

5.8.6 Color Scheme – extended menu structure

For the adaption of the display to the requirements 6 color schemes are available.

- Standard / Black / Blue / Red / Green / Yellow

Color scheme black



Default > Standard

5.8.7 Language

The menu navigation can be done in the following different languages.

- Deutsch
- English

Default > Deutsch

5.8.8 Password Protection

For the protection of the settings against unauthorized persons individual or all main menu items can be protected by a password.

At each activation of the main menu the password protection is active.

An unknown or forgotten password can be erased by use of a service code and an activation code.

These codes can be requested at the manufacturer.

- **Protected Areas**

- Inputs
- Output
- Basic Setting
- Display
- Simulation
- Diagnose
- Data

Default > all No

- **Password**

Up to 10 characters can be input.

The input range is indefinite.

Default > no Password allocated

5.8.9 Menu Structure

For a breakdown illustration of the menu navigation different menu items (**mark E in the menu structures overview**) are arranged in a removable extended structure.

To achieve access to all functions of the device, the extended menu structure must be activated.

- Normal
- Extended

Default > Normal

5.8.10 Brightness – extended menu structure

For the adaption of the display to the requirements the brightness of the backlight can be varied in a wide range.

For the protection of the backlight at higher environmental temperatures, a reduction of the brightness can be necessary.

At an input value of 0 a minimum residual brightness is already present.

The input range is limited to values from 0 to 100.

Default > 75

5.8.11 Dimmer Function – extended menu structure

To reduce the supply current and also to minimize the system typical aging influences on the brightness of the backlight an automatic dim after 5 minutes of inactivity (no key touch) can be activated.

- 0% / 10% / 20% / 30% / 40% / 50% / Off

Default > 10%

5.8.12 View – extended menu structure

For the adaption of the display to the requirements of the installation situation the view of the display can be rotated by 180°.

- Normal
- 180°

Default > Normal

5.9 Simulation – extended menu structure

The symbol E at a menu item indicates its position in the extended menu structure. This extended menu structure can be shown in the submenu display by the menu item menu structure.

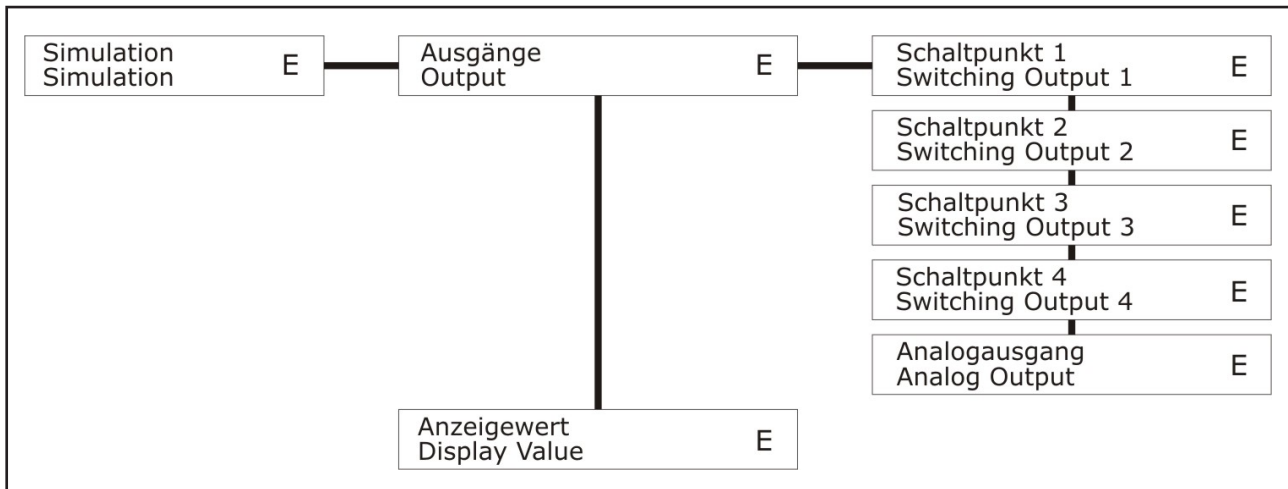

5.9.1 Output

5.9.1.1 Switch Output – S1...S4

The switch output is activated resp. deactivated regardless of an already existing activation and also regardless of delay times.

5.9.1.2 Analogue output – OutA1

At the analogue output a signal is output regardless of the current measuring value. The input range is limited, dependent on the set Operating Mode.

- 3.600 – 22.00mA (4-20mA)
- 0.000 – 22.00mA (0-20mA)
- 0.000 – 11.00V (0-10V)

5.9.2 Display Value

The display value can be simulated, whereby all following functional steps (analogue output, switch output) are also simulated acc. to the settings.

The input range is limited to the set measuring range.

5.10 Diagnose

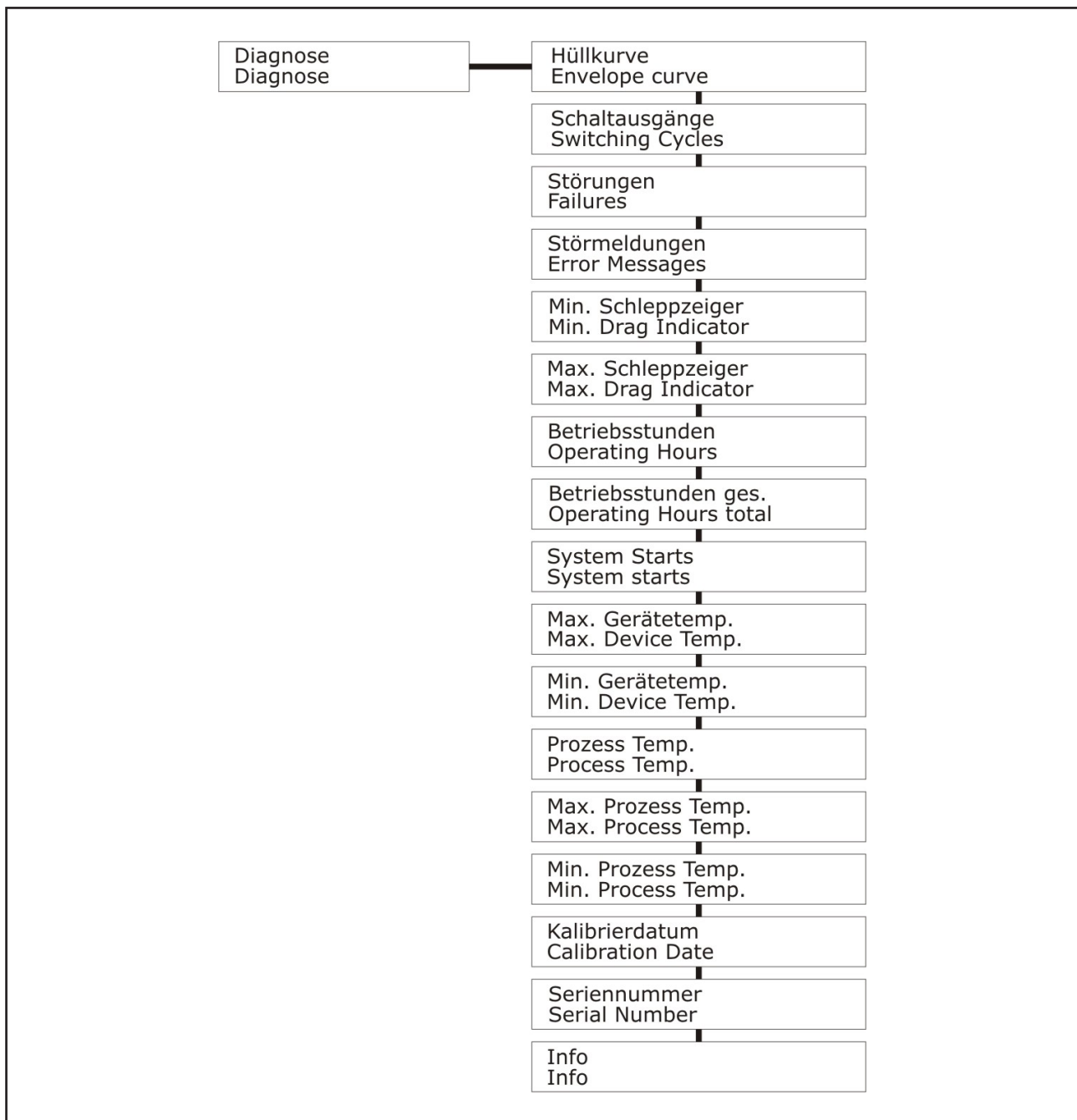

5.10.1 Envelope curve

The current measuring signal is displayed as curve.

The envelope curve is displayed, below those the measuring signal is ignored.

The valid measuring signal is marked by a vertical mark.

Downright the characteristic curve the current distance value is displayed with unit m and the corresponding measured signal level in dB.

- **Cursor resp. Zoom mode**

Below and left of the characteristic curve the position of a shiftable cursor is indicated.

A simple left-right-arrow-symbol allows a shift of the cursor by the keys Up resp. Down.

By simultaneous pushing of the keys Up and Down it is switched to the zoom mode for the x-axis.

This is indicated by a doubled left-right-arrow-symbol.

The zoom is referring to the current cursor position.

The display of the envelope curve is canceled by pushing the key Enter/Shift right for 3 seconds.

5.10.2 Switching Outputs

5.10.2.1 Operation Cycles – S1...S4

The number of operation cycles per switch output is indicated.

An operation cycle is a complete change of the switch state till back to the start state, thus deactive - active - deactive.

5.10.2.2 Runtime – S1...S4

The runtime per switch output is indicated.

The runtime of each switch output can be reset here separately.

At the pump function runtime, this is especially necessary after a pump exchange, to include the new pump into the runtime dependent activation.

5.10.3 Failures

The device registers multiple of short time or also continuous existing functional failures in type and frequency of occurrence.

- Echo lost - No measurable echo signal available
- OutA1 - overshoot of the analogue output range
Operating mode 4-20mA >> 20,5mA
Operating mode 0-20mA >> 20mA
Operating mode 0-10V >> 10,5V
- OutA1 - undershoot of the analogue output range
Operating mode 4-20mA >> 3,8mA
Operating mode 0-20mA >> -0,4mA – theoretical value
Operating mode 0-10V >> -0,5V – theoretical value
- InD1 - Error pump monitoring
- InD2 - Error pump monitoring
- InD3 - Error pump monitoring
- InD4 - Error pump monitoring

5.10.4 Error Messages

The type of failure, that leads to the device reactions

- Indication on display
- Error signal at analogue output, depending on selected operating mode
- Error function at switching output, depending on settings

can be selected.

The following failures can be selected:

- **Pump monitor**
Default > activated
Only active, if the pump function is activated for switching outputs
- **Output overflow**
Overshoot of the analogue output range OutA1 depending on selected operating mode
 - Operating mode 4-20mA >> 21mA
 - Operating mode 0-20mA >> 21mA
 - Operating mode 0-10V >> 10,5VDefault > activated
- **Output underflow**
Undershoot of the analogue output range OutA1 depending on selected operating mode
 - Operating mode 4-20mA >> 3,8mA
 - Operating mode 0-20mA >> -0,4mA – theoretical value
 - Operating mode 0-10V >> -0,5V – theoretical valueDefault > activated

- **Temperature sensor**

Error of the temperature sensor, which is integrated within the ultrasonic sensor, e.g. short circuit resp. wire break

Default > activated

- **Power loss**

Default > deactivated

5.10.5 Min./Max. Drag Indicator

The drag indicator is used for detection and indication of the minimum and maximum registered measuring values.

The drag indicator can be separately reset by pushing the key Shift right/Enter.

5.10.6 Operating Hours

The operating hours of the device since the last device start-up are detected.

The indication is done in hours.

5.10.7 Operating Hours total

The operating hours of the device since the first device start-up are detected.

The indication is done in hours.

5.10.8 System Starts

The number of the occurred system starts resp. device restarts is registered.

5.10.9 Min./Max. Device Temperature

The minimum and maximum temperature of the device is registered.

5.10.10 Process Temperature

The current process temperature in the area of the sensor is registered.

5.10.11 Min./Max. Process Temperature

The minimum and maximum process temperature in the area of the sensor is registered.

5.10.12 Calibration Date

Indication of the date (format DDMMJJ), the calibration by factory is done.

5.10.13 Serial Number

Indication of the serial number of the device.

5.10.14 Info

Indication of manufacturer data and firmware version

5.11 Data

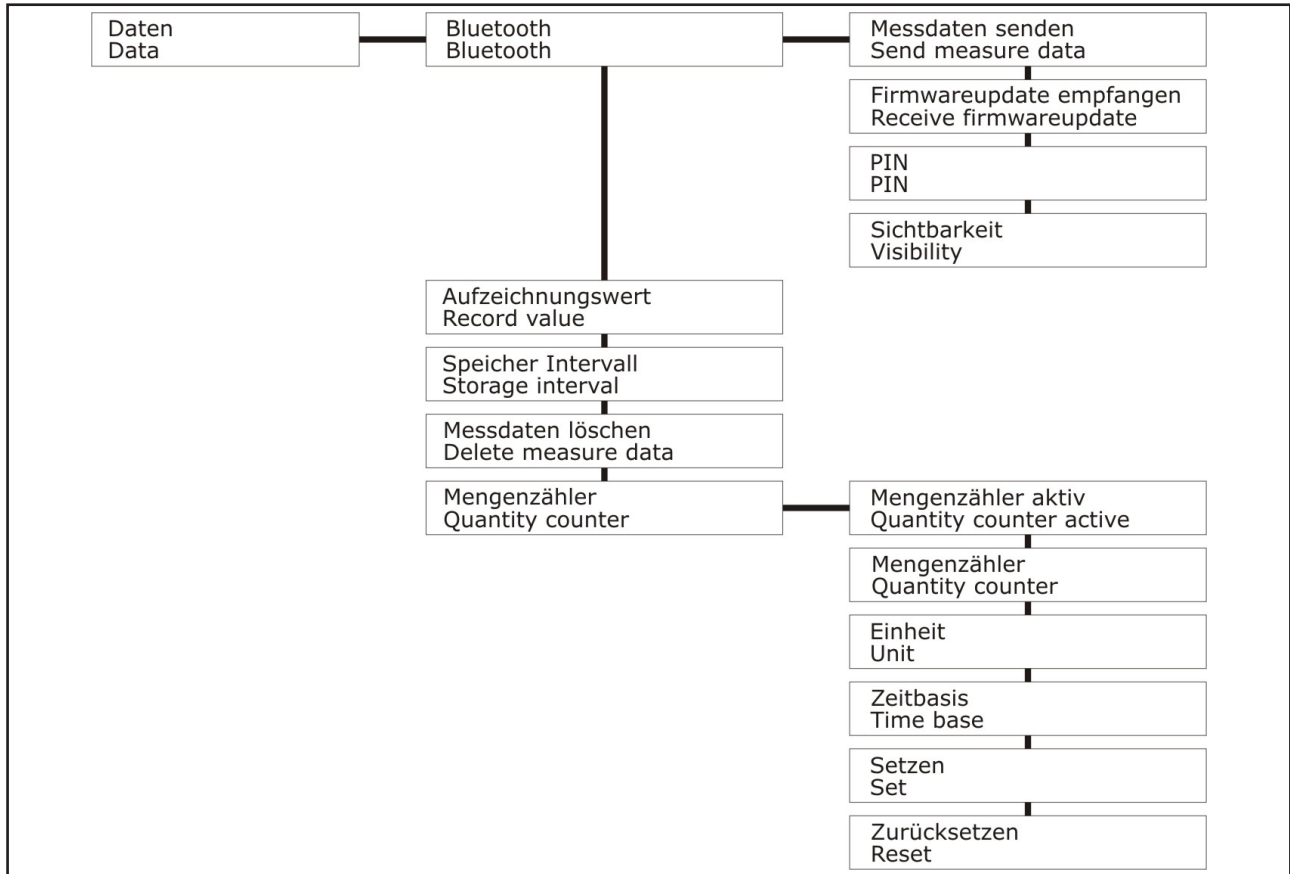

The device is able to record app. a half million measuring values loss-protected. The recording is made in ring memory method, whereas after an overflow the oldest measuring values are overwritten next.

The stored measuring values can be displayed graphically in the indicator type chart or exported as CSV-file per USB- resp. Bluetooth-interface.

By the USB- resp. Bluetooth-interface the download of a firmware file is possible.

The USB menu is automatically displayed after connecting an USB memory device (FAT32).

5.11.1 Bluetooth

For the Bluetooth-communication two authentication methods are available.

- **Unprotected transmission**

No PIN is used

Cause the device does only receive/send files only after selection in the menu, this is the most simple and recommended way of transmission.

If no PIN is used, each communication is uncoded, but the devices must not be connected together.

- **Protected resp. encoded transmission**

A PIN is used.

If a PIN is used, the devices must be connected together for a transmission. The procedure differs depending on the end device.

A PIN must be input and the visibility must be switched to on.

Afterwards the connection can be made at the end device.

In the end device the same PIN must be used, that is input in the device.

After the file transmission the visibility should be switched to off.

Note: For a definite identification of the devices it is recommended to use a Sensor TAG.

5.11.1.1 Send measure data

The recorded measuring values can be transmitted as a CSV-file to a Bluetooth end device. Alternatively all measuring values or only the measuring values from the measuring value cursor (setting in the chart menu) till to the current measuring value can be transmitted. After the selection end devices with Bluetooth-ability are searched and after selection and approval the measuring values are transmitted.

5.11.1.2 Receive firmware update

The internal software of the device (firmware) can be updated by a new firmware, which could include functional improvements, functional extensions, new functions or also customer specific modifications. At the file transmission the safety of the power supply must be ensured. A power fail can lead to a completely irreversible device failure.

5.11.1.3 PIN

For a protected resp. encoded data transmission a PIN must be input. The input range is limited to values from 000000 to 999999.
Default > no PIN allocated

5.11.1.4 Visibility

To transmit a file to the device, it must be visible in the Bluetooth network. Other end devices can identify only visible devices.
Default > Off

5.11.2 Record value

The measuring value can be alternatively recorded as distance, as filling level, percentual, with any desired scaling referring percentual to the measuring range or by displaying the analogue output value.

- Distance
- Level
- Percent
- Scaled
- Analogue output

Default > Distance

5.11.3 Storage interval

The storage interval defines the time interval between two measuring values, that should be stored in the measuring value memory.

The input range is limited to values from 1 to 99999.

Default > 60 s

5.11.4 Delete measure data

All existing stored measuring values in the measuring value memory are erased.

5.11.5 Quantity counter

The quantity counter integrates the calculated measuring values from the display scaling by the time. These values are stored every second.

If the eventually activated impulse output cant output all impulses time conformal due to a too high frequency, all impulses are output afterwards until all accumulated impulses could be output, also if e.g. the flow is already lower or has stopped. Thus the amount of output pulses fits always to the quantity counter. Nevertheless this should be avoided from the first by a correct setting.

- **Quantity counter active**

- Yes
- No

Default > No

- **Quantity counter**

The current quantity counter value, which is calculated at the moment of entering the menu, is displayed.

This value can be actualized by the keys Up or Down.

- **Unit**

- Volume
l / hl / m³ / in³ / gal / ft³
- User defined
Up to 10 characters can be input.
The input range is indefinite.
Default > no text allocated

- **Time base**

- Hours
- Minutes
- Seconds

Default > Hours

- **Set**

The value of the quantity counter can be preset to an arbitrary value.

The input range corresponds with the settings of the display scaling.

Default > 0

- **Reset**

The quantity counter value is reset to 0.

5.12 Start-up procedure

5.12.1 Level measurement

The filling level is calculated by the device due to the distance of the filling material surface to the sensor.

Sub menu Basic Setting

- Commissioning
- Min/Max Adjustment

Sub menu Display

- Indicator value fill level

5.12.1.1 Example

Measurement task

- Distance Sensor - container bottom: 1,8m
- Minimum filling level: 0m >> distance 1,8m - 0m = 1,8m
- Maximum filling level: 1,4m >> distance 1,8m - 1,4m = 0,4m

Settings

- Process commissioning

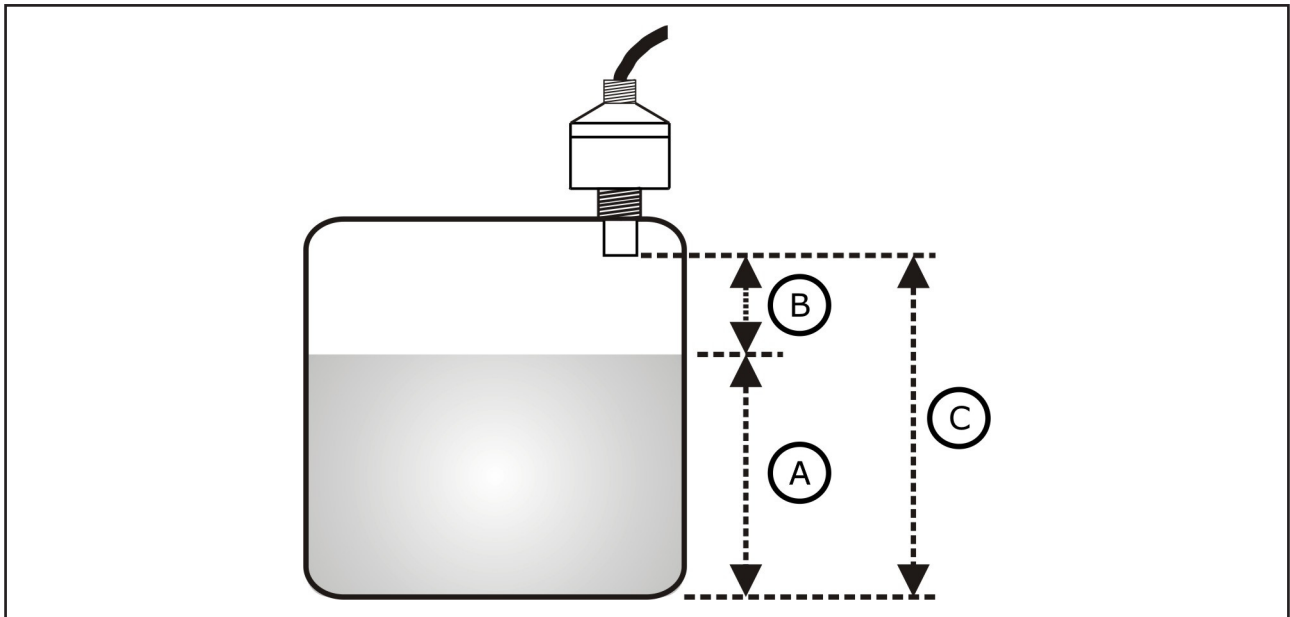

- Min/Max Adjustment: 1,8m = 0% / 0,4m = 100%

A - Filling level

B - Distance sensor – filling material surface

C - Distance sensor – container bottom

5.12.2 Volume measurement

For the indication of the tank volume a display scaling can be made.
If a nonlinear tank style is used, a linearization must be set.
Predefined linearization curves for some tank styles are available.

Sub menu Basic Setting

- Commissioning
- Min/Max Adjustment
- Linearization

Sub menu Display

- Indicator value Scaled
- Unit
- Scaling - ration percent / tank volume

5.12.2.1 Example

Measurement task

- Distance Sensor - container bottom: 1,8m
- Container: Cylinder - linear volume
- Minimum filling level: 0,2m >> distance $1,8\text{m} - 0,2\text{m} = 1,6\text{m}$
- Maximum filling level: 1,2m >> distance $1,8\text{m} - 1,2\text{m} = 0,6\text{m}$
- Minimum volume: 0 liter
- Maximum volume: 2000 liter

Settings

- Process commissioning
- Min/Max Adjustment: $1,6\text{m} = 0\%$ / $0,6\text{m} = 100\%$
- Display Indicator value: scaled
- Display Unit: l
- Display Scaling: $0\% = 0\text{ l}$ / $100\% = 2000\text{ l}$
- Linearization: Linear

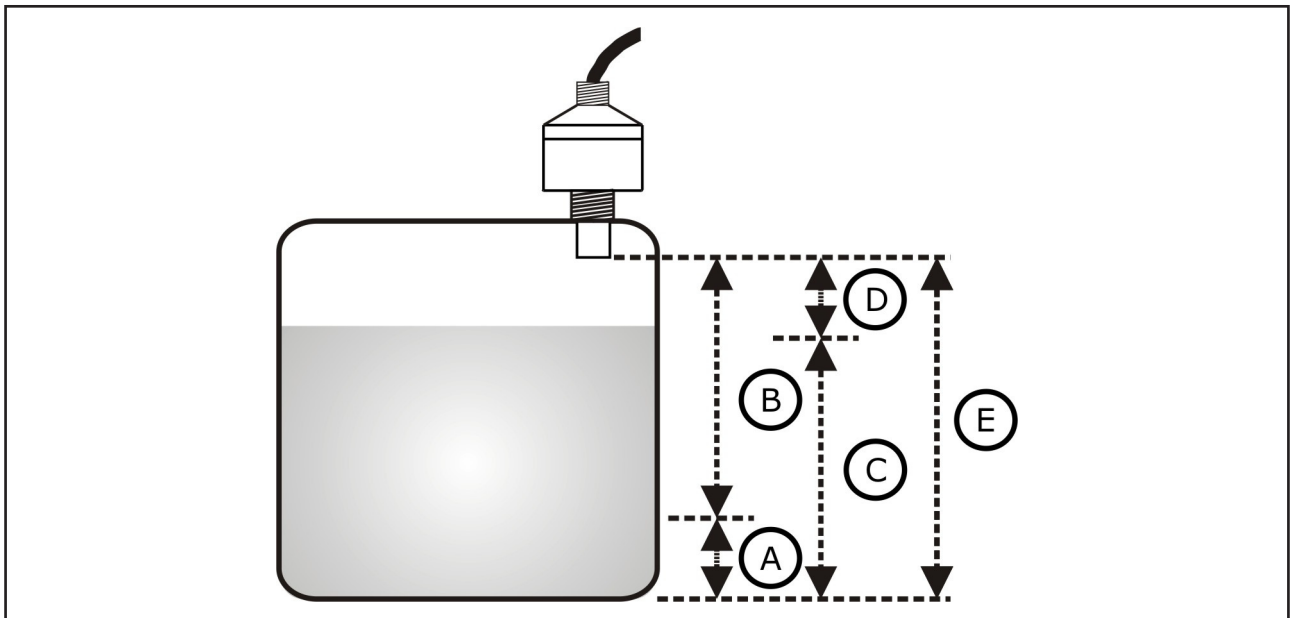

- A - Minimum volume
- B - Distance at minimum volume
- C - Maximum volume
- D - Distance at maximum volume
- E - Distance sensor - container bottom

5.12.3 Flow measurement

For the indication of the flow amount a display scaling can be made.
If a nonlinear flow opening style is used, a linearization must be set.
Predefined linearization curves for some flow opening styles are available.

Sub menu Basic Setting

- Commissioning
- Min/Max Adjustment
- Linearization

Sub menu Display

- Indicator value scaled
- Unit
- Scaling - ration percent / flow amount

5.12.3.1 Example

Measuring task

- Style: Triangle weir
- Level minimum flow: 0,95m at 0 l/s
- Level maximum flow: 0,45m at 69 l/s

Settings

- Process commissioning
- Min/Max Adjustment: 0,95m = 0% / 0,45m = 100%
- Limit min/max: active
- Display Indicator value: scaled
- Display Unit: l/s
- Display Scaling: 0% = 0 l/s / 100% = 69l/s
- Linearization: triangular weir

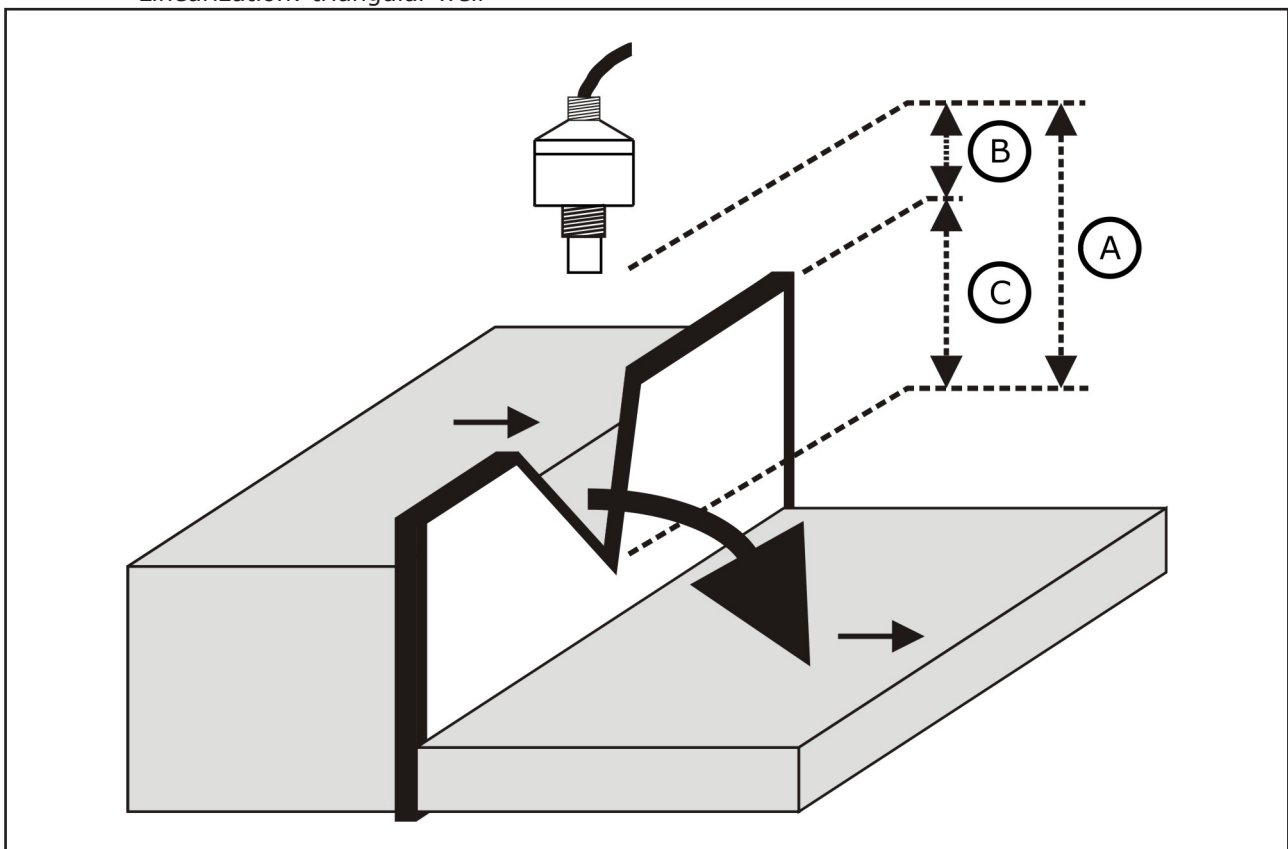

- A - Distance at minimum flow
- B - Distance at minimum flow
- C - Maximum water level Hmax

5.13 Software history

Version	Date	Modifications
1.0	09/2016	Original version

6 Service

6.1 Maintenance

The device is free of maintenance.

6.2 Dismounting

Attention – Risk of injury!

Switch the device from the mains at all terminals before dismounting it.
During dismounting there is a risk of electric shock.

6.3 Repair

A repair may only be carried out by the manufacturer.

If the device is sent back for repair, the following information's must be enclosed:

- An exact description of the application.
- A short description of the occurred error.

6.4 Return

Before returning the device, the following measures must be performed:

- All adhesive product residues must be removed. This is especially important, if the product is unhealthy, e.g. caustic, toxic, carcinogenic, radioactive etc.
- A returning must be refrained, if it is not possible by 100% to remove the unhealthy product completely, because e.g. it is penetrate into cracks or is diffused through plastic.

6.5 Disposal

Dispose of instrument components and packaging materials in an environmentally compatible way and in accordance with the country-specific waste disposal regulations.

7 Technical Data

Reference conditions	EN/IEC 60770-1, EN/IEC 61003-1	
	Environmental temperature	25°C
	Environmental air pressure	860..1060kPa
	Air humidity	45...75% r.h.
	Warm-up time t_{on}	240s
	Supply voltage U_s	230V _{AC} ±10%, 50Hz 24V _{DC} ±0,1V

7.1 Auxiliary power supply

7.1.1 Electronic type A / B / D

Supply voltage U_s	18..36V _{DC} , reverse polarity protected	
Residual ripple U_{pp}	$\leq 2V_{pp} / U_{Smin} \leq U_s \leq U_{Smax}$	
Power consumption P_{in}	$\leq 5W$	
Isolation voltage	Auxiliary power	1kV AC
	Relay outputs	3kV AC
	Input analogue/digital – output analogue	500V DC

7.1.2 Electronic type S / T / U

Supply voltage U_s	186..253V _{AC}	
Power consumption P_{in}	$\leq 20VA$	
Isolation voltage	Auxiliary power	3kV AC
	Relay outputs	3kV AC
	Input analogue/digital – output analogue	500V DC

7.2 Input

7.2.1 Signal ultrasonic sensor – InA1

Measuring range distance (consider blocking distance BD of the connected sensor!)	Measuring range	Operating frequency f_{US}	Pulse rate t_p (measure cycle time)
	0...2m	125kHz	5Hz (200ms) 2,5Hz (400ms) 1,25Hz (800ms)
	0...5m	75kHz	2,5Hz (400ms) 1,25Hz (800ms) 0,625Hz (1600ms)
	0...8m	50kHz	1,667Hz (500ms) 0,833Hz (1000ms) 0,417Hz (2000ms)
	0...15m	41kHz	1,667Hz (500ms) 0,833Hz (1000ms) 0,417Hz (2000ms)
	0...25m	30kHz	1,667Hz (500ms) 0,833Hz (1000ms) 0,417Hz (2000ms)
Meas. range temperature T_p	-50°C...+100°C		

7.2.2 Digital input – InD1/2/3/4

Operating range U_{in} (IEC 61131-2)	<i>Signal low – logic 0</i> -3 ... 5V
	<i>Signal high – logic 1</i> -12 ... 30V ($U_{in,max} \leq 36V$)
Internal resistor R_e	$\geq 300k\Omega$

7.3 Output

7.3.1 Signal current – OutA1

Operating range I_{Out}	<i>Signal 0...20mA</i> 0mA ... 20,5mA/22mA
	<i>Signal 4...20mA</i> 3,6/3,8mA ... 20,5mA/22mA
Resolution	14 Bit / $\leq 1\mu A$
Output voltage U_{max}	$\leq 16V$
Permitted load R_L	$\leq 700\Omega$ ($I_{Out} = 20mA$) $\leq 636\Omega$ ($I_{Out} = 22mA$)
Step response time t_{90}	$\leq 35ms$ ($t_d = 0s$)
Start-up time t_{on}	$\leq 1s$

7.3.2 Signal voltage – OutA1

Operating range U_{Out}	<i>Signal 0...10V</i> 0 ... 10,5V, max. 11V
Resolution	14 Bit / $\leq 1mV$
Output current I_{max}	$\leq 35mA$, current limited/short circuit proof
Permitted load R_L	$\geq 400\Omega$ ($U_{Out} = 10V$) $\geq 440\Omega$ ($U_{Out} = 11V$)
Step response time t_{90}	$\leq 35ms$ ($t_d = 0s$ / $R_L = 10k\Omega$)
Start-up time t_{on}	$\leq 1s$

7.3.3 Switch output – S1/S2/S3/S4

Function	Potential-free changeover contact
Resolution	1 digit
Maximum switching power AC	253V _{AC} – 6A 1500VA (ohmic load) / 300VA ($\cos \varphi \geq 0,7$)
Maximum switching power DC	30V _{DC} – 6A – 180W 110V _{DC} – 0,2A – 22W 220V _{DC} – 0,12A – 26,4W
Minimum switching load	0,5W (12V / 10mA)
Response time $t_{on/off}$	$\leq 20ms$ ($t_d = 0s$)
Start-up time t_{on}	$\leq 1s$
Impulse time t_p (S1)	$\geq 0,1s$
Switch cycles	$\geq 10.000.000$ (load-free) ≥ 60.000 (max. load)

7.4 Measuring accuracy

7.4.1 Input ultrasonic sensor – InA1

Characteristic deviation ³⁾	$\leq \pm 2mm$ or $\pm 0,2\%$ set measuring range ¹⁴⁾ ($t_d \geq 5s$)
Temperature deviation	$\leq \pm 0,1\%$ FS ²⁾ / 10K
Long term deviation	$\leq \pm 0,05\%$ FS ²⁾ / year

7.4.2 Output U/I – OutA1

Characteristic deviation ³⁾	$\leq \pm 0,05\%$ FS ²⁾
Temperature deviation	$\leq \pm 0,1\%$ FS ²⁾ / 10K
Long term deviation	$\leq \pm 0,05\%$ FS ²⁾ / year

²⁾ Referring to nominal measuring span resp. full scale (FS)

³⁾ Nonlinearity + Hysteresis + Reproducibility

¹⁴⁾ whichever is greater

7.5 Interface

7.5.1 USB

Version	2.0 Full Speed
Function	Host
Output voltage	5V \pm 5%, \leq 100mA
Jack socket	USB 2.0-A

7.5.2 Bluetooth

Version	Bluetooth 2.1 + EDR
Specification	Class 2
Transmit power	\leq 2,5mW / 4dBm
Range	\leq 10m

7.6 Data memory

Memory size	4MB / \geq 500.000 measuring values
Memory system	Ring memory
Memory rate	1...99999s

7.7 Clock

Cycle accuracy	$\leq \pm 1$ minute / month
Battery run time	\geq 10 years
Hold-up time battery-free system	\geq 1 minute

7.8 Environmental conditions

Environmental temperature	-20°C...+60°C <i>Limitation</i> Backlight LCD >85% >> -20°C...+50°C
Protection	<i>Field enclosure type F / DIN-rail enclosure type P</i> IP65 (EN/IEC 60529) <i>Front panel enclosure type M</i> Front side IP54 (EN/IEC 60529) Rear side IP20 (EN/IEC 60529) <i>Front panel enclosure type M</i> <i>Electronic extras type 2 – increased protection class</i> Front side IP65 (EN/IEC 60529)
Climatic classification	<i>Field enclosure type F / DIN-rail enclosure type P</i> 4K4H (EN/IEC 60721-3-4) <i>Front panel enclosure type M</i> 3K3 (EN/IEC 60721-3-3)
Shock classification	3g [2...150Hz] (EN/IEC 60068-2-27)
Vibration classification	3g [2...150Hz] (EN/IEC 60068-2-6)
EM compatibility	Operation device class B / Industrial range (EN/IEC 61326)
Weight	<i>Field enclosure type F / DIN-rail enclosure type P</i> 0,8kg <i>Front panel enclosure type M</i> 0,4kg

7.9 Materials

Terminal enclosure	<i>Field enclosure type F / DIN-rail enclosure type P</i> PC / PES / CrNi-steel / PA / CR-NBR
	<i>Front panel enclosure type M</i> PPE / PES / steel zinc-coated / CrNi-steel / PA / NBR-EPDM

8 Dimension drawings

8.1 Terminal enclosure

8.1.1 Field enclosure – Type F

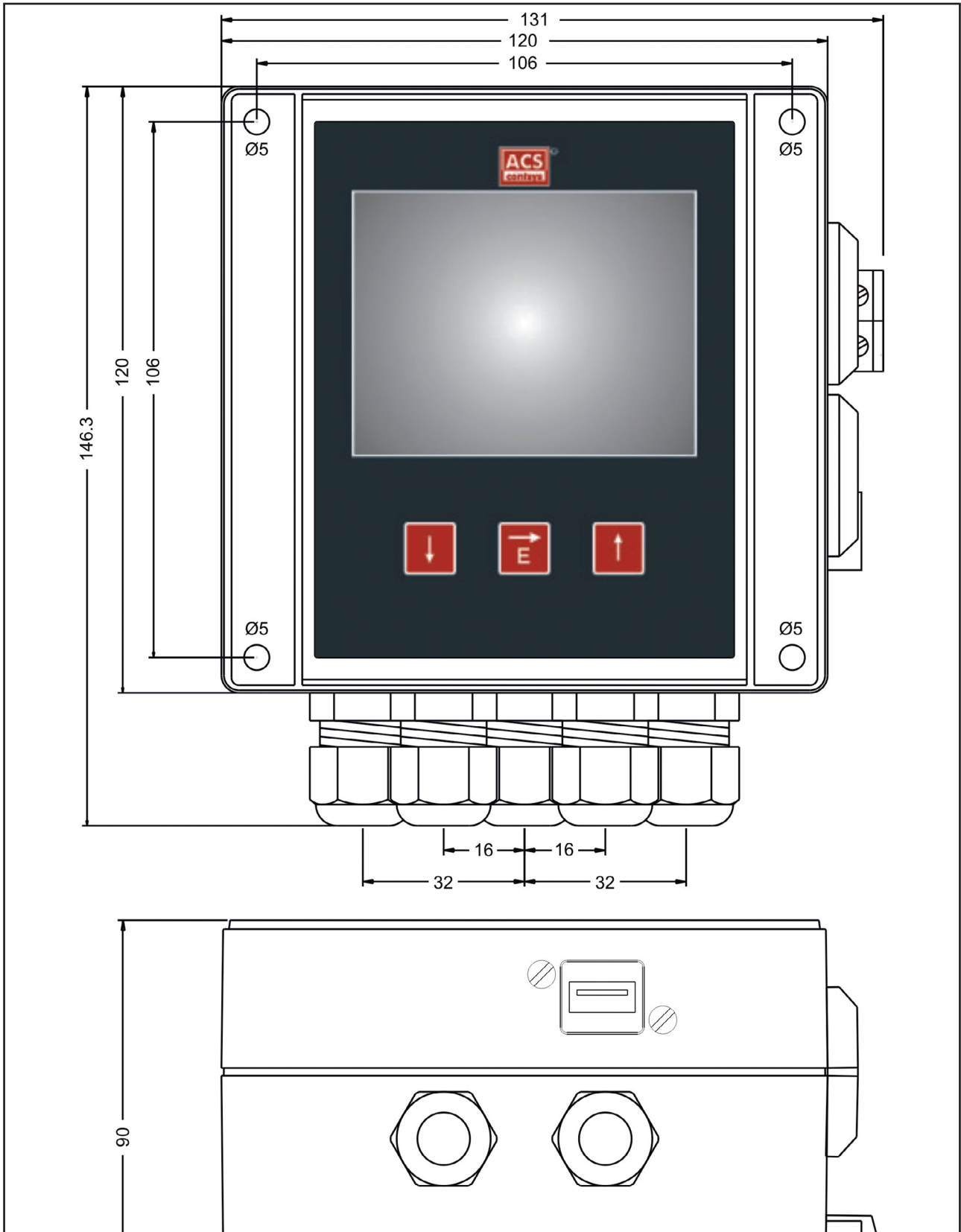

8.1.2 DIN-rail enclosure – Type P

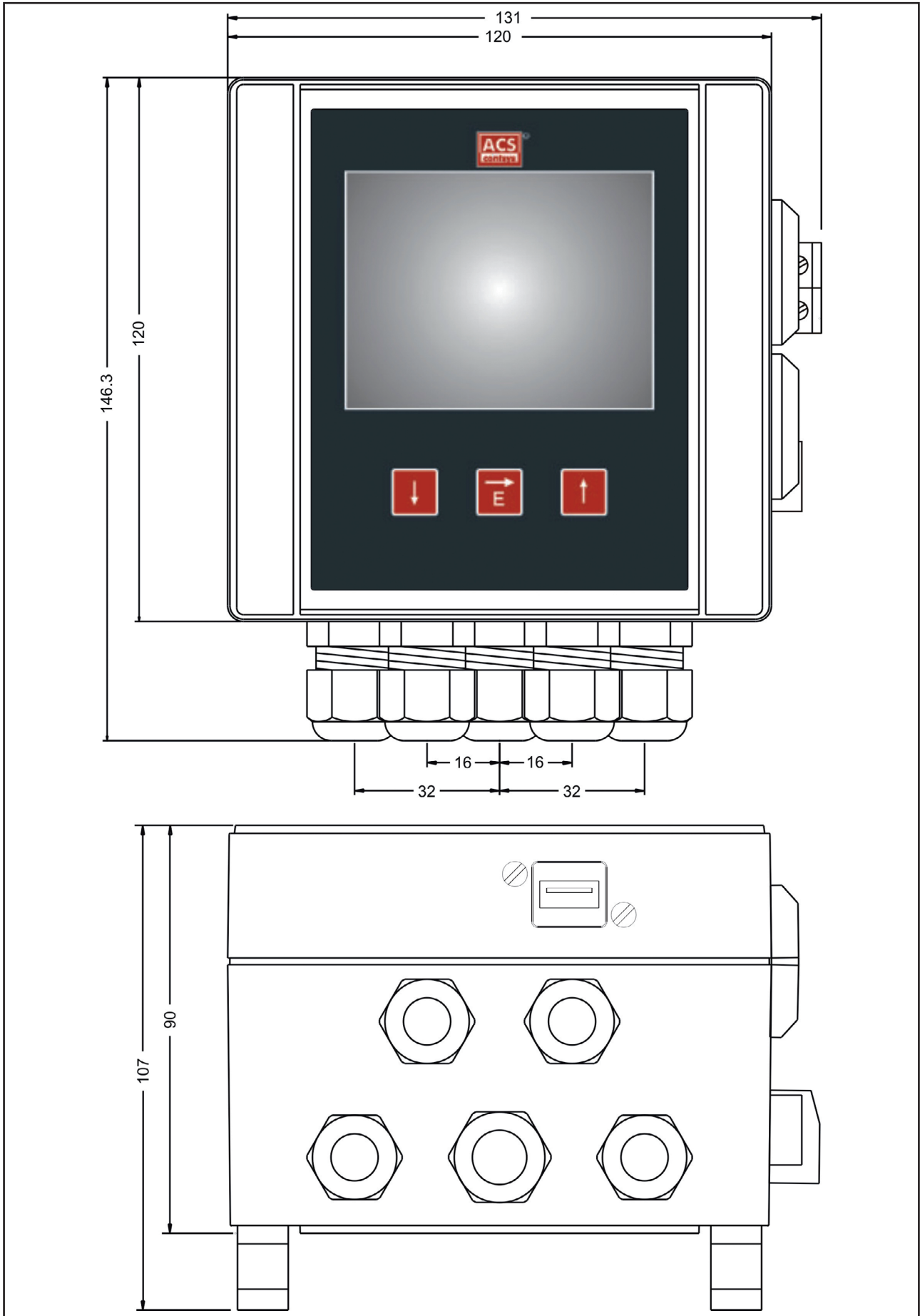

8.1.3 Front panel enclosure – Type M

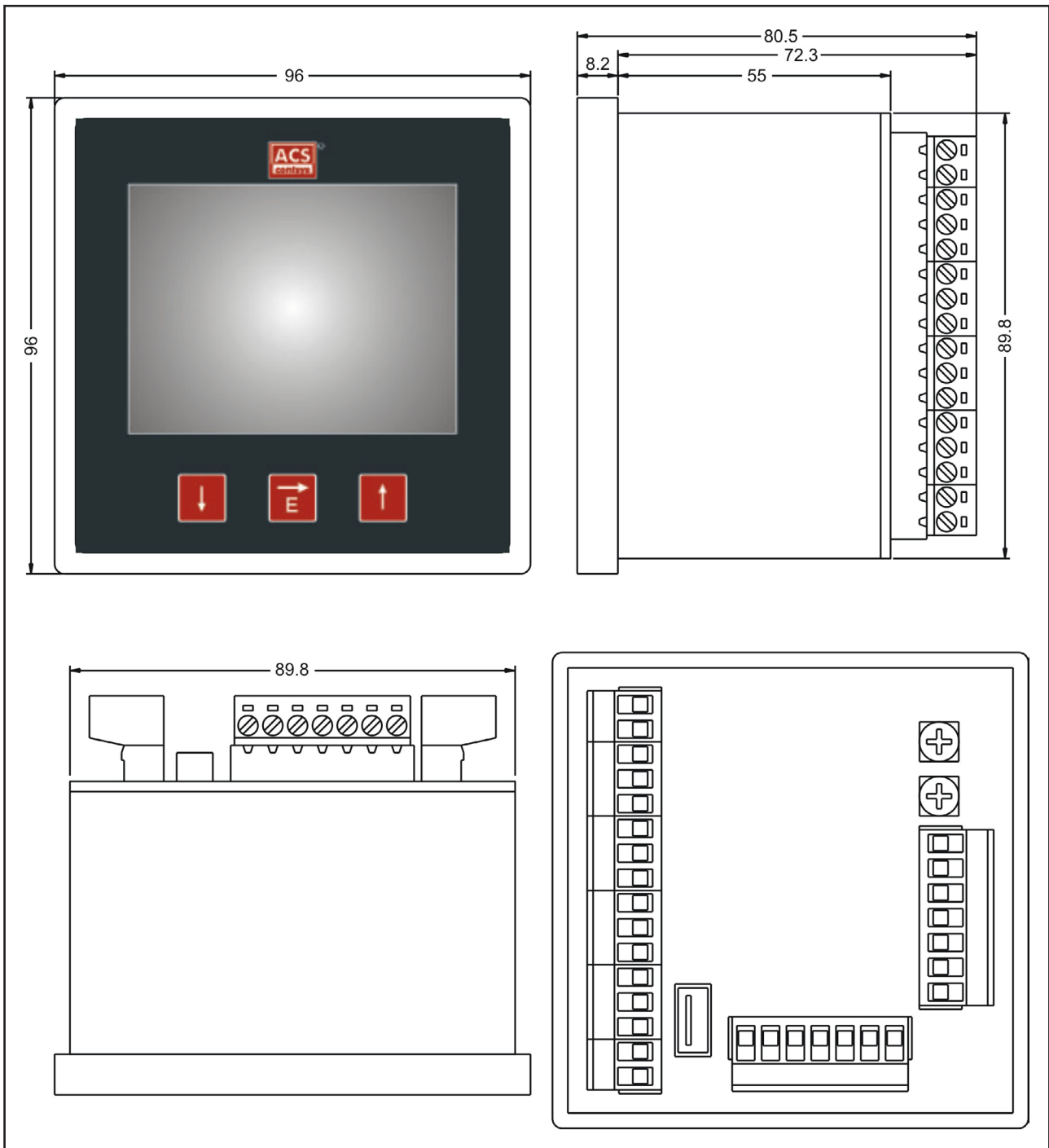

At version certification type X – ATEX the enclosure depth increases by 27mm due to the necessary cable housing.

9 Ordering information

9.1 Order code

USF2	Type Standard
	Approval
0	Standard
X	ATEX II (1) G [Ex ia Ga] IIC / ATEX II (1) D [Ex ia Da] IIIC
	Enclosure type
F	Field enclosure
P	DIN-rail enclosure
M	Front panel enclosure
	Electronic – supply / output
A	18...36V DC / 1x 0/4...20mA - 0...10V
B	18...36V DC / 1x 0/4...20mA - 0...10V, 2x relay, 2x digital input
D	18...36V DC / 1x 0/4...20mA - 0...10V, 4x relay, 4x digital input
S	186...253V AC / 1x 0/4...20mA - 0...10V
T	186...253V AC / 1x 0/4...20mA - 0...10V, 2x relay, 2x digital input
U	186...253V AC / 1x 0/4...20mA - 0...10V, 4x relay, 4x digital input
	Electronic - function
0	USB-Interface
1	USB+Bluetooth-Interface
2	USB-Interface / Data logger with time stamp, battery powered
3	USB+Bluetooth-Interface / Data logger with time stamp, battery powered
Y	others
	Electronic - extras
0	Standard
1	USB device jack – Enclosure type F / P
2	Increased protection class IP65 – Enclosure type M
	S Standard

Sonicont USF2 S

Installation material and connection cable are not enclosed in contents of delivery.

9.2 Additional options

For the device additional options are available.

The respective abbreviation subsequently follows the order code.

- ML Measurement point designation / TAG – Laser marking (type F/P) / sticker (type M)
- KL Customer label on device – Laser marking (enclosure type F/P) / sticker (type M)
- TN Type label neutral
- KF Configuration / Preset

9.3 Accessories

Accessories are not content of delivery of the device and must be ordered separately.

9.3.1 Interface USB

- Front panel installation socket USB 2.0-A (IP68) / cable 0,5m / plug USB 2.0-A

ACS-CONTROL-SYSTEM
knowledge and systems

Your partner for measuring technology and automation



ACS-CONTROL-SYSTEM GmbH
Lauterbachstr. 57
D- 84307 Eggenfelden

Tel.: +49 (0) 8721/ 9668-0
Fax: +49 (0) 8721/ 9668-30

info@acs-controlsystem.de
www.acs-controlsystem.de